

# Howard - McCray

## 34N SERIES DOUBLE DUTY DELI



MODEL NO.	DESCRIPTION	LENGTH	DEPTH	HEIGHT	VOLTAGE	AMPS	HP/BTUS	POWER CORD	EST. SHIP WEIGHT
SC-CDS34N-4-LED	Self Contained	48"	37.50"***	55"	115	12.0	1/4	5-15P	530
SC-CDS34N-6-LED	Self Contained	72"	34.25"	55"	115	12.0	1/3	5-15P	741
SC-CDS34N-8-LED	Self Contained	96"	34.25"	55"	115	16.0	1/2	5-20P	897
SC-CDS34N-10-LED	Self Contained	120"	34.25"	55"	115	13.8	1/2	NO	1150
SC-CDS34N-12-LED	Self Contained	144"	34.25"	55"	115	17.4	3/4	NO	1414
R-CDS34N-4-LED	Remote	48"	34.25"	55"	115	0.8	1400	NO	497
R-CDS34N-6-LED	Remote	72"	34.25"	55"	115	1.3	2100	NO	693
R-CDS34N-8-LED	Remote	96"	34.25"	55"	115	1.6	2800	NO	832
R-CDS34N-10-LED	Remote	120"	34.25"	55"	115	2.4	3500	NO	1089
R-CDS34N-12-LED	Remote	144"	34.25"	55"	115	2.4	4200	NO	1359

MODEL NUMBER PREFIX - SC = Self Contained R = Remote  
 MODEL NUMBER SUFFIX - W = White B = Black S = Stainless Steel LED = LED lighting  
 • Cases are designed to operate at 75 degrees Fahrenheit and 55% relative humidity  
 • Cases are equipped with drains; check your local building codes for connection requirements.  
 • Specification subject to change without notice  
 IF COLORS ARE MIXED AN ADDITIONAL CHARGE WILL APPLY



**34N SERIES DOUBLE DUTY DELI****STANDARD SPECIFICATIONS AND OPTIONAL FEATURES****CONSTRUCTION**

- UL Classified to ANSI/NSF 7
- Foamed in place CFC free foam
- Thermal insulated front glass 28"H
- Heavy gauge steel super structure
- Bottom storage
- Drain is included for cleaning

**INTERIOR**

- White, black or stainless steel ends
- Stainless steel heavy gauge mezzanine shelf
- White aluminum floor (bottom storage area)
- Air insulated baffle (prevents moisture from dripping into display area)

**EXTERIOR**

- Double pane rear removable doors
- Newly designed rear compression door jamb
- Removable front grille allows for cleaning
- Removable rear grille for easy servicing
- GFI protected outlet mounted rear
- Removable rear top glass doors
- Removable rear bottom doors
- Rear exterior mounted switch
- Rear mounted electronic control (thermostat)
- 1" Front Bumper

**FINISHES**

- Thermal formed doors and door tracks
- White, black or stainless steel front and ends
- Stainless steel mirror trim
- Stainless steel heavy gauge top - 23.3" W
- White, black or stainless steel exterior rear

**LIGHTING**

- LED lighting
- 2 rows of lighting at top of unit

**ELECTRICAL REQUIREMENTS**

- 115V 4', 6' & 8' with power cord
- UL/CUL listed
- 115V-15AMP general purpose receptacle (wired separately) 10' & 12' only

**REFRIGERATION**

- CopeVap system (eliminates need for condensate pan)
- Full length gravity coil located at inside top of unit and in bottom day storage area
- Self contained unit
- Automatic defrost electronically controlled
- Remotes available

**OPTIONS**

- Scale stand 8'
- Paper cutter 8'
- Stainless steel, laminate, or paint
- Mirrored doors
- Extra stainless steel mezzanine shelf
- Drop work shelf
- 1" Special color front bumper
- Door locks
- Digital thermometer
- Coated coils
- Lit shelves up to two (2) rows

**IMPORTANT NOTE:**

**ALL REFRIGERATED CASES ARE DESIGNED TO OPERATE IN AN ENVIRONMENT OF 75 DEGREES AND 55% RELATIVE HUMIDITY.**

**PRODUCT MUST BE COOLED BEFORE BEING DISPLAYED WITHIN THE CASE.**

**DRAIN IS REQUIRED**

**34N SERIES DOUBLE DUTY DELI**

**TECHNICAL DATA**

Model No.	SC R	SC-CDS34N-4-LED R-CDS34N-4-LED	SC-CDS34N-6-LED R-CDS34N-6-LED	SC-CDS34N-8-LED R-CDS34N-8-LED	SC-CDS34N-10-LED R-CDS34N-10-LED	SC-CDS34N-12-LED R-CDS34N-12-LED
Length		48"	72"	96"	120"	144"
Height		55"	55"	55"	55"	55"
Depth		34.25"	34.25"	34.25"	34.25"	34.25"
Depth with bottom door (Dimensions are +/- 1/4")	SC	37.5"	34.25"	34.25"	34.25"	34.25"
Operating temperature		36°F to 40°F	36°F to 40°F	36°F to 40°F	36°F to 40°F	36°F to 40°F
Compressor size HP	SC	1/4	1/3	1/2	1/2	3/4
Defrost per day (24 hours)		Electronic controlled 1 per day	Electronic controlled 1 per day	Electronic controlled 1 per day	Electronic controlled 1 per day	Electronic controlled 1 per day
BTU's at +20°F Evap. Temp.	R	1400	2100	2800	3500	4200
Voltage		115	115	115	115	115
Amperage unit only		12.0	12.0	16.0	13.8	17.4
Cord and plug		Yes	Yes	Yes	No	No
Exterior color		White/Black	White/Black	White/Black	White/Black	White/Black
Interior color		White	White	White	White	White
Inside end panels		White	White	White	White	White
Floors		White	White	White	White	White
# of top doors		2	2	4	4	4
Door size		23.56" x 18.56"	23.56" x 29.3"	23.56" x 19.56"	23.56" x 29.3"	23.56" x 19.56"
# of bottom doors	SC	1 external	2 sliding	2 sliding	2 sliding	2 sliding
Bottom door size		14" x 18.56"	14" x 19.56"	14" x 40.3"	14" x 29.3"	14" x 23.8"
# of coils		2	2	2	2	2
Bottom storage		Yes	Yes	Yes	Yes	Yes
Front glass		28" x 43.0"	28" x 67.0"	28" x 91.0"	28" x 115"	28" x 139"
# of main deck shelves		2	3	4	5	6
Main deck size		(1) 30" x 18" (1) 30" x 23.875"	(1) 30" x 18" (2) 30" x 23.875"	(1) 30" x 18" (3) 30" x 23.875"	(1) 30" x 18" (4) 30" x 23.875"	(1) 30" x 18" (5) 30" x 23.875"
Floor Racks		(1) 23.625" x 22"	(2) 23.625" x 22"	(3) 23.625" x 22"	(4) 23.625" x 22"	(5) 23.625" x 22"
Cubic capacity		25.30	40.0	55.9	72.8	87.8
Mezzanine shelf		43.25" x 12.00"	66.50" x 12.00"	(2) 45.875" x 12.00"	(2) 57.25" x 12.00"	(2) 69.25" x 12.00"
<b>Shipping Info</b>						
Height		63"	63"	63"	63"	63"
Depth		44"	44"	44"	44"	44"
Length		61"	87"	109"	133"	157"
Gross weight SC/R		530/497	741/693	897/832	1150/1089	1414/1359

**(ALL WHITE OR ALL BLACK, NO EXTRA CHARGE—IF COLORS ARE MIXED AN ADDITIONAL CHARGE WILL APPLY)**

Prefix	Suffix
SC = Self Contained	B = Black
R = Remote	W = White
	SS = Stainless Steel
	LS = Lit Shelving
	LED = LED lighting

- Cases are designed to operate at 75 degrees Fahrenheit and 55% relative humidity
- Cases are equipped with drains; check your local building codes for connection requirements.
- Specification subject to change without notice

34N SERIES DOUBLE DUTY RED MEAT

DRAWINGS • SIDE VIEW • PLAN VIEW

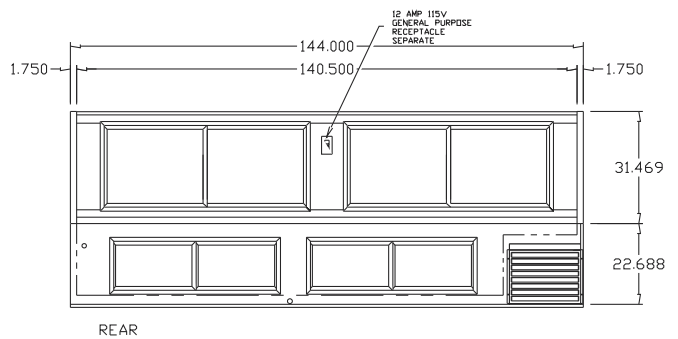
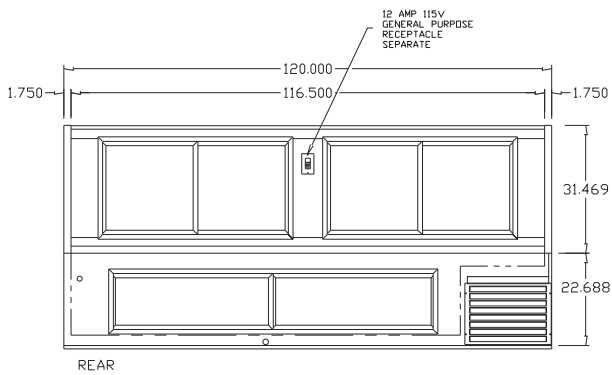
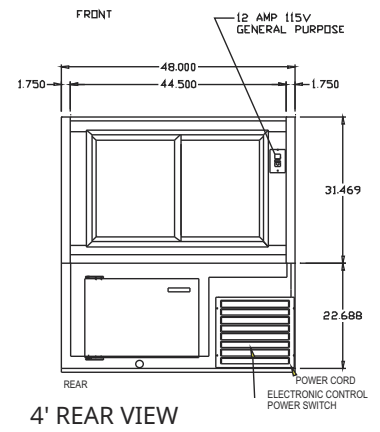
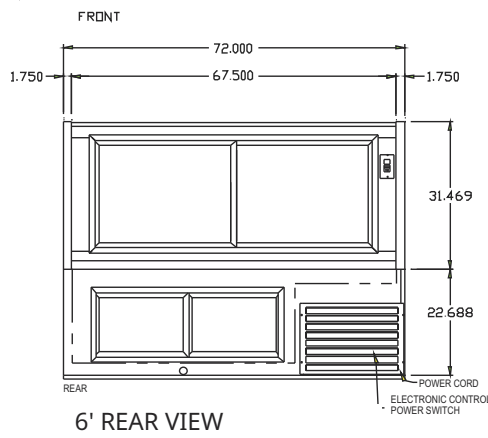
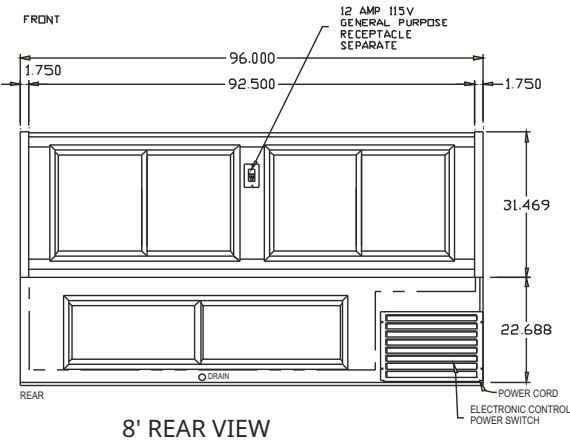
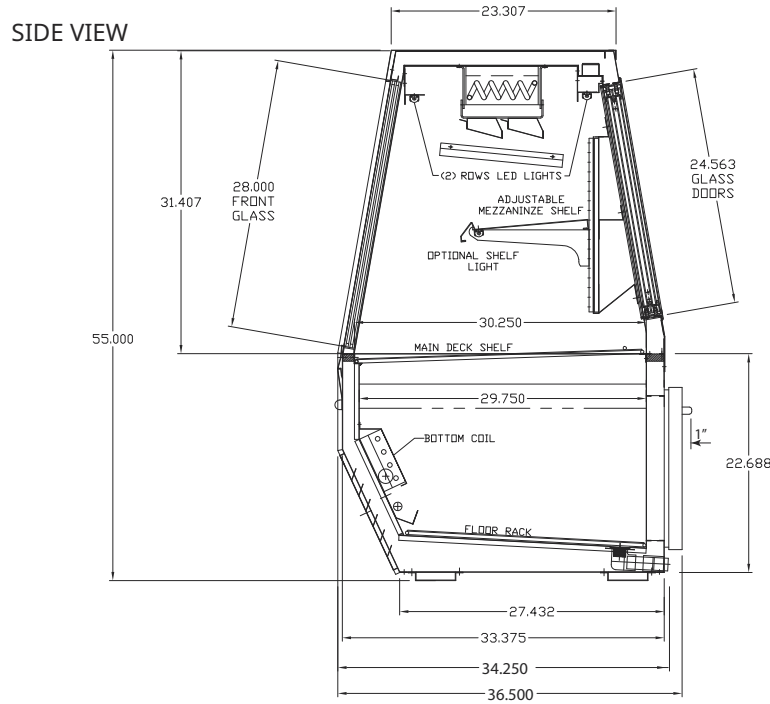

10' REAR VIEW

12' REAR VIEW