

Item: _____	Model #: _____
Quantity (Qty): _____	Project: _____

GAS CONVECTION OVEN - BAKERY DEPTH

CO200G



CO200G

100% manufactured from raw materials to provide the best cooking experience, a high standard of quality, and the highest durability in its class to meet the needs of a commercial kitchen.

STANDARD FEATURES

- One year parts warranty.
- 50,000 BTU burner.
- Stainless steel front, sides and top panels.
- Sturdy, detachable doors with turnbuckle assembly.
- Stainless steel doors with double pane window.
- 4" (100mm) locking swivel casters.
- 1020 steel chassis interlocking frame.
- Porcelain-enameled oven cavity with removable tray supports designed for hassle-free cleaning.
- Oven cavity with coved corners for better heat circulation.
- Interior halogen lights.
- Structure of racks \varnothing 1/4".
- Five chrome-plated racks, twelve rack positions with a minimum of 1 1/2" (40 mm) spacing.
- Safety system that turns off the fan when opening the oven doors.
- Electronic spark ignition system.
- High output atmospheric burner system.
- Solid state thermostat with temperature control range of 150 °F (65°C) to 500°F (260°C).
- Forced air system responsible for evenly baking food and maximizing efficiency for energy savings.
- 3/4 horsepower blower motor with reverse rotation.
- Manual gas service cut-off switch located on the front of the control panel.
- Two auxiliary cooking features: Hold and Pulse.
- Two speed fan motor: High and Low.

OPTIONS & ACCESSORIES

- 6" (152 mm) legs.
- Additional oven rack.

AREA FOR CONSULTANT / CONTRACTOR:

GAS CONVECTION OVEN - BAKERY DEPTH

CO200G

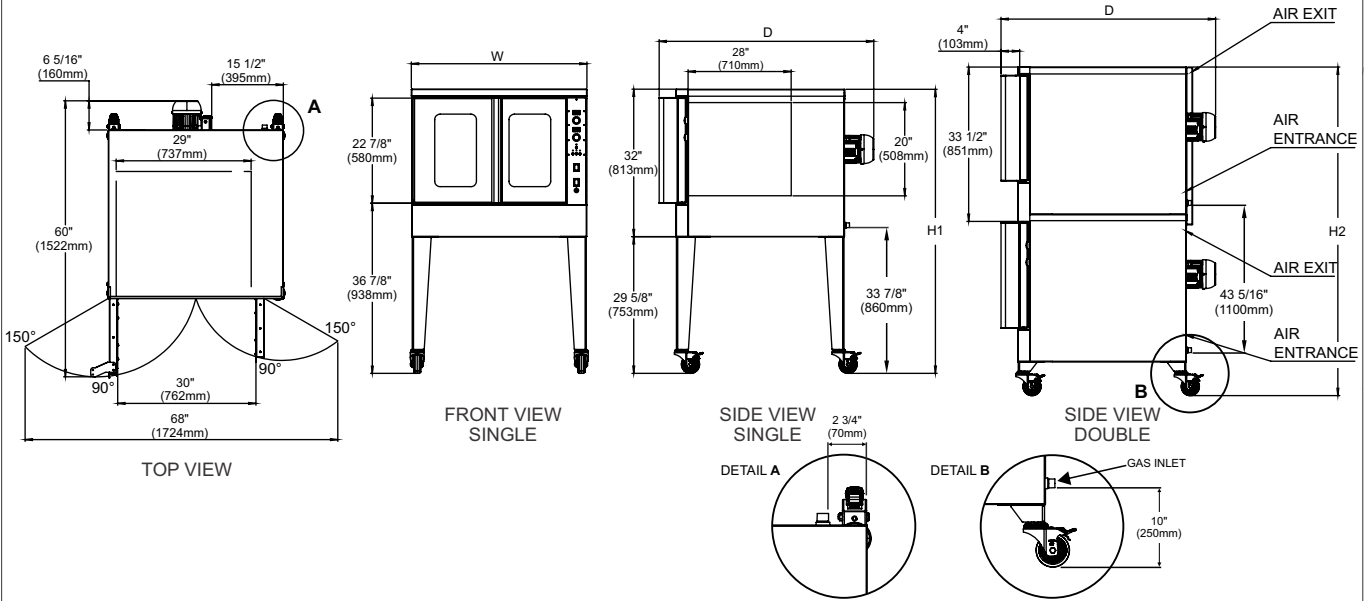

Model	Exterior Product Dimensions & Weight					Shipping Crate Dimensions & Weight				Oven Cavity (per deck)		
	Width (W)	Depth (D)	Height (H1)	Height (H2)	Weight	Width	Depth	Height	Weight	Width	Depth	Height
CO200G - BD Base deck			61 5/8"		503 lbs (228 kg)		55"	39 3/8"	609 lbs (276 kg)			
CO200G - SD Single deck	38" (965 mm)	49 5/8" (1260 mm)	(1566 mm)			43 5/16" (1100 mm)	(1396 mm)	(1000 mm)		29" (737 mm)	28" (710 mm)	20" (508 mm)
CO200G - DD Double deck				71 3/8" (1812 mm)	935 lbs (424 kg)		52 1/4" (1326 mm)	77 9/16" (1970 mm)	992 lbs (450 kg)			

UTILITY INFORMATION

GAS SUPPLY					
Models	Burners	Propane BTU/h	Natural BTU/h	Manifold Pressure	
				Propane Gas	Natural Gas
CO200G - BD/SD	4	50,000	50,000	10" W.C	4" W.C
CO200G - DD	8	100,000	100,000	10" W.C	4" W.C

SPECIFICATIONS

- 3/4" NPT rear gas connection and pressure regulator for both natural gas and propane.
- Check the altitude specifications above 2,000 ft.
- Specify the type of gas when ordering.

ELECTRICAL CHARACTERISTICS							
Model	Total kW Connection	1 Phase					
		120 V		208 V		240 V	
		X	Y	X	Y	X	Y
CO200G (per deck)	0,72	4.8	4.8	4.5	4.5	4.5	4.5

- 1 phase, 2-wire with ground, 60 Hz, 5 A, 3/4 HP, 2 speed motor, 1125 and 1725 RPM

INSTALLATION INSTRUCTIONS

A pressure regulator sized for this unit is necessary. The gas line connecting to the oven must be 3/4" or larger. If flexible connectors are used, the inside diameter must be 3/4" or larger. An adequate ventilation system is required for commercial cooking equipment. Information may be obtained by writing to the National Fire Protection Association, 1 Batterymarch Park, Quincy, MA 02269, www.NFPA.org. When writing, refer to NFPA No. 96.4. These units are manufactured for installation in accordance with ANSZ223.1A (latest edition), National Fuel Gas Code. Copies may be obtained from The American Gas Association, 400 N Capitol St. NW, Washington, DC 20001, www.AGA.org.

Venancio continuously improves the design of its products, therefore reserves the right to change specifications at any time without prior notice. Such revisions do not entitle the buyer to corresponding changes, improvements, additions or replacements for previously purchased equipment.