

PORTABLE BAR

Compliant with
NSF/ANSI Standard 2



Item Numbers

DXPPB5TBKES
DXPPB5TBKMS
DXPCUVWROC
DXPCUVWTIKI
DXPCUVVW



STAINLESS STEEL



ALUMINUM
(BISON BLACK)

RENDER VIEW

The Dinex Portable Bar is great for snack and meal delivery in hallway or classroom in K-12. This flexible and functional cart lends itself anywhere from indoor to outdoor. When not in use it stores upright in only two square feet of space.

Standard Features

- Heavy-gauge, black vinyl clad aluminum exterior surfaces
- Stainless steel shelves
- Perimeter trim bumper
- Lockable cabinet latches
- Push handle

Dimensions

DXPPB5TBKES –
20.25"D x 56.37x 42.88"H

DXPPB5TBKMS –
20.25"D x 56.37L x 48.88"H

Standard Colors

- Custom colors available
- Optional graphics packages available

Casters

- Heavy duty; 2 stationary, 2 locking

Warranty

One year parts and labor.

***We do not accept returns on any Dinex equipment or Dinex custom products.
Please contact your local Dinex rep to ensure order accuracy prior to ordering.***

DINEX®

4711 E. Hefner Road
Oklahoma City, OK 73131
800.654.8210 | 405.475.5600
www.dinex.com

Rev 04/2020

Elementary Cart version

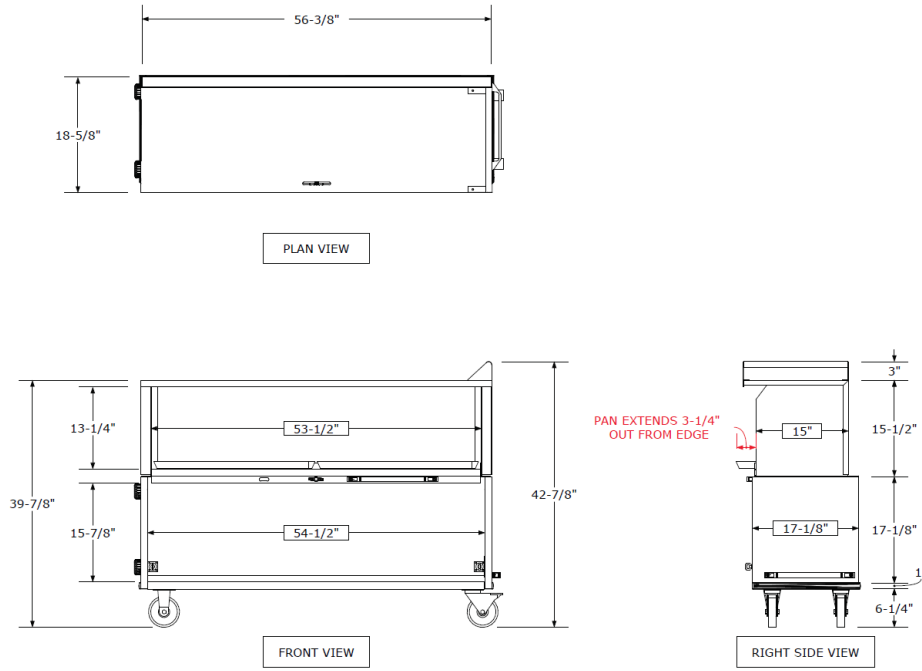

Middle School Cart Version

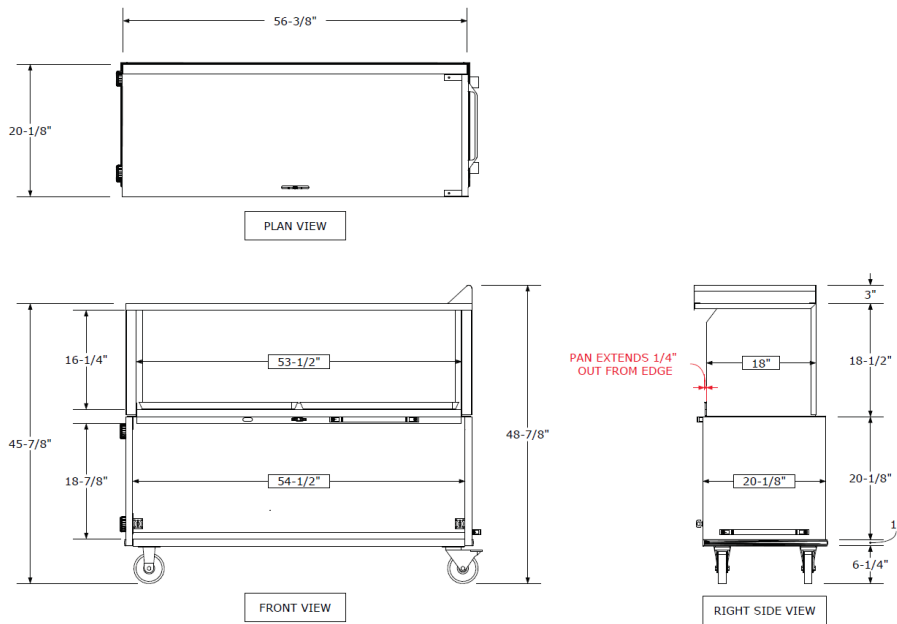

Items and Dimensions

ITEM NUMBER	DESCRIPTION	COLOR/CODE	LENGTH	DEPTH	HEIGHT (A)*	SHIP WEIGHT	SHIP CUBE
DXPPB5TBKES	Breakfast Bar, Elementary School	BK	56.37" (143cm)	20.25" (51cm)	42.88" (109cm)	140 lbs (64kg)	18.22
DXPPB5TBKMS	Breakfast Bar, Middle School	BK	56.37" (143cm)	20.25" (51cm)	48.88" (124cm)	140 lbs (64kg)	18.22

* Height includes casters

Please confirm that you have the most current specification sheet by visiting www.dinex.com.

It is Dinex's policy to offer equipment which is design certified by companies that have been accredited at the federal level by the Occupational Safety and Health Agency (OSHA) and ANSI as a national recognized testing laboratory. These companies include CSA International, Underwriters Laboratories, Edison Testing Laboratories and National Sanitation Foundation. However, a continuing program of product improvement makes it necessary to submit new models to the agencies as they are developed. Consequently, all models may not bear the appropriate labels at all times.

Dinex reserves the right to change specifications and product design without notice. Such revisions do not entitle the buyer to corresponding changes, improvements, additions or replacements for previously purchased equipment.

