



**TOP SHELF FULL DEPTH HAND SINKS**

**TSF SERIES 12" & 18"W x 24"D Hand Sink with Folded Paper Towel and Soap Dispensers**



JOB	
AREA	
ITEM NO.	
MODEL NO.	

<b>MODELS</b>
<b>TS Series</b>
TSF12HS
TSF18HS



**TSF12HS**  
(shown with faucet)



**TSF18HS**  
(shown with faucet)

**KEY PRODUCT FEATURES AND BENEFITS**

- Drawn, 18 gauge stainless steel sink bowl and work surface has a long life span and is dent resistant, even under heavy use.
- 16 oz. soap dispenser and C-fold or tri-fold paper towel dispenser integrated into the front apron for quick access.
- Soap dispenser easily refills from the top.
- Paper towel dispenser opens horizontally for easy access and refill.
- Paper towel positioned to minimize having to bend over to access paper towels for use.

**Additional Features:**

- All stainless steel construction.
- Our new, more robust Perlick Quick Clamp leg attachment still features easy tool-less installation, when legs are used.
- Optional Perlick Flex Mount leg relocation kit moves rear legs forward for additional space behind the equipment or moves forward legs rearward to help avoid pesky floor drains, available on TSF units.
- Stainless steel legs with adjustable thermoplastic feet install without tools for freestanding applications.
- Optional NSF-listed commercial-grade hot/cold water faucet stands up to years of use and can be easily serviced from the front.
- Optional side splashes.

\*Faucets must be ordered separately.

Form No. Z2966  
Rev. 08.30.24



**TOP SHELF FULL DEPTH HAND SINKS**

***TSF SERIES 12" & 18"W x 24"D Hand Sink with Folded Paper Towel and Soap Dispensers***

MODEL NUMBER - TSF12HSN, TSF18HS

MODEL NOS.		TSF12HS	TSF18HS
<b>DIMENSIONS: EXTERIOR</b>	Width In. (mm)	12" (305)	18" (457)
	Depth In. (mm)	24" (610)	
	Weight lb. (kg)	50 (23)	60 (27)
<b>MATERIALS</b>	Construction	All stainless steel	
	Top & Deck	18 gauge stainless steel	
	Front & Back	Seamless 18 gauge stainless steel	
	Backsplash	Stainless steel 6" high (4" high optional) with 1" return at the top, fastened and sealed to hand sink top	
	Legs	1-5/8" tubular, stainless steel with 1" adjustable thermoplastic feet	
	Bowl	Drawn, 18 gauge stainless steel. All horizontal and vertical edges 1-1/2" radius with balled corners. Furnished with 1-1/2" stainless steel drain socket. TSF18HS- (14"W x 10" front-to-back x 9" deep). TSF12HS- (10"W x 14" front-to-back x 9" deep).	
	Water Faucet	Faucets are heavy duty construction, chrome plated, lead free, and have the leads attached for easy hook up. <b>Faucet must be ordered separately.</b>	
<b>PLUMBING</b>	Drain Connection	1-1/2" NPS male. Hot and cold water connection	
	Water Connection	1/2" IPS shanks and nuts. 18" braided water supply lines.	

**Shown with optional faucet. Must be ordered separately.**

Form No. Z2966  
Rev. 08.30.24



**TOP SHELF FULL DEPTH HAND SINKS**

**TSF SERIES 12" & 18"W x 24"D Hand Sink with Folded Paper Towel and Soap Dispensers**

MODEL NUMBER - TSF12HSN, TSF18HS

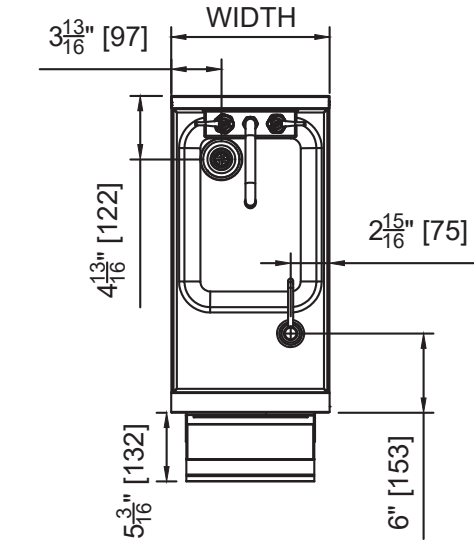

**TSF12HS**

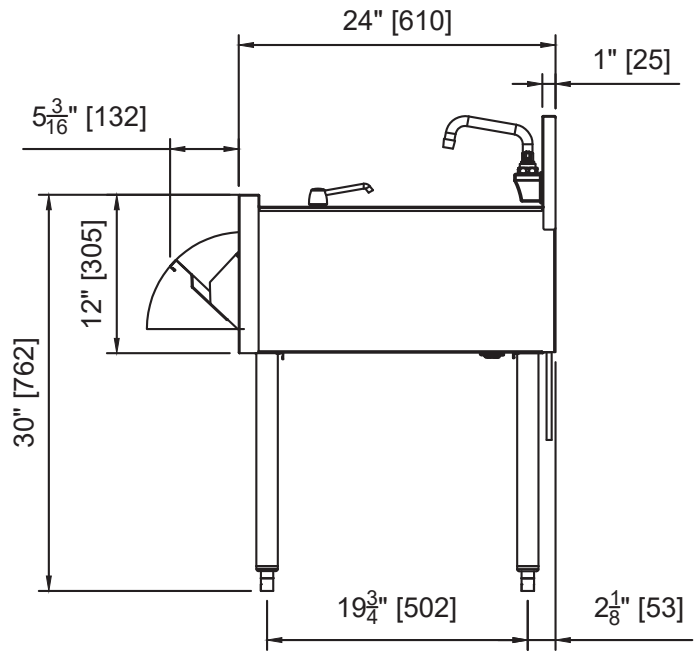
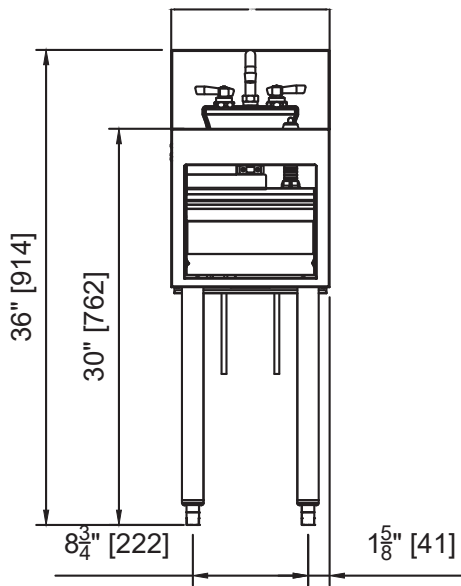

Shown with optional faucet. Must be ordered separately.

Form No. Z2966  
Rev. 08.30.24



**TOP SHELF FULL DEPTH HAND SINKS**

*TSF SERIES 12" & 18"W x 24"D Hand Sink with Folded Paper Towel and Soap Dispensers*

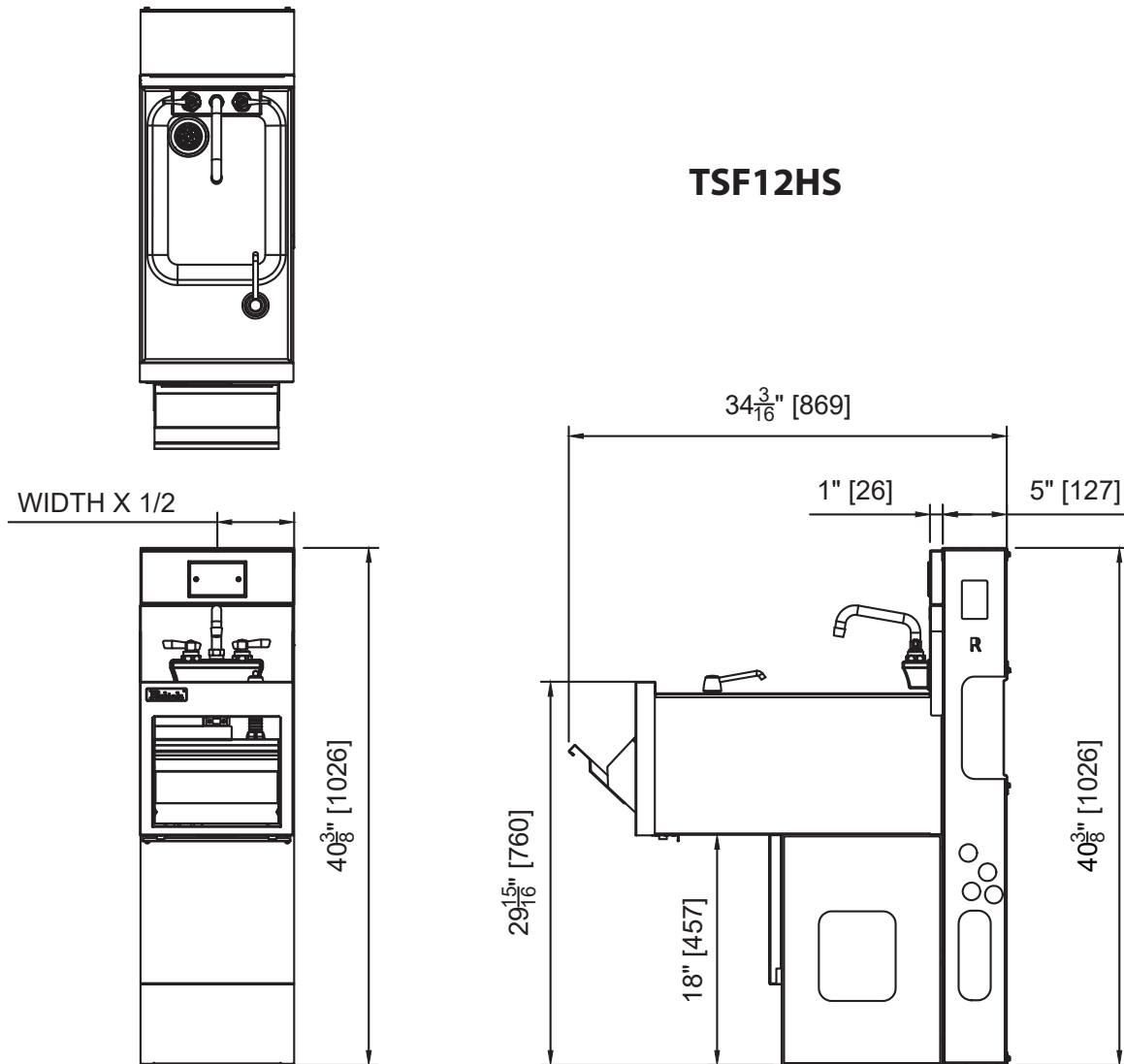

Shown with optional faucet. Must be ordered separately.

Form No. Z2966  
Rev. 08.30.24

**Perlick®** TOP SHELF FULL DEPTH HAND SINKS  
 TSF SERIES 12" & 18"W x 24"D Hand Sink with Folded Paper Towel and Soap Dispensers

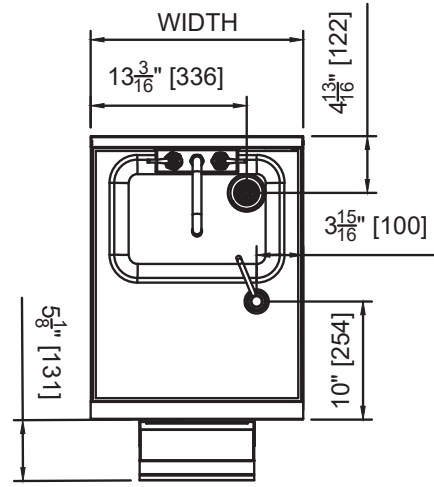

**TSF18HS**

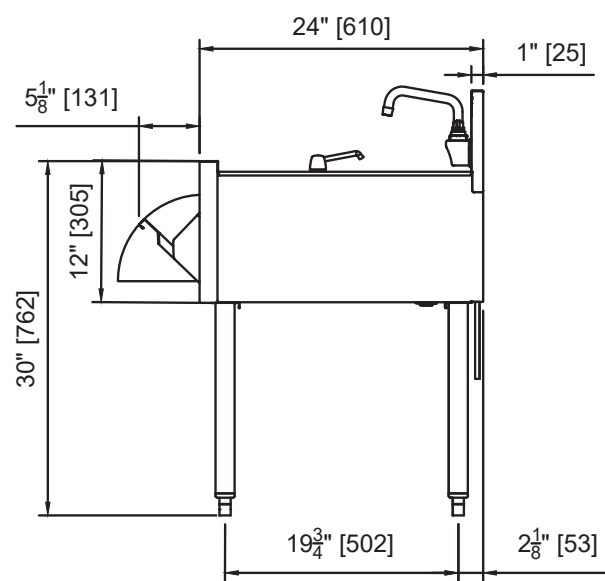
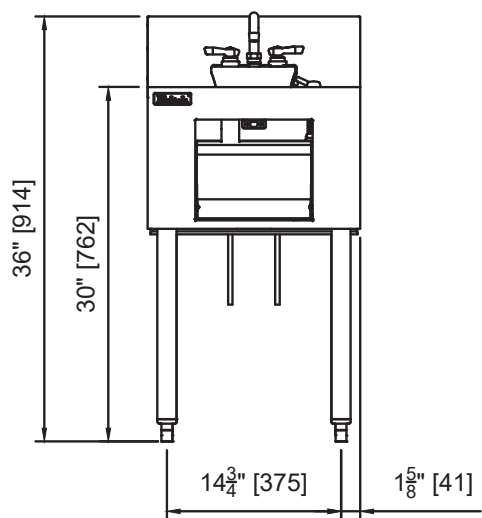

Shown with optional faucet. Must be ordered separately.

Form No. Z2966  
 Rev. 08.30.24

