

DINEXPRESS HOT FOOD COUNTERS

Compliant with
NSF/ANSI Standard 2



DXP3HF shown with optional
3-bar tray slide and formica finish

Item Numbers

DXP2HF
DXP3HF
DXP4HF
DXP5HF
DXP6HF

The versatile modular design of the DineXpress Serving System Hot Food Counters allows you to customize your cafeteria or a buffet line-up. Hot Food Counters are compatible and will interlock with other DineXpress units. This design allows the units to be disconnected for cleaning under the serving line. With DineXpress you choose only the options and accessories that you want and need for your line-up.

Dinex's equipment has the advantage of Food Safe technology and certification. This ensures that your food is kept out of the danger zone. Food spoilage occurs mainly because of rapidly accelerated bacteriological activity within the 40°F-140°F danger zone.

With Food Safe technology hot food stays above 140°F longer and cold food is kept below 40°F. Both are key factors in HACCP compliance and the fight against foodborne pathogens.

Standard Features

- 14-gauge stainless steel top with 1-1/2" turndown on all sides
- Top secured by four recessed bolts for easy access
- 14-gauge stainless steel legs fastened to
- 18-gauge stainless steel bottom shelf, open control side
- Open control side for additional storage capacity

- 20-gauge stainless steel end and front panels are attached to legs
- 20-gauge stainless steel bottom-mounted wells, 6-1/2" deep with coved corners
- 2" insulation on sides and between wells, 1-1/2" on bottom, 1" on the ends and 1/4" fiber frax all around
- 1000 watt tubular heating element for each well is individually and thermostatically controlled
- Wells can be run wet or dry
- 5" diameter swivel plate casters, 2 with brakes
- Interlocking mechanism is provided to interlock with other DineXpress units.
- Drain valve exits operator's left side as standard. Drain valve is 3/4" FPT.
- Common drains and manifolds

Dimensions

- DXP2HF – 36"H x 28"D x 32"L
- DXP3HF – 36"H x 28"D x 46"L
- DXP4HF – 36"H x 28"D x 60"L
- DXP5HF – 36"H x 28"D x 74"L
- DXP6HF – 36"H x 28"D x 88"L
- 36" height on all standard units
- 30" height is available on Petite Elite 500 units
- 28" width
- 32" to 88" length in 14" increments

Electrical

- Two, three and four well units are available, 120 volts
- All units available in 208 or 240 volt, single-phase standard
- Eight foot electrical cord and plug
- Some options or accessories may not be available with certain voltages

Common Options

- Pizzazz powder coating in lieu of stainless steel
- Tray slides
- Protector guards
- Hinged or sliding doors
- See reverse side for additional options

Warranty

One year parts and labor.

**We do not accept returns on any Dinex equipment or Dinex custom products.
Please contact your local Dinex rep to ensure order accuracy prior to ordering.**

DINEX®

4711 E. Hefner Road
Oklahoma City, OK 73131
800.654.8210 | 405.475.5600
www.dinex.com

DINEXPRESS HOT FOOD COUNTERS

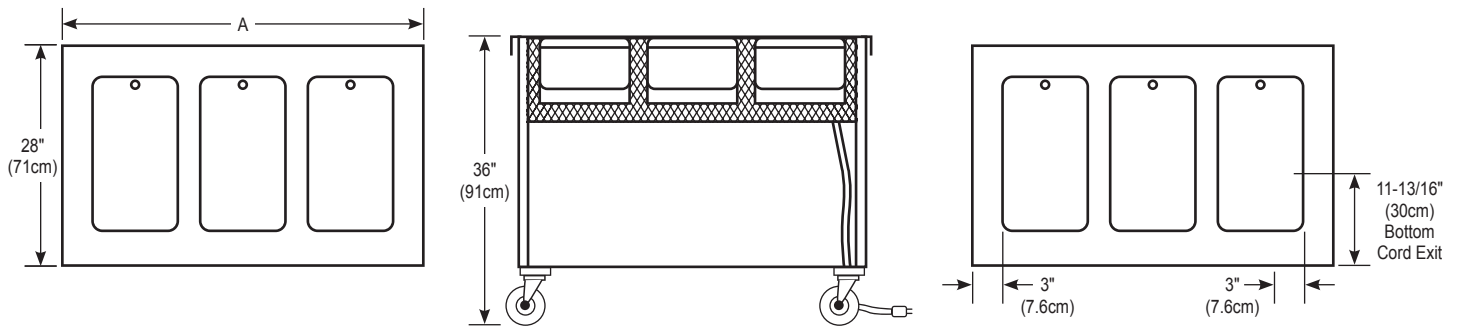

Items and Dimensions

ITEM NUMBER	NO. OF WELLS	LENGTH (A)	WIDTH	HEIGHT	WATTS	AMPS			NEMA CAP NUMBER			SHIP WEIGHT (LBS)
						120V	208V	240V	120V	208V	240V	
DXP2HF	2	32" (81cm)	28" (71cm)	36" (91cm)	2000	16.7	9.6	8.3	5-30P	6-15P	6-15P	300
DXP3HF	3	46" (117cm)	28" (71cm)	36" (91cm)	3000	25.0	14.4	12.5	5-50P	6-20P	6-20P	310
DXP4HF	4	60" (152cm)	28" (71cm)	36" (91cm)	4000	33.3	19.2	16.7	5-50P	6-30P	6-30P	335
DXP5HF	5	74" (188cm)	28" (71cm)	36" (91cm)	5000	N/A	24.0	20.8	N/A	6-30P	6-30P	375
DXP6HF	6	88" (224cm)	28" (71cm)	36" (91cm)	6000	N/A	28.8	25.0	N/A	6-50P	6-50P	400

Spacing between wells is 2". Floor clearance of unit is 6-1/4". Clearance height of open under storage is 17-3/4". Open under storage widths are 22-3/16", 36-3/16", 50-3/16", 64-3/16" and 78-3/16".

Dimension Additions For Options

- Add 23-3/4" to height for buffet protector guard
- Add 14" to height for cafeteria protector guard
- Add 22-3/4" to height for double display shelf
- Add 8" to width for cutting board

- Add 12-3/4" to width for solid ribbed tray slide
- Add 12-1/2" to width for 3-bar tray slide

Note: Line-up drawing required when ordering false front, cashier stand or interconnected units.

ITEM NO	DESCRIPTION
DXPPPC	PIZZAZZ POWDER COATING
DXPSCB	8" stainless steel cutting board, flush with top
DXPMCB	8" maple cutting board, flush with top
DXPSRTS	Solid 3-ribbed tray slide, 16-gauge stainless steel
DXP3BTS	3-bar tray slide
DXPMBS	18" maple end bread shelf; left, right - flush with top
DXPSBS	18" stainless steel end bread shelf; left, right - flush with top
DXPHD	Hinged doors with solid bottom
DXPSD	Sliding doors with solid bottom
DXPCPG	Cafeteria protector guard (no heat or lights)
DXPCPGL	Cafeteria protector guard with incandescent lights
DXPCPGFL	Cafeteria protector guard with fluorescent lights
DXPCEG	Cafeteria end guards, right or left
DXPINT	Intermediate shelf
DXPFPB	Full perimeter bumper

ITEM NO	DESCRIPTION
DXPBPG1	Buffet single side protector guard (no heat or lights)
DXPBPG1IL	Buffet single side protector guard with incandescent lights
DXPBPG1FL	Buffet single side protector guard with fluorescent lights
DXPBEG	Buffet end guards, right or left
DXPBDD	Buffet double display two-sided protector guard
DXPBPGC	Classic protector guards
DXPCPGC	Cafeteria Style Classic Single protector guard
DXPBPG1C	Buffet Style Classic Single Sided protector guard
DXPSCPGC	Cafeteria Style Classic Single protector guards
DXPSSL	Legs in lieu of casters
DXPDOUT	Duplex outlet (120V, 15 AMP)
DXPFRMA	Formica laminate finish
DXPFLP	Filler Strips
DXPFF	Fill Faucet
DXPSKR	Skirting

Please confirm that you have the most current specification sheet by visiting www.dinex.com.

It is Dinex's policy to offer equipment which is design certified by companies that have been accredited at the federal level by the Occupational Safety and Health Agency (OSHA) and ANSI as a national recognized testing laboratory. These companies include CSA International, Underwriters Laboratories, Edison Testing Laboratories and National Sanitation Foundation. However, a continuing program of product improvement makes it necessary to submit new models to the agencies as they are developed. Consequently, all models may not bear the appropriate labels at all times.

Dinex reserves the right to change specifications and product design without notice. Such revisions do not entitle the buyer to corresponding changes, improvements, additions or replacements for previously purchased equipment.

