



Project _____

AIA # _____ SIS # _____

Item # _____ Quantity _____ C.S.I. Section 114000

TU Series

Full Size Undercounter Refrigerators
Self-Contained
72" Two Door Models



(Shown with optional casters)

STANDARD PRODUCT FEATURES

- Stainless Steel Exterior & Interior Finish
- Reliable Microprocessor Control With LED Temperature Display
- Self-Contained Refrigeration System Using R-450A Refrigerant
- Front-Breathing Design for "Zero-Clearance" Installation
- Non-Electric Automatic Condensate Evaporator
- Off-Cycle Evaporator Defrost
- Controllable Anti-Condensate Drawer Perimeter Heaters
- Metal Door Handle with Gasket Guard
- Magnetic Snap-In EZ-Clean Door Gasket(s)
- Gasket-Protecting Stainless Steel Door Liner
- Self-Closing Door with Stay-Open Feature
- Stainless Steel Field Rehingeable Door
- Standard Door Hinging: Left/Right (other hings available)
- Two (2) Shelves Per Door
- 6" High Legs on Adjustable Channel System
- Thermostatic Expansion Valve Metering Device
- Side, Front & Rear Access Panel for Ease of Service & Maintenance
- Work Height 33.7" (85.6 cm)



Models listed to the applicable UL, CSA and NSF standards by an approved NRTL. Consult the factory or unit data plate for additional information.

AVAILABLE CONFIGURATIONS

One, Two & Three Door Models, 34" Deep

Model
TU072HT

Model Type
72" 2- Solid Door Model

ACCESSORIES & OPTIONS

- Stainless Steel Back
- Flat Stainless Steel Top with Bullnose Front
- Stainless Steel Top with 4" High Backsplash
- Stainless Steel Top with Drip Guard (Marine) Edge
- Set of 4" High Casters or 6" High Casters
- Two (2) or Three (3) Drawers in Lieu of any Door
- Cabinet length extension sections in 3", 6", 9", 12", and 15" sizes

Approved by _____ Date _____ Approved by _____ Date _____



TU Series

Full Size Undercounter Refrigerators
Self-Contained

MODELS

72" Two Door Models: TU072HT

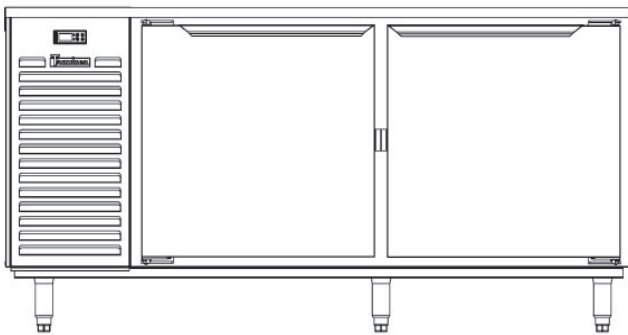

Elevation

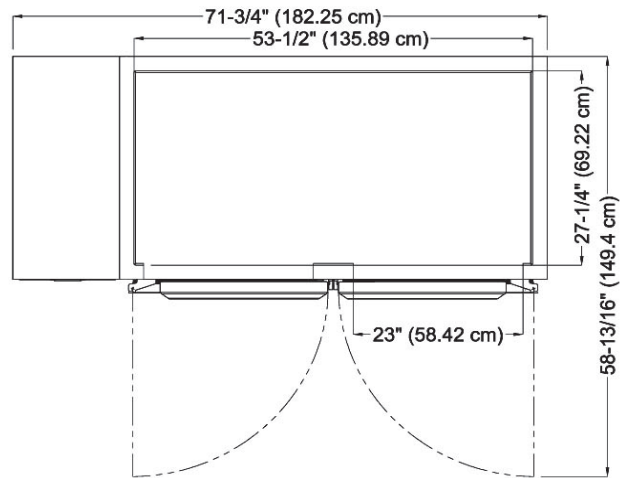

Top View

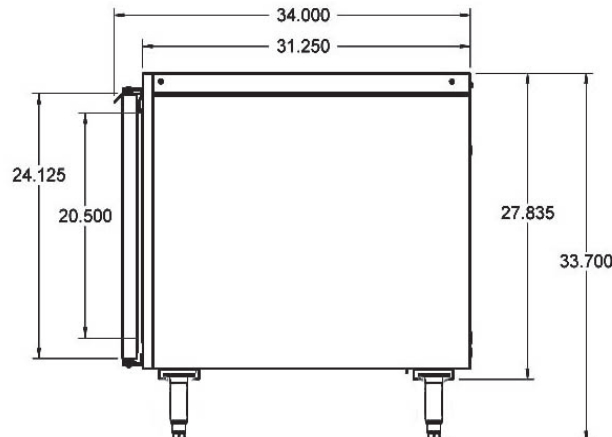

Section View

CAD and/or Revit Files Available

<https://traulsen.klccad.com/>



MODELS

TU072HT

MODELS	TU072HT
CABINET DIMENSIONAL DATA	
Net Capacity cu. ft.	20.0 (566 cu l)
Length - Overall in.	71 3/4 (182.2 cm)
Depth - Cabinet Only in.	31 1/4 (79.4 cm)
Depth - with Door Open 90°	58 13/16 (149.4 cm)
Depth - Overall in.	34 (86.4 cm)
Height - Overall on 6" Casters ¹ in.	33 7/10 (85.6 cm)
Height - Overall on 6" Casters ² in.	34 (86.4 cm)
Number of Shelves	4
Shelf Area sq. ft.	18.1 (1.7 sq m)
ELECTRICAL DATA	
Voltage	115/60/1
Plug	NEMA 5-15P
Full Load Amperes	5.3
MDEC ³	N/A
REFRIGERATION DATA	
Refrigerant	R-450A
Refrigerant Amount oz.	18 (510 gr)
BTU/HR HP ⁴	2460 1/3 HP
SHIPPING DATA	
Length - Crated in.	84 (213.4 cm)
Width - Crated in.	42 (106.7 cm)
Height - Crated in.	35 (88.9 cm)
Volume - Crated cu. ft.	71 (2010 cu l)
Weight - Crated lbs.	556 (252 kg)

NOTES:

1. Height as measured without optional stainless steel work top.
2. Height as measured with optional stainless steel work top.
3. MDEC= Maximum Daily Energy Consumption
4. Based on a 90°F ambient and 20°F evaporator.

When ordering please specify: Voltage, Hinging, Options and any additional warranties.

Equipped with one NEMA 5-15P Plug



EQUIPMENT SPECIFICATIONS

CONSTRUCTION, HARDWARE, INSULATION

Cabinet exterior front, sides, one-piece louver assembly and doors are constructed of stainless steel. Cabinet interior and door liners are constructed of stainless steel. The exterior cabinet sub-top, back and bottom are constructed of heavy gauge galvanized steel. A set of adjustable 6" high stainless steel legs are included. Doors are equipped with a gasket protecting metal door pan. A metal door handle with gasket guard is standard on all units. Gasket profile and durable long life material simplify cleaning and increase overall gasket life. Both the cabinet and door(s) are insulated with an average of 2" thick high density, non-CFC, foamed in place polyurethane.

INTERIOR

Standard interior arrangements include two (2) wire shelves per door, mounted on shelf pins. Recommended load limit per shelf should not exceed 225 lbs. Optional tray slides may be purchased in combination with, or in lieu of these. Both standard and optional interior arrangements are completely installed at the factory.

SELF-CONTAINED REFRIGERATION SYSTEM

The self-contained, balanced refrigeration system using environmentally friendly, non-flammable R-450A refrigerant features an off-cycle evaporator defrost, thermostatic expansion valve, air-cooled hermetic compressor, plenum effect blower coil, large, high humidity evaporator coil located outside the food zone and a non-electric automatic condensate evaporator. A 9' cord and plug is provided. Standard operating temperature is 34° to 38°F.

CONTROL

The easy to use water resistant microprocessor control is supplied standard. It includes a 3-Digit LED Display, and a Fahrenheit or Celsius Temperature Scale Display Capability.

WARRANTY

Both a six year parts and labor warranty and a seven year compressor warranty (self-contained models only) are provided standard.