

BACK BAR EQUIPMENT

Model: **KC24NSS**

Natural Refrigerant R-290 Model

24" Keg Cooler

Stainless steel exterior, countertop and interior back with reinforced stainless steel floor.



Options and Accessories

(upcharge and lead times may apply)

Epoxy coated or stainless steel shelves	Single, dual or triple faucets
Hinged glass door (consult factory)	Faucet lock
Food storage rated stainless steel interior (NSF-7)	

Consult factory for other model configurations, options and accessories.

Project Name:

Model Specified:

Location:

Item No:

Quantity:

AIA #:

SIS #:

Standard Model Features

REFRIGERATION SYSTEM

Performance rated refrigeration system

Natural, environmentally safe, high efficiency R-290 refrigerant¹

Automatic, hot gas condensate evaporator

Extra large, balanced evaporator coil

CABINET ARCHITECTURE

High density, non-CFC polyurethane foamed-in-place insulation

Rear and side venting louvered panels

Magnetic snap in door gasket

Cylinder-keyed security lock

Stainless steel reinforced threshold

5" high casters (cannot be changed, footing installed)

MODEL FEATURES

Electronic controller with digital display & hi-low alarm

Continuously cooled, 3" diameter beer column with lever faucet, CO₂ pressure relief distributor and CO₂ tubing with clamps

Easily removable stainless steel drip grate with convenient front mounted cleanout drainage hose (pan not removable)

Easily accessible and serviceable condensing unit

¹ R-290 refrigerant meets all federal and state regulatory requirements.

Continental
Refrigerator

Toll-Free: 800-523-7138
Phone: 215-244-1400
Fax: 215-244-9579

539 Dunksferry Road
Bensalem, PA 19020
www.continentalrefrigerator.com

APPROVAL:

Model Specifications

DIMENSIONAL DATA

Net Capacity (cubic feet)	8 (226 cu l)
Width, Overall (inches)	24 1/8 (613 mm)
Depth, Overall (inches) (including handle & condenser)	31 7/16 (798 mm)
Height, Overall (inches) (not including column)	38 13/16 (986 mm)
Capacity: # Barrel Kegs	1
Capacity: # Straight Wall Kegs	1
Capacity: # 1/6 Size Kegs	3
Number of Doors	1
Number of Beer Columns (with single faucet)	1

REFRIGERANT DATA

Condensing Unit Size (H.P.)	1/5
Capacity (BTU per hour)*	1620

ELECTRICAL DATA

Voltage (International)	115/60/1 (220/50/1)
Feed Wires (including ground)	3
Total Amps (International)	2.5 (2.7)
10 ft. Cord/Plug [attached] (International)	Yes (No)

SHIPPING DATA

Weight (pounds)	220 (100 kg)
Height - Crated (inches)	43 1/4 (1099 mm)
Width - Crated (inches)	35 3/4 (908 mm)
Depth - Crated (inches)	37 1/4 (946 mm)

* Rating @ +25°F evaporator, 90°F ambient
Figures in parentheses reflect metric equivalents rounded to the nearest whole unit.



Equipped with one NEMA-5-15P Plug
(varies by country)

Continental[®]

Refrigerator

Toll-Free: 800-523-7138
Phone: 215-244-1400
Fax: 215-244-9579

539 Dunksferry Road
Bensalem, PA 19020
www.continentalrefrigerator.com

Due to our continued efforts in developing innovative products, specifications subject to change without notice.



© Copyright 2021. Continental Refrigerator.
A Division of National Refrigeration & Air Conditioning Products, Inc.

Model Plan Views

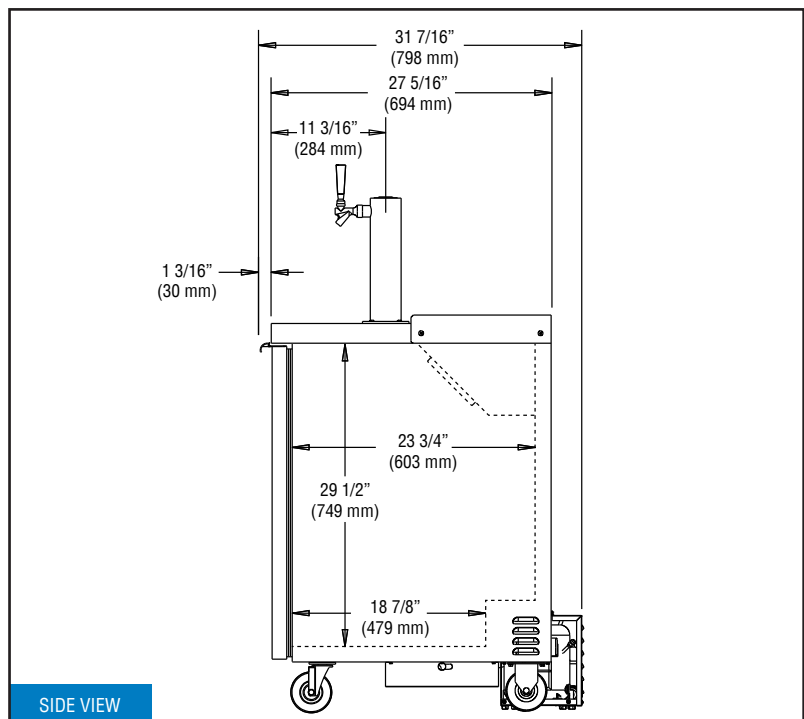
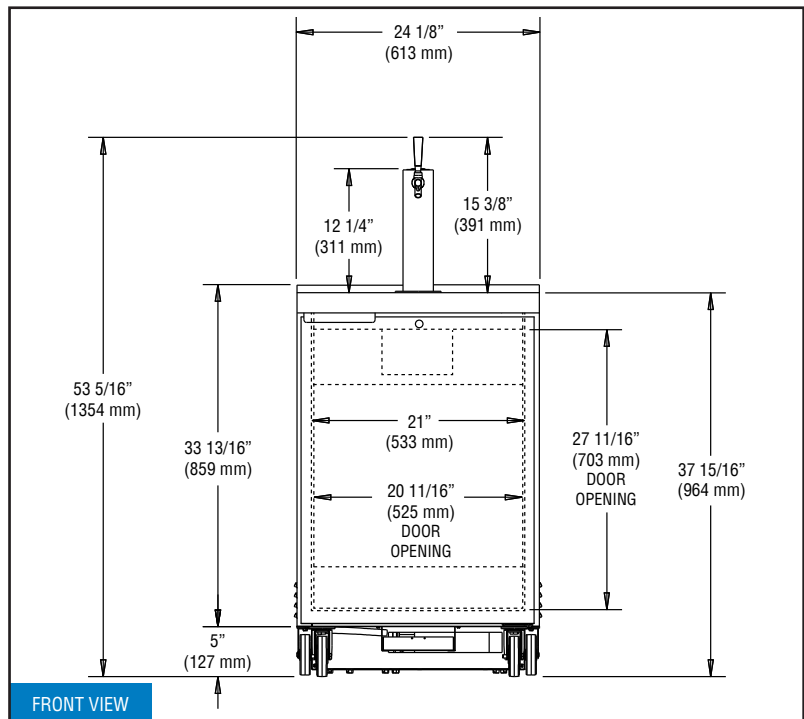

IMPORTANT NOTE: If the cabinet is located directly against a wall, a minimum clearance of 3" is required on sides, front and rear.

REVISED: 5/10/2022