

APPLICATION:
JOB NAME:

PRODUCT NAME:
DrainKing WASTE VALVE

QUANTITY: ITEM NO.

SPECIAL CONFIGURATION
CHECK BASE MODEL AND OPTIONS

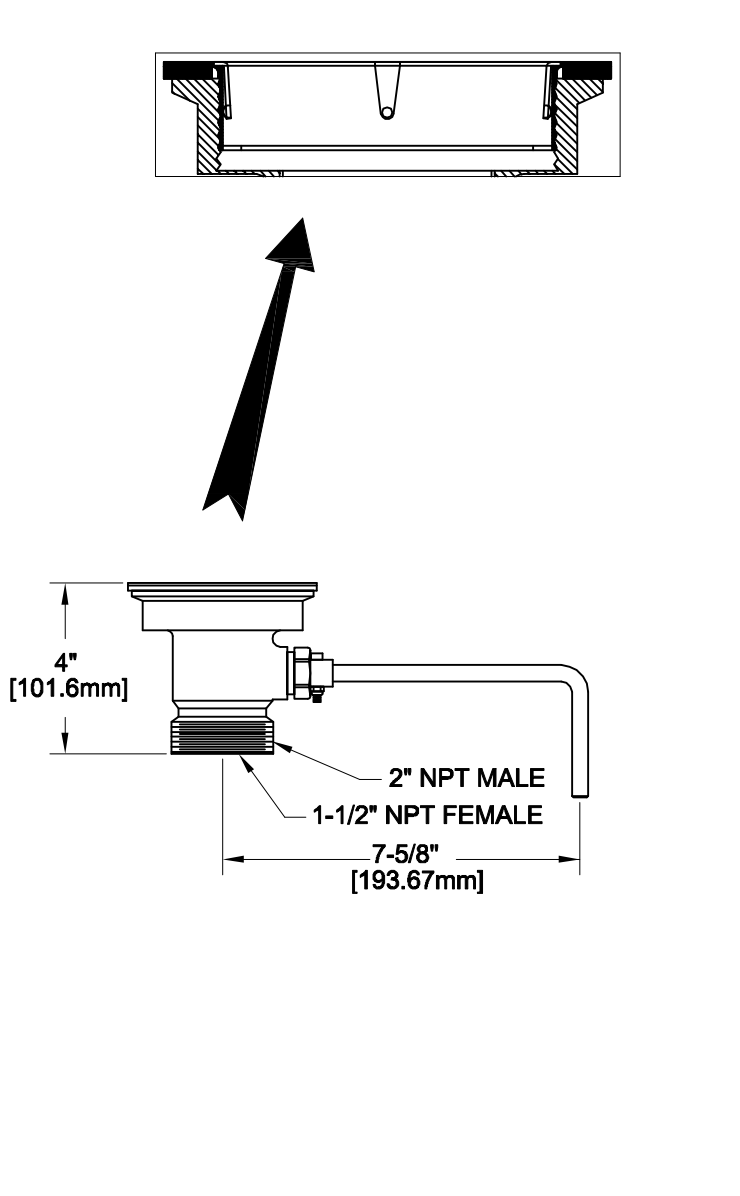

MODEL:
 52434 WITH FLAT STRAINER

OPTIONS OR MODIFICATIONS:
 OTHER _____

- FEATURES:
- * DUAL TEFLON SEALS
 - * STAINLESS STEEL BALL
 - * CAST RED BRASS BODY
 - * EXTRA STURDY STAINLESS STEEL CLAMPING RING
 - * "CLEAR THROUGH" OPENING - NO NEED TO DISASSEMBLE IF SNAKING IS REQUIRED
 - * INDUSTRY STANDARD "SEALING" ANGLE - FITS FLUSH TO STANDARD STAINLESS STEEL SINKS
 - * STAINLESS STEEL FLAT STRAINER
 - * 1/4 TURN FULLY OPENS AND CLOSES VALVE

DRAIN RATE:
* 12 GPM

SHIPPING WEIGHT

ROUGH-IN:

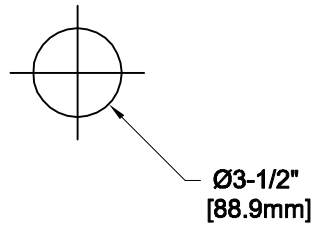

ANSI/A112.18.1M

FISHER
 FISHER MANUFACTURING COMPANY
 TOLL FREE: 800-421-6162 - FAX: 800-832-8238
 information@fisher-mfg.com - www.fisher-mfg.com