



# EMPower Gas Charbroiler Top - 12"

ITEM # \_\_\_\_\_

MODEL # \_\_\_\_\_

NAME # \_\_\_\_\_

SIS # \_\_\_\_\_

AIA # \_\_\_\_\_



Electrolux

EMPower  
Gas Charbroiler Top - 12"



EMPower  
Gas Charbroiler Top - 12"

169119 (AGG12)

EMPower Restaurant Range charbroiler, 12" wide, gas, 33,000 BTU, cast iron radiants with 4" adjustable, removable legs

splashback may be easily disassembled for cleaning. Special heavy duty chrome plated knob for durability and easy cleaning. The configuration of bezel and knob provides high level of protection against water infiltrations. Right-angled side edges to allow flush fitting joints between EMPower units. Supplied with 4" (102mm) height adjustable, removable legs. EMPower unit may be installed on refrigerated base or open cupboard.

## Short Form Specification

### Item No.

EMPower unit to be Electrolux Gas Charbroiler Top with single high efficiency 33,000 BTU (9.6 kW) burner. Control knob provides smooth, continuous rotation from min to max. Suitable for natural gas or propane gas. Heavy duty, double-sided, removable cast iron radiants to provide attractive char-broil markings and unmistakable char-broiled taste. 6" (153 mm) radiant sections may be removed easily and safely for cleaning. Special system utilizing stainless steel deflective shields below the radiants (PATENT PENDING) prevents clogging of burner, minimizes flare ups and provides even heat distribution. Full length, half gal. (2 l) grease collector drawer with hole to indicate when full, captures all excess grease and oil and can be extracted for easy dumping and cleaning. Grease collector drawer may be filled with water to facilitate cleaning. Full width, removable grease gutter on front. No tools are needed to remove grates, radiant covers, stainless steel burner, splashback and grease gutter. All major components can be accessed from the top and front of the appliance for ease of maintenance. Worktop in AISI 304 Stainless Steel. Front and side panels in Stainless Steel with Scotch Brite finish. removable



APPROVAL: \_\_\_\_\_



### Main Features

- Single high efficiency gas 33,000 BTU (9,6 kW) burner.
- Burner with optimized combustion and protected pilot light.
- Flame failure device to protect against accidental extinguishing of the flame.
- Control knob provides smooth, continuous rotation from min to max.
- Heavy duty, double-sided, removable cast iron radiants to provide attractive char-broil markings and unmistakable char-broiled taste.
- 6" (153 mm) radiant sections may be removed easily and safely for cleaning.
- Special system utilizing stainless steel heat spreading shields below the radiants (PATENT PENDING) avoiding burner clogging and minimizing flare ups while providing an even heat distribution throughout the cooking surface.
- Full length, half gal. (2 l) grease collector drawer with hole to indicate when full, captures all excess grease and oil and can be extracted for easy dumping and cleaning.
- Grease collector drawers may be filled with water to facilitate cleaning.
- Full width, removable grease gutter on front.
- No tools are needed to remove grates, radiant covers, stainless steel burner, splashback and grease gutter.
- Removable splashback may be easily disassembled for cleaning.
- All major components can be accessed from the top and front of the appliance for ease of maintenance.
- Front and side panels in Stainless Steel with Scotch Brite finish.
- Special heavy duty chrome plated knob for durability and easy cleaning.
- The configuration of bezels and knobs provides high level of protection against water infiltrations.
- Right-angled side edges to allow flush fitting joints between units, eliminating gaps and possible dirt traps.
- Provided with kit for side-by-side connection between units for minimizing gaps and possible dirt traps.
- Supplied with 4" (102mm) height adjustable, removable legs.
- Unit may be installed on refrigerated base by removing the legs and inserting the special pins (optional accessory).
- Unit may be installed on open cupboard by removing the legs and inserting the screws provided as standard with the open cupboards.
- Included Accessories: propane converter kit, pressure regulator and main shut off valve.
- In compliance with ETL Certification (UL & NSF).
- Configured for Natural Gas, LP Conversion Kit Included.

- EMPower back mounted rear shelf-spacer, 12" unit  PNC 169096
- Portioning Shelf 12"  PNC 169173

### Construction

- Worktop in 304 AISI stainless steel.
- 4 screws to install on the cupboard base are supplied with the unit.
- Gas pressure regulator is supplied with the unit.

### Optional Accessories

- EMPower - 4 pins to fix top to refrigerated/open base  PNC 169048
- EMPower scraper & hooks for charbroiler  PNC 169082

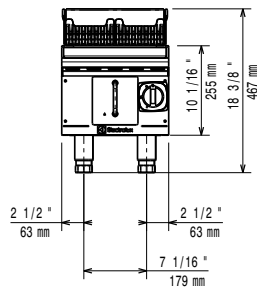
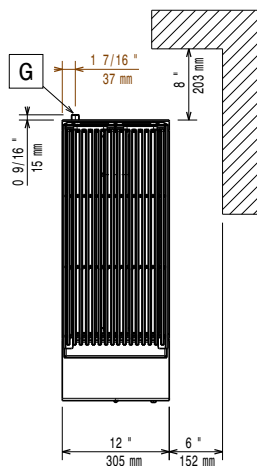
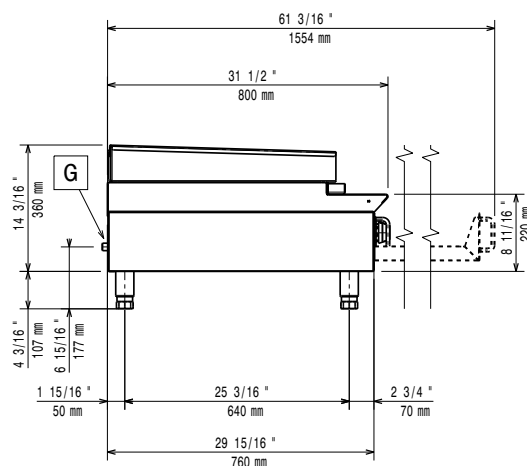
**Front**

**Top**

**Side**

**EQ = Equipotential screw**
**G = Gas connection**
**Gas**
**Gas Power:**
**169119 (AGG12)** 33000 Btu/hr (9.6 kW)

**Gas Power:**

33000 Btu/hr (9.6 kW)

**Gas Type Option:**

;Propane

**Gas Inlet:**

1/2"

**Key Information:**
**External dimensions, Width:** 12 1/64" (305 mm)

**External dimensions, Depth:** 31 1/2" (800 mm)

**External dimensions, Height:** 18 3/8" (467 mm)

**Net weight:** 66 lbs (30 kg)

**Shipping width:** 35 7/16" (900 mm)

**Shipping depth:** 14" (355 mm)

**Shipping height:** 25 1/2" (648 mm)

**Shipping weight:** 77 lbs (35 kg)

**Shipping volume:** 7.31 ft<sup>3</sup> (0.21 m<sup>3</sup>)

\*The rear and side clearances shown on the diagram indicate the minimum distances recommended from the appliance to combustible surfaces.