

# MAXIMIZER

## Bake & Roast Ovens

MODEL CW52B

### General Features:

- **Quality Construction** for long life
- **Stainless Steel Front Standard**  
Stainless top & sides available (T430)
- **Heavy Duty Steel Deck** with flanged sides (16A)
- **Center Wire Rack** (optional)
- **4-Cell "Power-Pak" Burner System** for better distribution of heat and better baking ability
- **Thermostat**  
250° F - 550° F (121°C - 288°C) Standard  
150° F - 500° F (66°C - 260°C) Optional
- **Space Saver**  
Only 50" wide
- **Stackable Up To Three Units**  
Multiple options for flexibility
- **Aluminized Interior** Standard
- **Easily Serviceable**  
Most controls can be replaced from the front of the unit
- **Power**  
Gas - LP or NAT
- **Specific Features** of the CW52B listed on back

### Warranty:

- One year parts and labor



**GAS  
FIRED**



Steel Decks / Wire racks optional

Steel Deck  
Baffle  
Burner

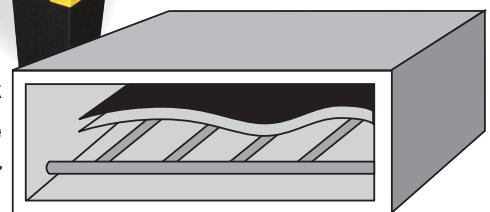

"Power-Pak" 4-Cell Burner System

## MORE FOR LESS

More Cooking Space per Floor Space  
More Cooking Capacity per Sales Dollar  
More Performance per Gas Dollar

 **Peerless**  
Commercial and Industrial Ovens

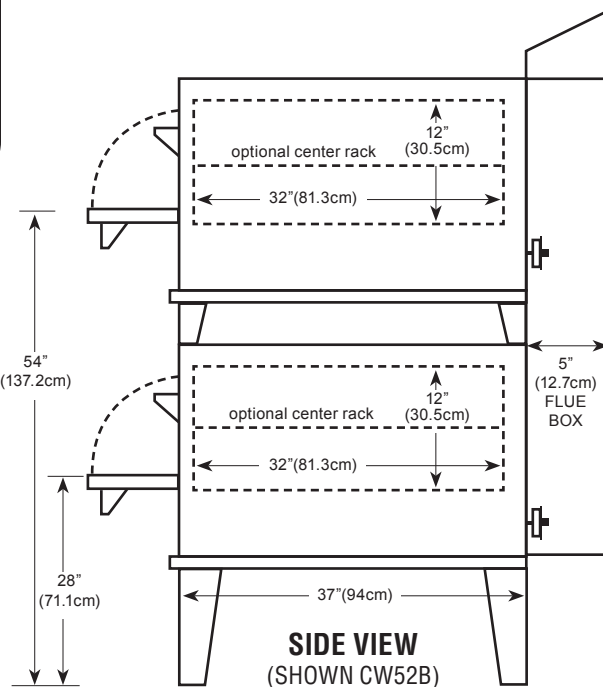
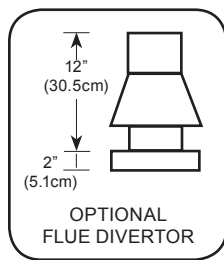
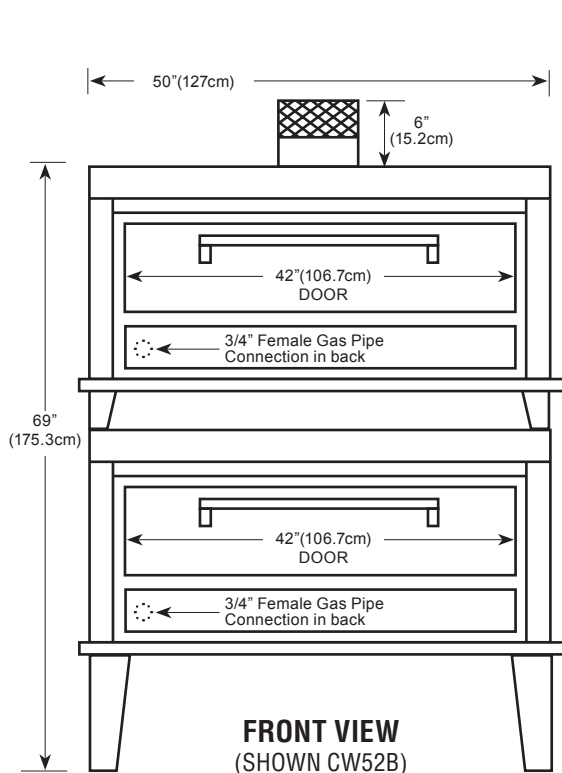

Floor space	50" (127cm) wide x 42" (106.7cm) deep* x 69" (175.3cm) high
Shelf size	42" (106.7cm) wide x 32" (81.3cm) deep x 12" (30.5cm) high
Shipping weight	1550 lbs (703kg)
Capacity	Two 18"x26" bun pans per section
Gas	Maximum 60,000 BTU input each
Opening required for installation: 25" * Handle adds 2.5" (6.4cm) to depth	

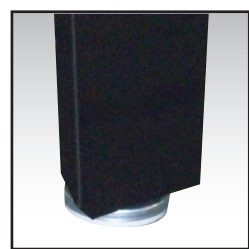

Adjustable Legs

### Durable Construction

The CW52B is built with *prime 20-gauge cold-rolled top and sides* with a 14-gauge base. The *interior is made of Armco Type 1, 20-gauge aluminized steel*. The CW52B comes standard with stainless steel front, or optional all stainless steel finish. The stainless steel is made of high quality, 18-gauge 430 stainless; the door interior is 18 gauge stainless.

### Energy Efficiency

The CW52B features our *new energy-saving "Power-Pak" 4-cell burner system* and our *unique baffle system*. These make our ovens highly efficient and eliminate hot spots. The *heavily insulated walls*, coupled with our *special vent system*, reduces heat loss and keep your gas dollars from going up the stack. The CW52B is powered by 60,000 highly efficient BTUs which *increases its efficiency and recovery rate*.

### Capacity

The CW52B deck size measures 42"x32"x12" (2). The CW52B will hold four 18"x26" bun trays per oven. Cook time will vary according to product. Optional two piece racks are available to increase capacity.

### Space Saver

Because the controls are under the door, the CW52B requires *less installation space* than our competition. This enables you to free up valuable kitchen and/or hood space. The actual width needed is a mere 50" for two 42"x32" decks, almost a foot less than the competition. The CW52B *can convert into a CW53BSC by stacking*, either initially or after your business grows. This option gives you three 42"x32" decks in only 56" of space as the CW53B becomes a SC.

### Design Plus

The CW52B has the *controls in lower front for ease of operation and space savings*. This also places the controls in their own *air-conditioned area* so they are not affected by outside influences. In addition, the CW52B is *totally thermocoupled* and allows you to replace individual parts as opposed to throwing away the whole system.

