



# Open Base Riser Top Work Table

*Stainless Steel Work Tables*



Use your smart phone to scan the above QR code to visit our website:  
www.bk-resources.com

## Certifications:



## Features:

- 1 5/8" Legs
- 5" Riser
- Legs Adjust 1" in Height
- Ships KD
- Two (2) Sound Deadened 2" Rectangular Steel Tubing to Reinforce and Maintain Level Working Surface
- 96" & 84" Tables Have 6 Legs

## Options:

- Single & Double Overshelves
- Drawer Assemblies
- Casters
- Adjustable Table Mount Pot Rack



## Material:

- T-304 14 ga. Stainless Steel Top
- Stainless Steel Legs & Bracing
- 1 1/4" Adjustable Stainless Steel Feet

| Part #       | Length | Width | Product Weight (lbs) | Capacity |
|--------------|--------|-------|----------------------|----------|
| QVTR50B-3030 | 30"    | 30"   | 47.50                | 900      |
| QVTR50B-3630 | 36"    | 30"   | 55.00                | 900      |
| QVTR50B-4830 | 48"    | 30"   | 72.50                | 900      |
| QVTR50B-6030 | 60"    | 30"   | 85.00                | 650      |
| QVTR50B-7230 | 72"    | 30"   | 100.00               | 420      |
| QVTR50B-8430 | 84"    | 30"   | 119.00               | 1350     |
| QVTR50B-9630 | 96"    | 30"   | 130.00               | 1350     |

| Part #       | Length | Width | Product Weight (lbs) | Capacity |
|--------------|--------|-------|----------------------|----------|
| QVTR50B-2424 | 24"    | 24"   | 39.00                | 900      |
| QVTR50B-3024 | 30"    | 24"   | 42.50                | 900      |
| QVTR50B-3624 | 36"    | 24"   | 46.00                | 900      |
| QVTR50B-4824 | 48"    | 24"   | 68.50                | 900      |
| QVTR50B-6024 | 60"    | 24"   | 81.50                | 650      |
| QVTR50B-7224 | 72"    | 24"   | 92.00                | 420      |
| QVTR50B-8424 | 84"    | 24"   | 111.00               | 1350     |
| QVTR50B-9624 | 96"    | 24"   | 127.00               | 1350     |

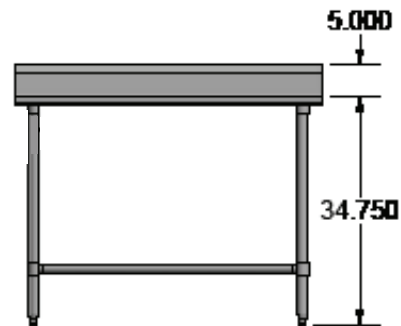
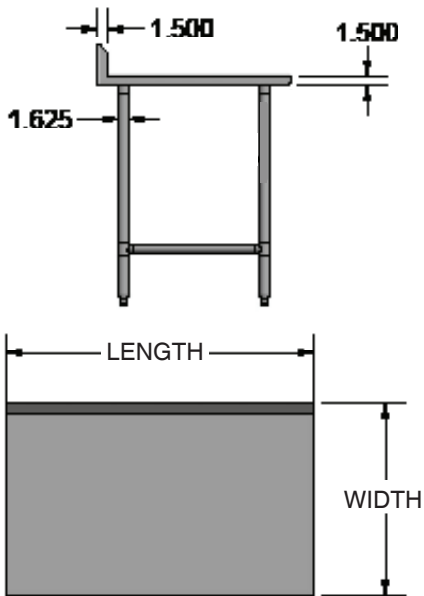

1.250 Adjustable Stainless Steel Feet

PRODUCT DATA SHEET

BK RESOURCES

