



HOSHIZAKI



MEGA TOP PREP TABLES

FULL SIZE PAN RAIL CAPACITY

SR27A-12M, SR48A-12M, SR60A-12M CRMR27-12M, CRMR48-12M, CRMR60-12M	SR36A-15M CRMR36-15M	SR48A-18M, SR60A-18M, SR72A-18M CRMR48-18M, CRMR60-18M, CRMR72-18M
<p>(2) Full size pans</p>	<p>(2) Full size pans + (3) 1/6 pans</p>	<p>(3) Full size pans</p>
SR60A-24M, SR72A-24M CRMR60-24M, CRMR72-24M		SR72A-30M CRMR72-30M
<p>(4) Full size pans (2 per opening)</p>		<p>(5) Full size pans (3 in left opening, 2 in right opening)</p>

PAN SIZE	FULL SIZE			2/3 SIZE			1/2 SIZE			1/2 SIZE LONG			1/3 SIZE			1/4 SIZE			1/6 SIZE			1/9 SIZE	
	12 3/4" x 20 3/4"			13 3/4" x 12 3/4"			12 3/4" x 10 3/8"			20 3/4" x 6 7/16"			12 3/4" x 6 7/8"			10 3/8" x 6 3/8"			6 7/8" x 6 1/4"			6 3/4" x 4 1/4"	
Pan Depth	2-1/2"	4"	6"	2-1/2"	4"	6"	2-1/2"	4"	6"	2-1/2"	4"	6"	2-1/2"	4"	6"	2-1/2"	4"	6"	2-1/2"	4"	6"	2-1/2"	4"
Cups	36	60	88	24	40	57	16	28	40	16	28	40	10.5	18	26	6.4	12	19	10.5	18	26	2.5	5
Quarts	9	15	22	6	10	14.25	4	7	10	4	7	10	2.6	4.5	6.5	1.6	3	4.75	2.6	4.5	6.5	.63	1.25

- Pans by others. Full complement of 1/6 size pans, 4" deep, and divider bars are included. Pan sizes are industry standard, but actual sizes may vary slightly by manufacturer.

FULL SIZE PAN EQUIVALENCY CHART

- Additional divider bars may be required to accommodate above pan layouts (Individual divider bars sold as Accessories).

➡ Divider bars on the back...

#52001 | 9/17/2018



HOSHIZAKI



Divider Bars – Configuration Sheet

Divider Bar Configuration in Mega Top Prep Tables

Center divider bars have notches to accept interlocking side divider bars.

- Provides stability for pan placement by preventing side bars from sliding out of position that could allow pans to fall into cabinet below.
- Increased flexibility for user because center notches allow user to easily re-configure bars to accept desired pan sizes for their unique menu.
- Made of high quality stainless steel insures long life.

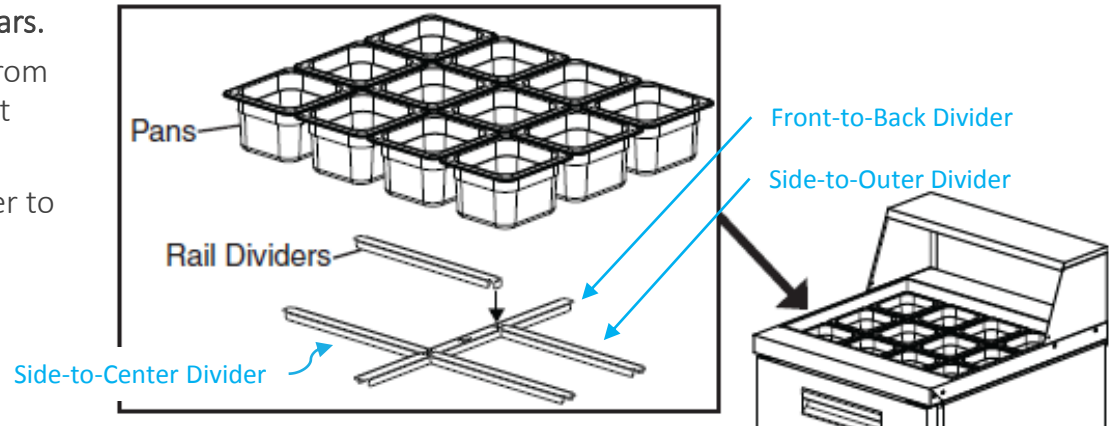

↻ Pan Capacity on the front...

Front-to-Back Divider



HS-5184 – All Mega Top models
One divider bar per kit

Side-to-Outer Divider



HS-5185 – All Mega Top models
One divider bar per kit

Side-to-Center Divider



HS-5186 – 15M, 18M & 30M
One divider bar per kit

INCLUDED DIVIDER BARS

SR27A-12M, SR48A-12M, SR60A-12M

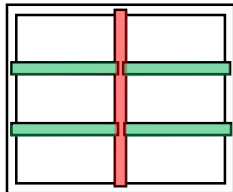

- (1) **HS-5184**: Front-to-Back Divider (20-3/4"; 526 mm)
- (4) **HS-5185**: Side-to-Outer Divider (12-1/2"; 319 mm)

SR36A-15M

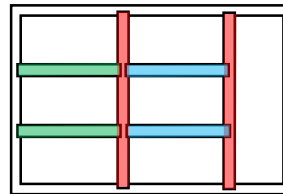

- (2) **HS-5184**: Front-to-Back Divider (20-3/4"; 526 mm)
- (2) **HS-5185**: Side-to-Outer Divider (12-1/2"; 319 mm)
- (2) **HS-5186**: Side-to-Center Divider (12-1/2"; 316 mm)

SR48A-18M, SR60A-18M, SR72A-18M

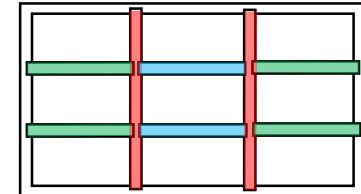

- (2) **HS-5184**: Front-to-Back Divider (20-3/4"; 526 mm)
- (4) **HS-5185**: Side-to-Outer Divider (12-1/2"; 319 mm)
- (2) **HS-5186**: Side-to-Center Divider (12-1/2"; 316 mm)

SR60A-24M, SR72A-24M

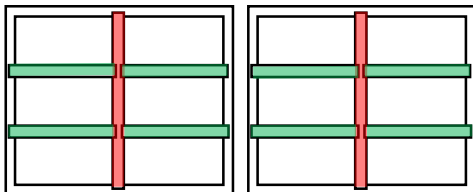

- (2) **HS-5184**: Front-to-Back Divider (20-3/4"; 526 mm)
- (8) **HS-5185**: Side-to-Outer Divider (12-1/2"; 319 mm)

SR72A-30M

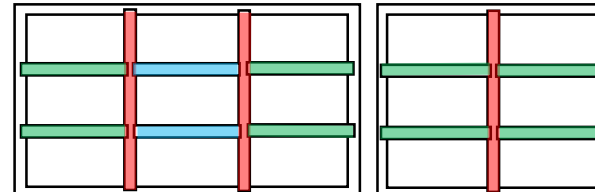

- (3) **HS-5184**: Front-to-Back Divider (20-3/4"; 526 mm)
- (8) **HS-5185**: Side-to-Outer Divider (12-1/2"; 319 mm)
- (2) **HS-5186**: Side-to-Center Divider (12-1/2"; 316 mm)