

Item: _____	Model #: _____
Quantity (Qty): _____	Project: _____

Salamander Broiler

O24SB | O36SB



O36SB

The **Salamander Broiler** was developed to provide the best cooking experience, combining high standard quality, performance and durability to satisfy all professional kitchens demands.

STANDARD FEATURES

- Available in 24" (610 mm) and 36" (915 mm) width.
- Stainless steel front and sides.
- One (O24SB) or two (O36SB) infrared burners, each individually controlled.
- 1-year parts and labor warranty.
- Standing pilot ignition system.
- Heavy-duty nickel-plated rack and 4 position rack carriage.
- Aluminum knobs providing for better toughness and durability.
- Full width grease deflector channels hot drippings to a large capacity drip pan.
- Removable drip pan and rack for easy cleaning.
- Product installation kit (pressure regulating valve).
- Propane Gas (LP) Conversion Kit.

OPTIONS & ACCESSORIES

- Adjustable 4" chrome-plated carbon steel legs.
- Stainless steel reinforced back riser for range mounting.
- Set of wall mount brackets.

AREA FOR CONSULTANT / CONTRACTOR:

Salamander Broiler

O24SB | O36SB

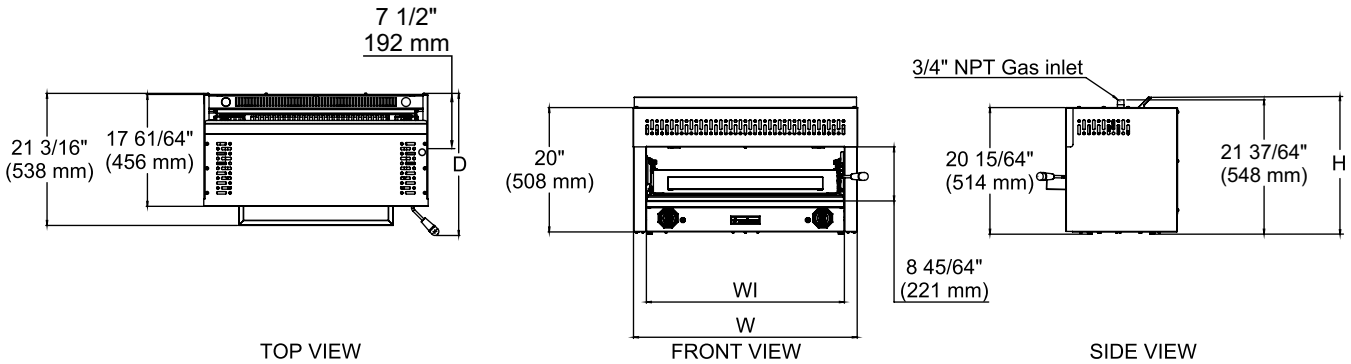

Model	Product Dimensions & Weight					Shipping Crate Dimensions & Weight			
	Width (W)	Interior Width (WI)	Depth (D)	Height (H)	Weight	Width	Depth	Height	Weight
O24SB	24" (610 mm)	19 11/16" (500 mm)	22 19/32" (574 mm)	21 31/32" (558 mm)	125 lb (57 kg)	28 5/32" (715 mm)	24 13/64" (640 mm)	29 21/64" (745 mm)	139 lb (63 kg)
O36SB	36" (915 mm)	31 57/64" (810 mm)			185 lb (84 kg)	40 1/32" (1017 mm)			205 lb (93 kg)

UTILITY INFORMATION

GAS SUPPLY					
MODEL	QUANTITY OF BURNERS	NATURAL	PROPANE	MANIFOLD PRESSURE	
		BTU/h	BTU/h	NATURAL GAS	PROPANE GAS
O24SB	1	20,000	20,000	5" W.C	10" W.C
O36SB	2	40,000	40,000		

SPECIFICATIONS

- 20,000 BTU per infrared burner.
- Manifold pressure is 5" W.C (Natural Gas) or 10" W.C (Propane Gas).
- 3/4" NPT top gas connection and pressure regulator for both natural gas and propane.
- Check the altitude specifications above 2,000 ft.
- Specify the type of gas when ordering.

INSTALLATION INSTRUCTIONS

A pressure regulator sized for this unit is included. The gas line connecting to the range must be 3/4" or larger. If flexible connectors are used, the inside diameter must be 3/4" or larger. An adequate ventilation system is required for commercial cooking equipment. Information may be obtained by writing to the National Fire Protection Association, 1 Batterymarch Park, Quincy, MA 02269, www.NFPA.org. When writing, refer to NFPA No. 96.4. These units are manufactured for installation in accordance with ANSZ223.1A (latest edition), National Fuel Gas Code. Copies may be obtained from The American Gas Association, 400 N Capitol St. NW, Washington, DC 20001, www.AGA.org.

Venancio continuously improves the design of its products, therefore reserves the right to change specifications at any time without prior notice. Such revisions do not entitle the buyer to corresponding changes, improvements, additions or replacements for previously purchased equipment.

Rev. 04 01/2023

Salamander Broiler