

OASIS®

USER MANUAL

PN 54423

SELF-SERVICE MULTI-PURPOSE REFRIGERATED ISLAND DISPLAY CASES
> Note: See Next Page For List of Models To Which This Manual Applies

Important!
See Page 13
For Product And
Signage Placement
Guidelines!

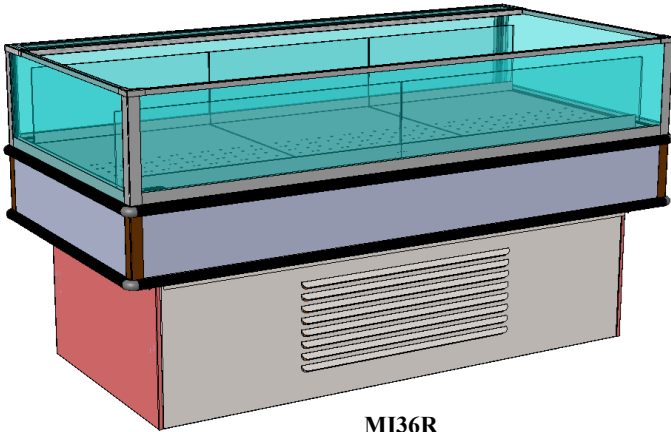

MI36R

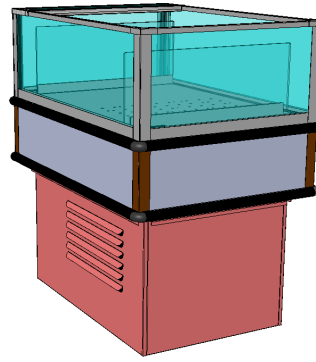

MI32R

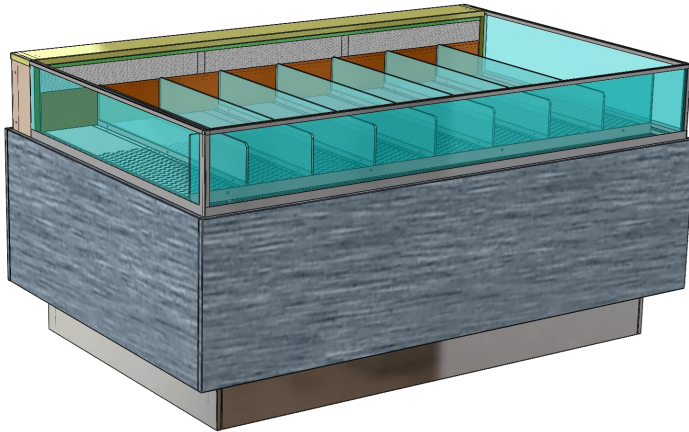

MI6R.7065 / Honeycomb / Adjustable Dividers /
Removable Exterior Panels

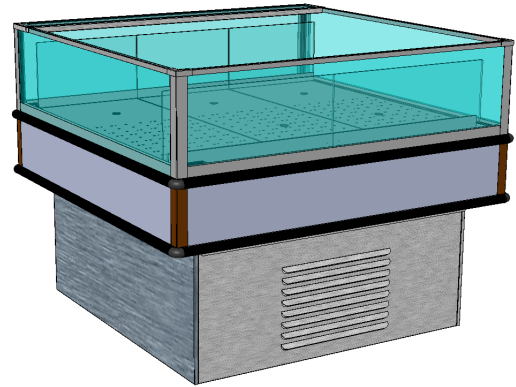

MI44R

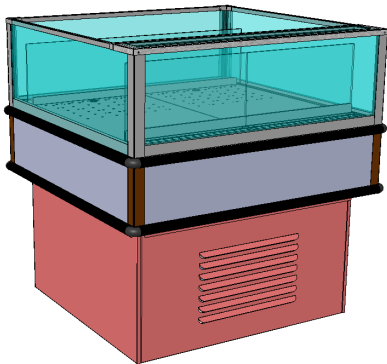

MI33R

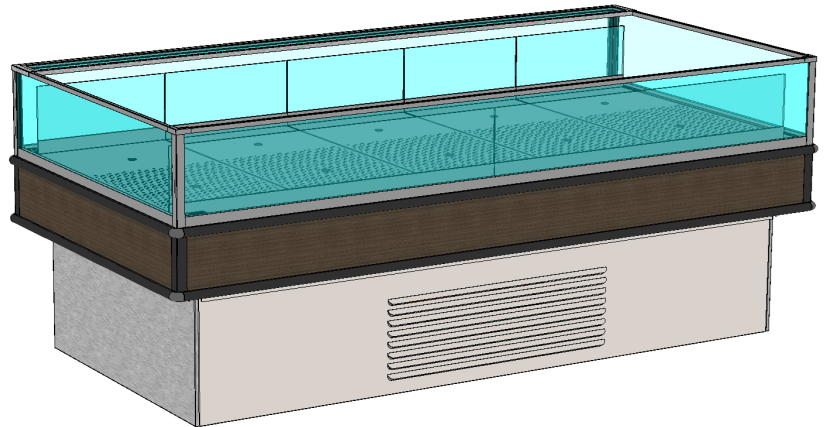

MI48R / Removable Exterior Panels /
No Acrylic Airflow Risers or Dividers

Structural Concepts®

DELIVERING FRESH. ALWAYS.™ Structural Concepts Corp. · 888 E. Porter Rd · Muskegon, MI 49441 Phone: 231.798.8888 Fax: 231.798.4960 · www.structuralconcepts.com

TABLE OF CONTENTS

OVERVIEW / TYPE / COMPLIANCE / WARNINGS / PRECAUTIONS / WIRING / PLUGS	3-4
CASE REMOVAL FROM SKID (LOCKING/UNLOCKING CASTERS)	5
EXTERIOR PANEL ATTACHMENT (AFTER REMOVAL FROM SKID AND PROPERLY POSITIONED)	6
POSITIONING-LEVELING UNIT / START-UP / TEMPERATURE CONTROL / 41 °F & 38 °F SWITCH	7
ADJUSTABLE ACRYLIC DIVIDERS / FIXED ACRYLIC DIVIDERS / HORIZONTAL GLASS FIXTURES	8
HONEYCOMB AIR DIFFUSER - MODEL MI6R.6620, MI6R.7065, ET AL.	9
EVAPORATOR SECTION ACCESS: BAFFLED DECK PAN ASSEMBLIES / THERMOMETER	10
EVAPORATOR SECTION ACCESS, CONT'D: LOWER DECK PAN REMOVAL / EVAPORATOR SECTION COMPONENTS	11
LOAD LIMIT (LOAD LINE) GUIDELINES / CASE FRONT & REAR DESIGNATIONS / THERMOMETER	12
PRODUCT AND SIGNAGE PLACEMENT GUIDELINES	13
REFRIGERATION FUNDAMENTALS - REFRIGERATION. PACKAGE / TEMPERATURE CONTROLLER / EVAPORATOR PAN ACCESS	14
CONDENSER PACKAGE EXPLODED PICTORIAL - WITH SMALL HOT GAS LOOP CONDENSATE UNIT	15-16
CONDENSER PACKAGE EXPLODED PICTORIAL - WITH LARGE HOT GAS LOOP CONDENSATE UNIT	17
CLEANING SCHEDULE	18
PREVENTIVE MAINTENANCE (PERFORMED BY TRAINED SERVICE PROVIDER)	19
TROUBLESHOOTING (GENERAL)	20-21
TROUBLESHOOTING - CONDENSING SYSTEM (QUALIFIED SERVICE TECHNICIANS)	22
TROUBLESHOOTING - EVAPORATOR SYSTEM (QUALIFIED SERVICE TECHNICIANS)	23
SERIAL LABEL LOCATION & INFORMATION LISTED / TECH INFO & SERVICE	24
PROGRAMMABLE CONTROLLER INFORMATION.....	25
TECHNICAL SERVICE CONTACT INFORMATION / WARRANTY INFORMATION	26

This Operating Manual Applies To The Following Models*:

MI3R.5429, MI3R.6212B, MI36R, MI5R, MI6R, MI6R.6212C, MI6R.6620, MI6R.7065, MI8R,
MI8R.6212A, MI32R, MI33R, MI36R, MI44R, MI44R.7523, MI45R, MI46R, MI48R & MI48R.7788

*Note: Manual May Also Apply To Additional Models Not Listed Herein.

OVERVIEW

- Unless specified differently, these Structural Concepts merchandisers are designed to merchandise packaged products at 41 °F (5 °C) or less product temperatures.
- **Note: On certain cases, a switch is provided to allow temperatures to be either 41 °F (for produce and prepackaged product) or 38 °F (for red meat).**
- Model MI6R.6620 (and/or other similar units) is designed to merchandise beverages at 28 °F (2 °C) or less product temperatures.
- Cases should be installed and operated according to this operating manual's instructions to insure proper performance. Improper use will void warranty.

TYPE I vs. TYPE II ENVIRONMENTAL CONDITIONS

This unit is designed for the display of products in ambient store conditions where temperature and humidity are maintained within a specific range.

- Type I display refrigerators are intended for use in an area where environmental conditions are controlled and maintained so that the ambient temperature does not exceed 75 °F (24 °C) and 55% maximum humidity.
- Type II display refrigerators are intended for use in an

area where environmental conditions are controlled and maintained so that the ambient temperature does not exceed 80 °F (27 °C) and 55% maximum humidity.

- If unsure if Type I or II, see tag near serial label on case.

COMPLIANCE

- Performance issues when in violation of applicable NEC, federal, state and local electrical and plumbing codes are not covered by warranty. See below.

WARNINGS

- This sheet contains important warnings to prevent injury or death. Please read carefully!

REFRIGERANT DISCLOSURE STATEMENT

- This equipment is prohibited from use in California with any refrigerants on the "List of Prohibited Substances" for that specific end-use, in accordance with California Code of Regulations, title 17, section 95374.
- This disclosure statement has been reviewed and approved by Structural Concepts and Structural Concepts attests, under penalty of perjury, that these statements are true and accurate."



COMPLIANCE
This equipment **MUST** be installed in compliance with all applicable NEC, federal, state and local electrical and plumbing codes.



WARNING
Risk of electric shock. Disconnect power before servicing unit.
CAUTION! More than one source of electrical supply is employed with units that have separate circuits.
Disconnect ALL ELECTRICAL SOURCES before servicing.



WARNING
Hazardous moving parts. Do not operate unit with covers removed.
Fan blades may be exposed when deck panel is removed.
Disconnect power before removing deck panel.



WARNING
Condensate Pan is Hot!
Disconnect and allow to cool before cleaning or removing from case.



WARNING: This product can expose you to chemicals, including Urethane (Ethyl Carbamate), which are known to the state of California to cause cancer and birth defects or other reproductive harm. For more information go to P65Warnings.ca.gov.

PRECAUTIONS

- This sheet contains important precautions to prevent damage to unit or merchandise.
- Please read carefully!
- See previous page for specifics on **OVERVIEW**, **TYPE**, **COMPLIANCE** and **WARNINGS**.

WIRING DIAGRAM

- Each case has its own wiring diagram folded and in its own packet.
- Wiring diagram placement may vary; it may be placed near ballast box, field wiring box, raceway cover, or other related location.

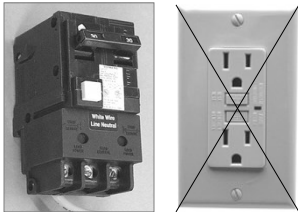

CAUTION! GFCI BREAKER USE REQUIREMENT
 If N.E.C. (National Electric Code) or your local code requires GFCI (Ground Fault Circuit Interrupter) protection, you **MUST** use a GFCI breaker in lieu of a GFCI receptacle.



CAUTION! POWER CORD AND PLUG MAINTENANCE
 Risk of electric shock. If cord or plug becomes damaged, replace only with cord and plug of same type.

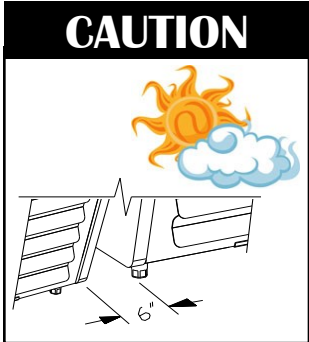

CAUTION! ADVERSE CONDITIONS / SPACING ISSUES

- Performance issues caused by adverse conditions are **NOT** warranted.
- Keep end panels tightly joined or at least 6" away from structures to prevent condensation. Keep rear panel at least 6" from wall/structure.
- Unit must be kept at least 15-feet from exterior doors, overhead HVAC vents or any air curtain disruption to maintain proper temperatures.
- Unit must not be exposed to direct sunlight or any heat source.
- Self-contained unit clearance: 6" min. air intake / 6" min. air discharge.



CAUTION! DO NOT RELY ON THERMOMETERS OR THERMOSTATS FOR PRODUCT (FOOD) TEMPERATURES.

- Thermometers & thermostats reflect air temperatures **ONLY**.
- For **ACTUAL** product (food) temperatures, use a calibrated food probe thermometers **ONLY**.
- For accurate readings, **DO NOT** use infrared food thermometers.

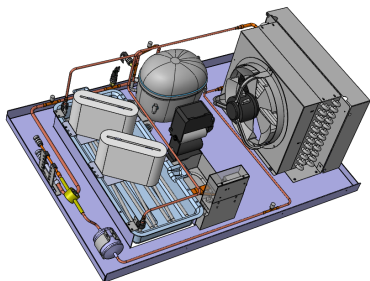

CAUTION! CHECK CONDENSATE PAN, ITS POSITION & PLUG!
 Water on flooring can cause extensive damage!

- Before powering up case, check that condensate pan is positioned directly under case's condensate drain.
- Before powering up case, check that condensate pan's electrical plug is **SECURELY** connected to condensate system's receptacle.
- If wicking material is used in condensate pan, check that it is secure.

CASE REMOVAL FROM SKID (LOCKING/UNLOCKING CASTERS)

1. Removing Case Shipping Brackets That Are Attached To Skid

- Remove screws holding shipping brackets to skid.
- Remove shipping brackets from skid.
- See illustrations below. Note: Shipping Brackets will vary in size, shape, material and location depending upon case type and model.

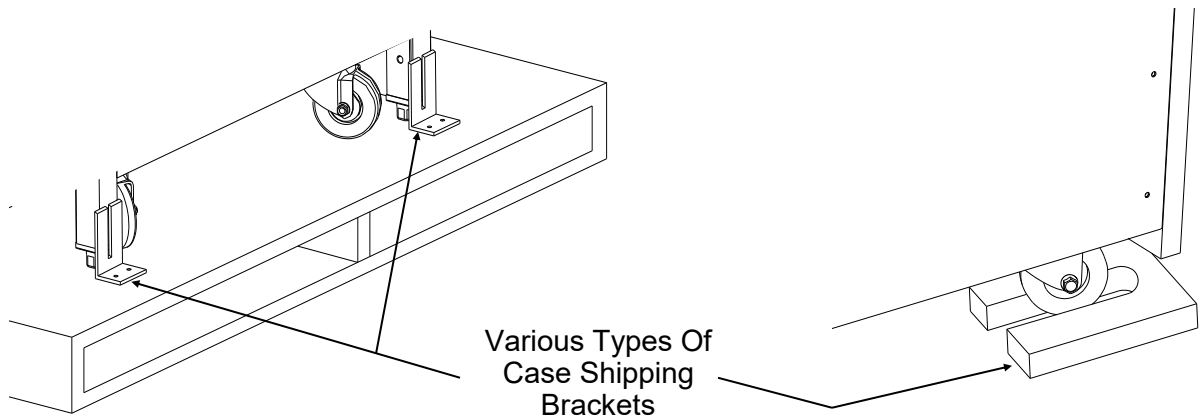

2. Remove Case (With Casters) From Skid

- A. Place ramp up against skid (to allow case to smoothly slide off from skid).
- B. Maintain support of case at all times or center of gravity may cause case to fall.
- C. Unlock Casters. Slide unit to rear of skid. Slide down ramp and off from skid.

Note: See next page for panel attachment instructions.

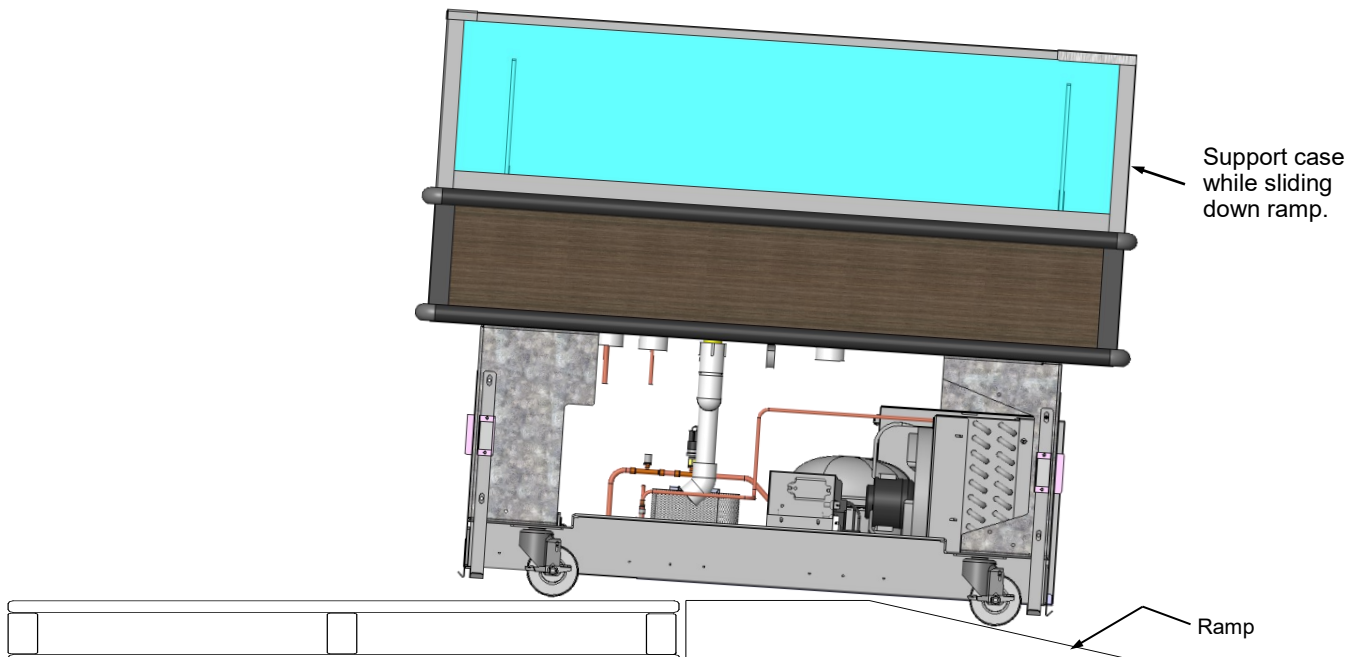

EXTERIOR PANEL ATTACHMENT (AFTER REMOVAL FROM SKID AND PROPERLY POSITIONED)

Exterior Panel Attachment (Both Grille and Solid)

- Attach to case after case has been removed and properly positioned/located in store.
- All four (4) exterior panels may be removed without tools.
- Lift exterior panel up and off tabs.
- Separate lower panel from magnets
- See illustrations below.

Note: Illustrations Shown May Not Reflect Every Feature Or Option Of Your Particular Case.

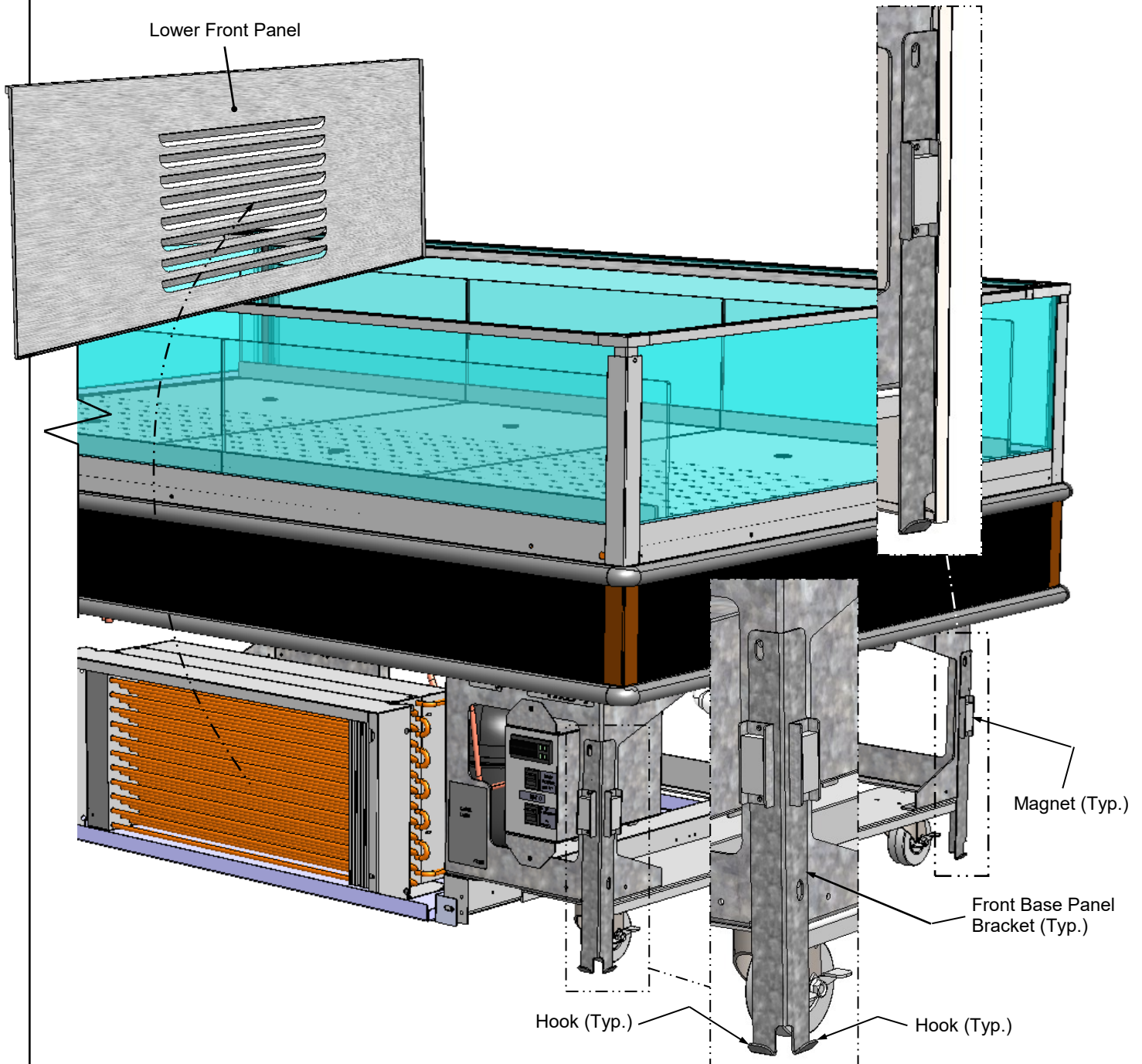

1. Position and Level Unit

- Position unit. Remove either controls side or opposite side grille to access levelers (see below). Grilles may be simply lifted up and off.
- Level unit by either hand-cranking or using adjustable wrench (see below). Return grilles.

2. Display Case Start-Up

- Lift up controls cover on control side of unit (see illustrations below).
- Turn on main power switch.
- Main power switch will start evaporator coil fans, and the compressor motor.

3. Temperature Control Access

- Lift up controls cover on control side of unit.
- See the temperature controller section of this manual for instructions and details on proper temperature controller settings.

4. 41 °F / 38 °F Temperature Control Switch

- “O” (Open Position Switch Setting): Controller maintains the preset value for “Red Meat.”
- “I” (Closed Position Switch Setting): Controller modifies the set point, adding the value of the parameter (r4). For example, when ‘r4’ = 3 °F (as a preset value), switching to “I” (closed position) will INCREASE the setpoint by 3 °F for “Produce.”

- To raise or lower temperature set points BEYOND the preset values, see **PROGRAMMABLE CONTROLLER** section in manual.

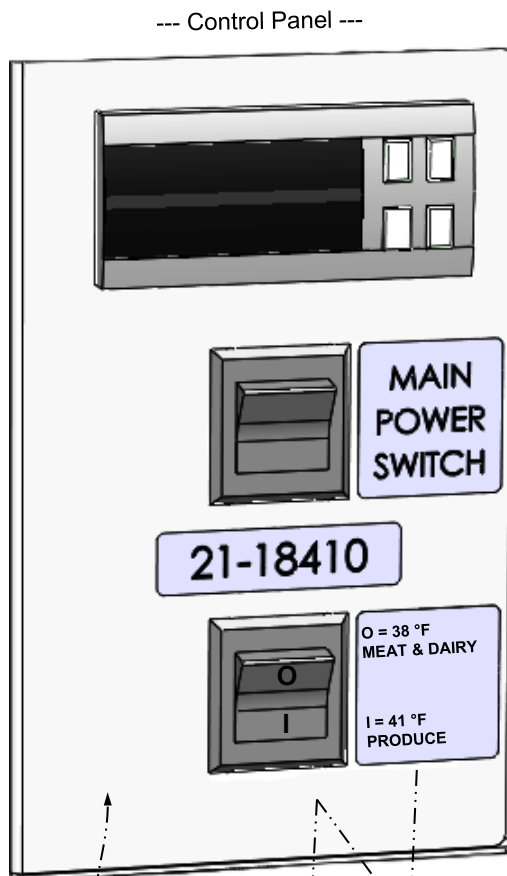
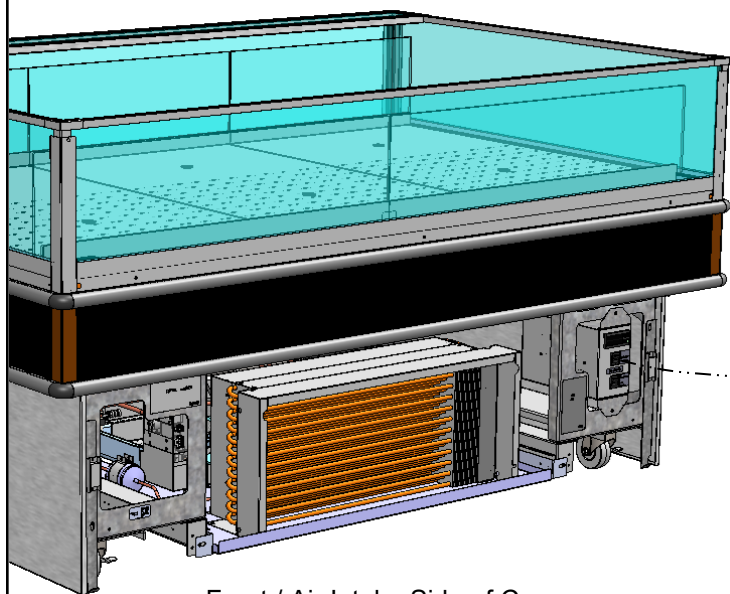

**O = 38 °F
MEAT & DAIRY**

**I = 41 °F
PRODUCE**

1. Adjustable Acrylic Dividers - Not All Models

- Certain merchandisers have adjustable dividers.
- Dividers are entirely removable and adjustable.
 - See illustration below-left.

2. Fixed Acrylic Dividers - Not All Models

- Certain merchandisers have fixed dividers.
- Dividers ARE NOT adjustable.
- See illustration below-right.

3. Horizontal Glass Fixtures

- Most merchandisers have horizontal glass fixtures OVER the air discharge grille.
- Glass fixture is NOT removable or adjustable.
- See illustration below-right.

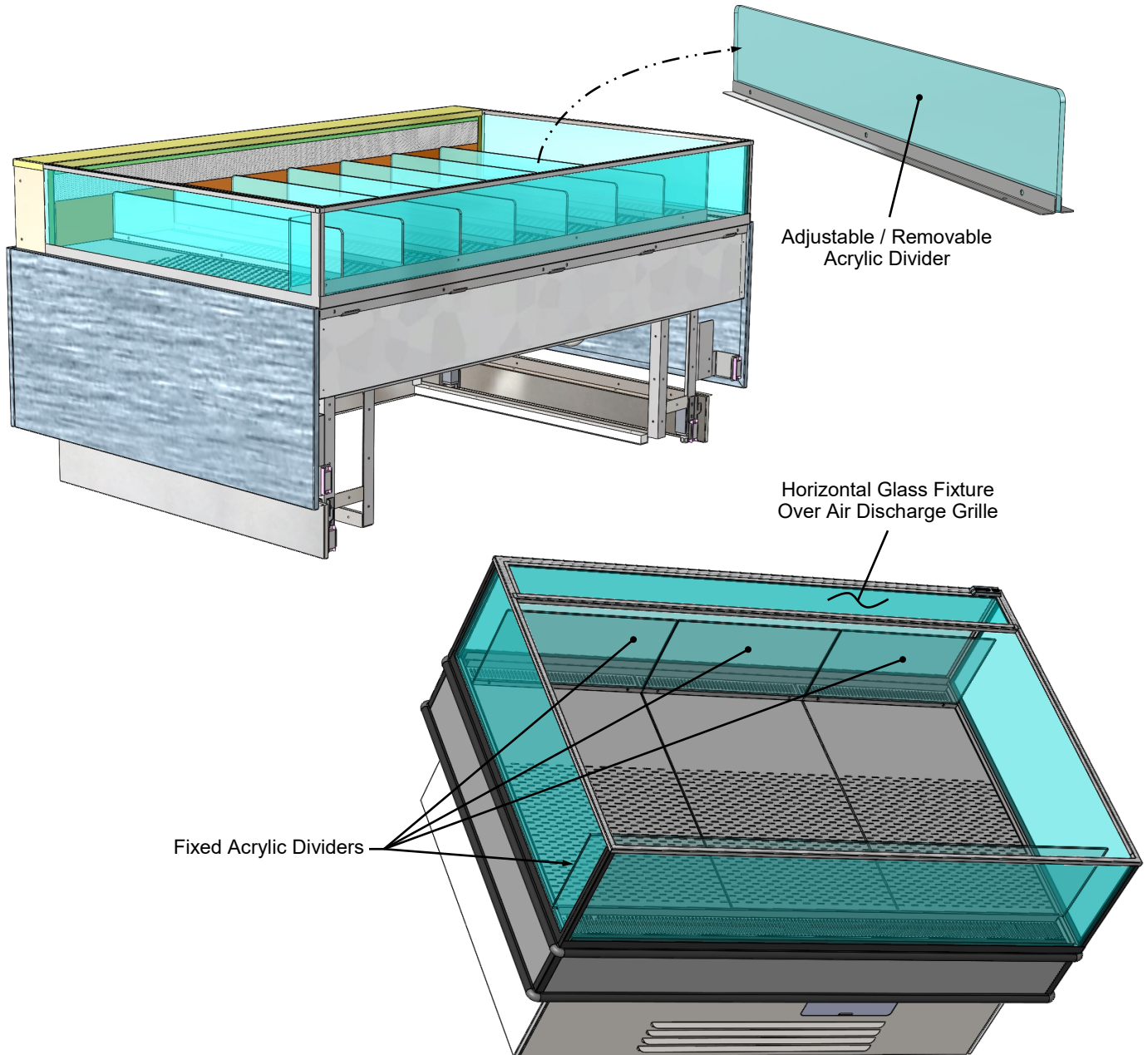

Note: Illustrations Shown May Not Reflect Every Feature Or Option Of Your Particular Case.

HONEYCOMB AIR DIFFUSER - MODEL MI6R.6620, MI6R.7065, ET AL.

Honeycomb Air Diffuser - Model MI6R.6620, MI6R.7065, Et Al.

- Honeycomb air diffuser is not on all models.
- Honeycomb can be removed for cleaning and/or maintenance.

Honeycomb Air Diffuser Removal / Replacement

- Honeycomb is located in discharge air duct.

- To remove the honeycomb from the back panel assembly, simply squeeze (“pinch”) together and lift out from housing.
- See **PREVENTIVE MAINTENANCE (TO BE PERFORMED BY TRAINED SERVICE PROVIDERS)** section in manual for cleaning specifics.
- After cleaning, be certain to replace honeycomb in same position so as not to disrupt airflow.

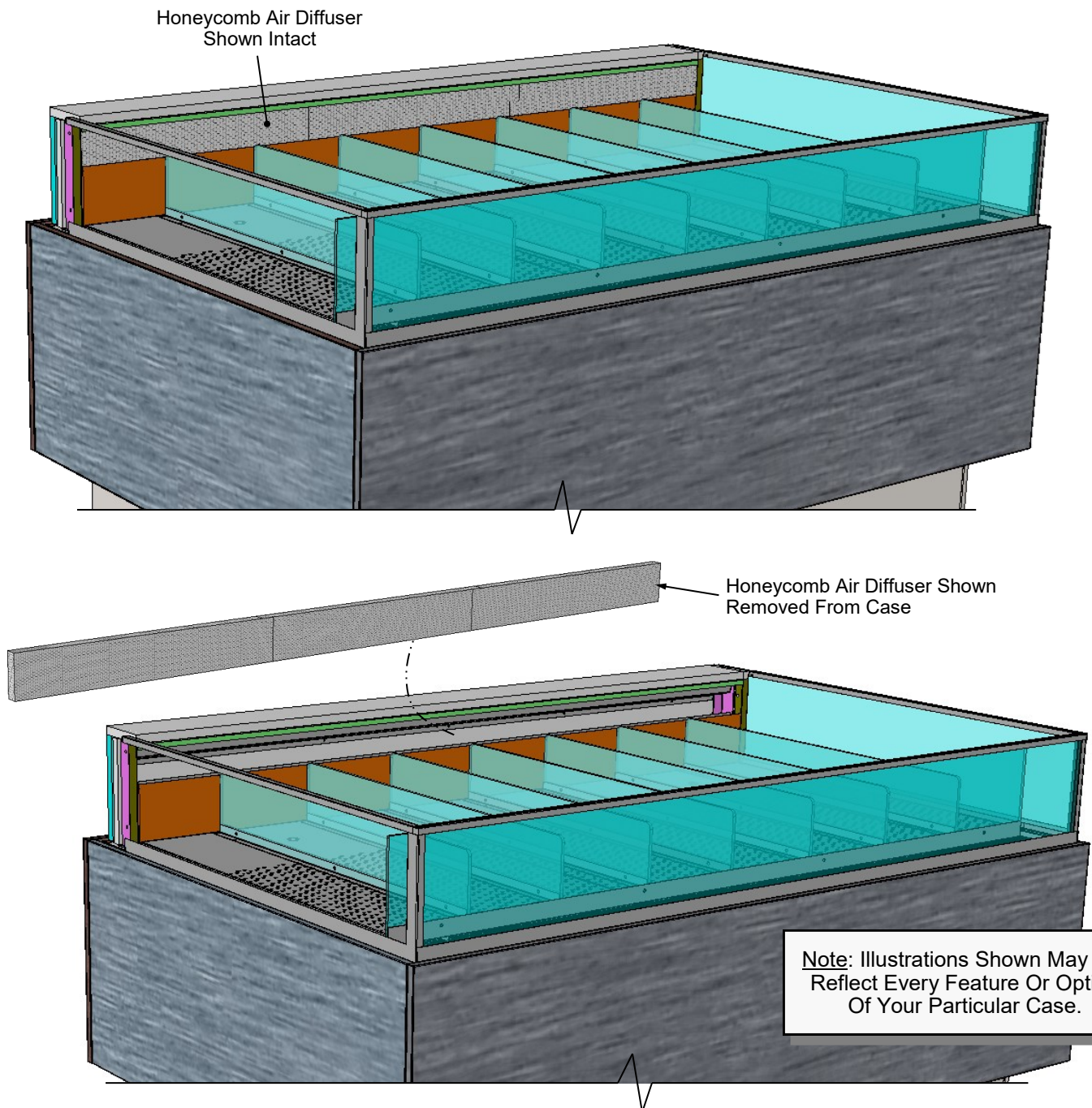

EVAPORATOR SECTION ACCESS: BAFFLED DECK PAN ASSEMBLIES / THERMOMETER

Caution! Turn Off Power To Unit Before Removing Deck Pans! Rotating Fans Can Cause Severe Injury!

Evaporator Section Access

1. Baffled Deck Pan Assemblies Removal

- Baffled deck pan assemblies consist of pan, acrylic product stop and finger hole inserts.
- To remove, lift pans at location nearest thermometer UP AND OVER acrylic product stop.
- Remove remaining baffled deck pan assemblies in like manner.
- See below illustration.

2. Thermometer

- Thermometer is located on air return duct (as illustrated below).
- Thermometer reflects internal air temperature only (not actual food temperature).
- Use probe thermometers to determine actual product temperatures.

Random Model Is Shown Below. It May Not Exactly Reflect Every Feature Or Option Of Your Particular Model.

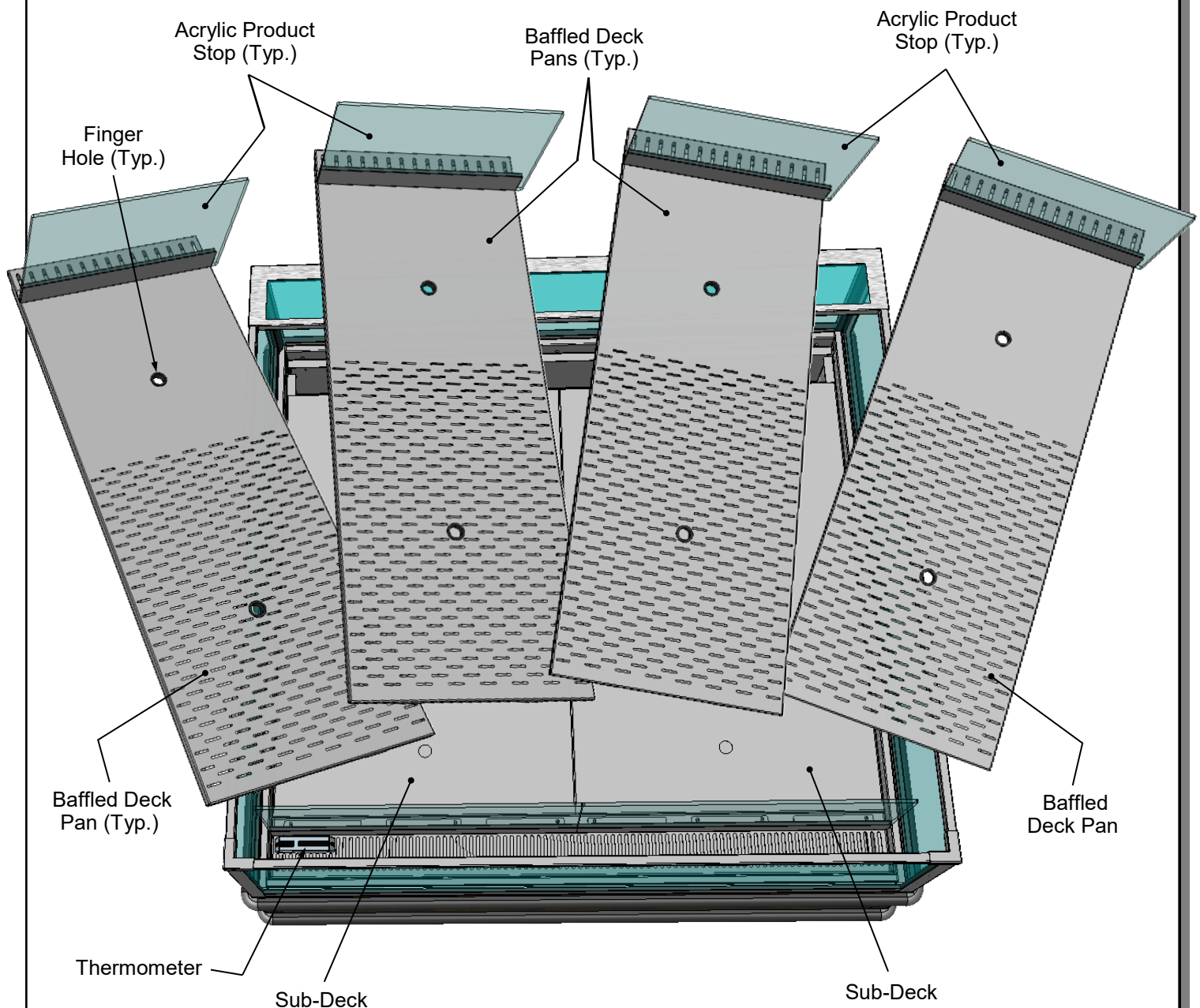

Caution! Turn Off Power To Unit Before Removing Deck Pans! Rotating Fans Can Cause Severe Injury!

Evaporator Section Access, Cont'd

3. Lower Deck Pan Removal

- After baffled deck pans have been removed, you must remove lower deck pans.
- Finger holes are provided for easy removal.
- Place in location away from foot traffic while cleaning or servicing unit.
- See illustration below.

4. Evaporator Section Components

- After lower deck pans have been removed, you may access TXV, drain, refrigeration lines, trough and drain (as illustrated below).
- Follow cleaning and/or servicing instructions for evaporator section components.
- After cleaning/servicing unit, return components in reverse order they were removed.

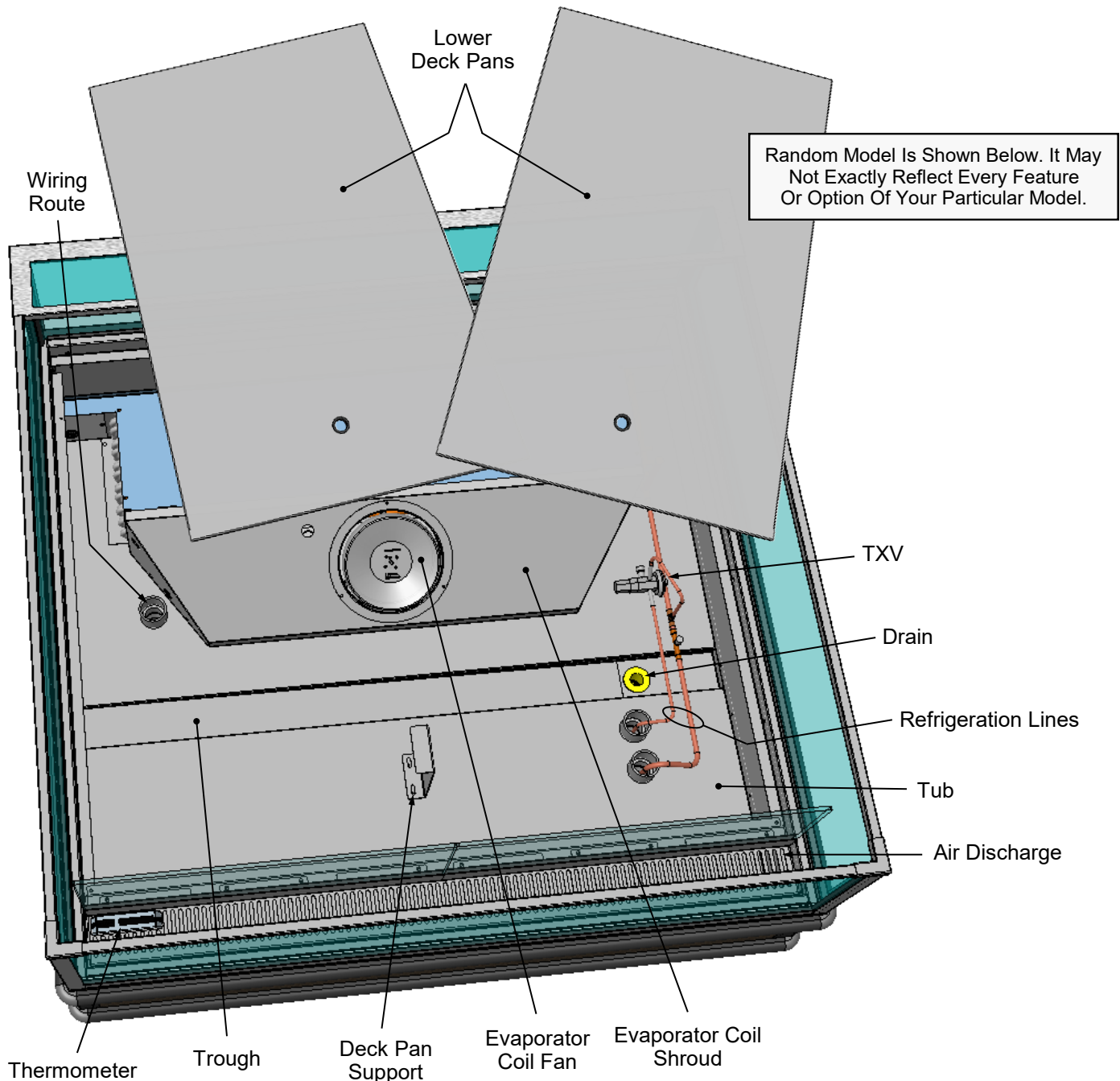

1. Load Limit (Load Line) Guidelines

Caution! Stacking food beyond the load line will prevent food from being at proper temperature.

- Load line is placed at location to allow proper refrigerated airflow to product.
- Load line will be etched in acrylic on both sides of case.
- NEVER set product on air return grille!
- See illustration below for load line locations.

2. Case Front & Rear Designations

- Case front is the controls side and air intake side of case. This is also the side of case that the condensing package is slid out for cleaning and/or servicing.
- Case rear is the air discharge side of case.
- See illustration below.

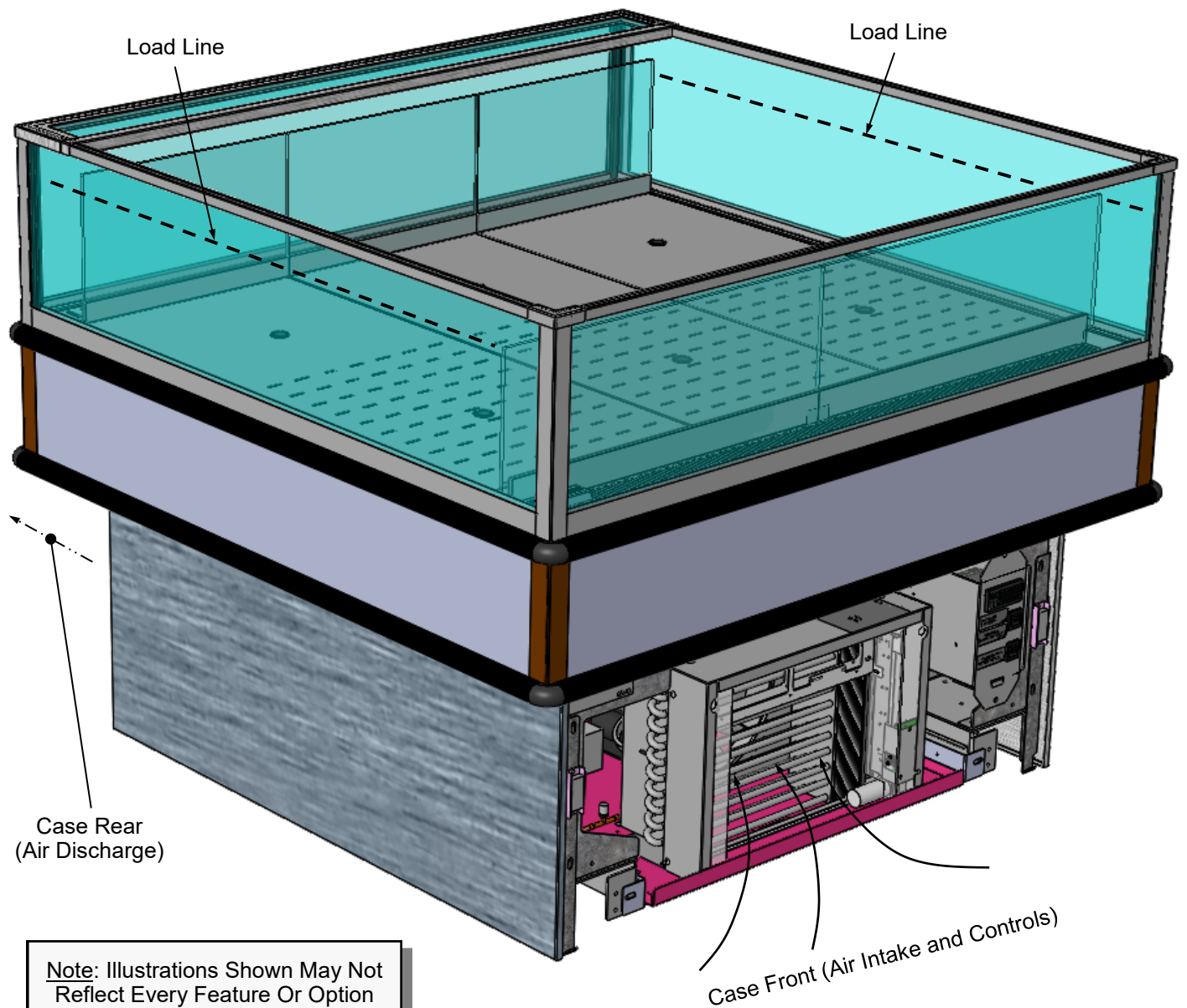

PRODUCT AND SIGNAGE PLACEMENT GUIDELINES

1. Product Placement Guidelines

- Higher protein products require the coolest air temperatures on a case.
- Area of case nearest air discharge remains coolest during regular operation.
- Place high protein products (such as poultry, sausage and other meats) closer to air discharge side of merchandiser.
- Place low protein products (such as produce, sauces and pastas) closer to air return side of merchandiser.

Cautionary Notes:

- > NEVER set product on air return grille.
- > Food in 'clamshell containers' must be placed at case rear to insure proper cooling of its product!

2. Signage Placement Guidelines

- Airflow perforations through decking help keep product at proper temperatures.
- DO NOT block airflow perforations on decking!

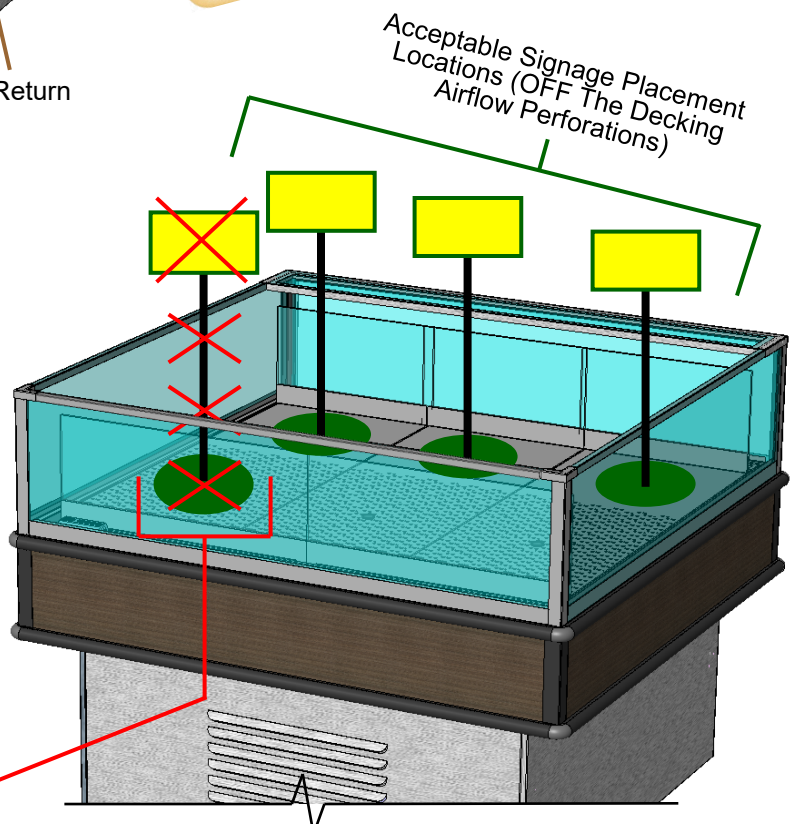
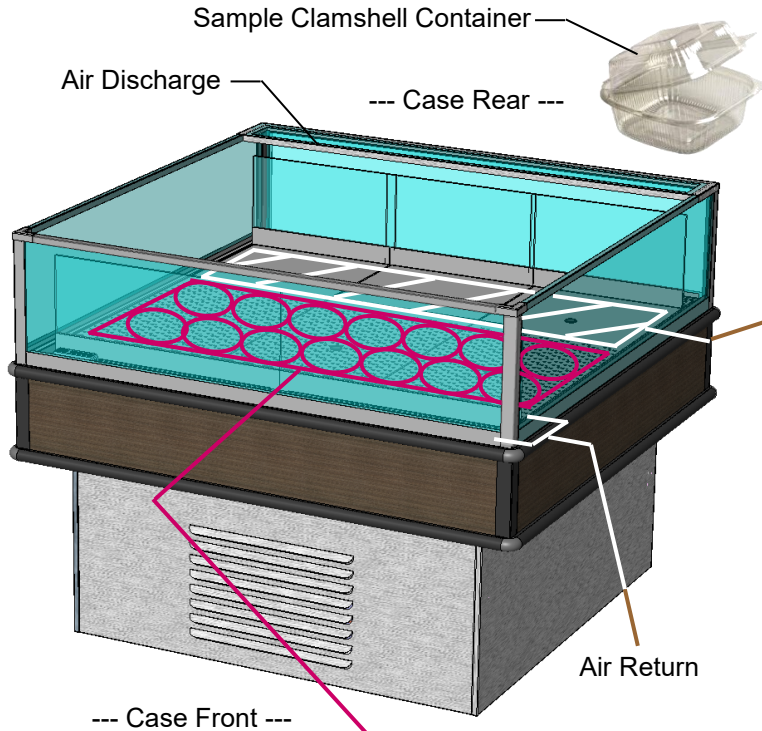

Unacceptable Signage Placement Location (On Decking Airflow Perforations)

1. Temp. Controller (Self-Contained Units Only)

- Temperature controller is located behind the front panel. See illustration at right.
- Temperature / Defrost control settings are programmable from this location.
- Case Temperature Set Point is set at the factory, as determined by case size & sensor probe location.
- Temperature is controlled by thermostat.
- If a temperature setting change is required, follow instructions regarding Temperature Control Programming Steps in the technical information section of this operating manual.
- If service is required to the temperature control unit, call Structural Concepts Corporation. Maintenance should be performed by a certified technician.
- The toll-free number is listed in the Technical Service section of this manual.
- See Temperature Controller section in this manual.

--- Control Panel ---

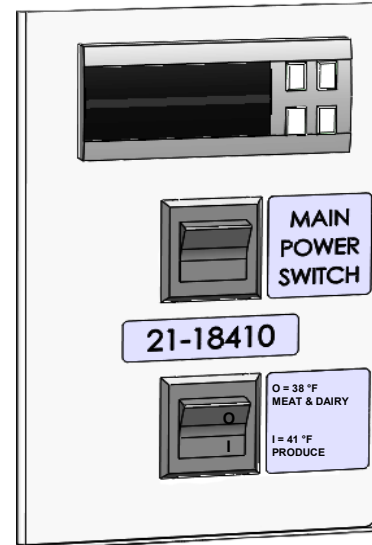

NOTE: Thermometers located in the refrigerated compartment are for monitoring warmest air temperature in accordance with NSF Std. 7

2. Refrigeration Package Access

Note: Servicing to be accomplished by licensed electrical / refrigeration contractor.

Pull Out Refrigeration Package

- Slide grille (located opposite to temperature controls) up and out. No tools are required.
- **Note:** At initial slide-out, it may be necessary to remove compressor pan shipment screws (see illustration at right for location).
- *Refrigerant lines are flexible to facilitate rear access maintenance.*
- Plastic glides are mounted at base to assist in sliding the condenser out for access.
- Slide condenser unit out 12 to 18 inches to access high pressure service connection.

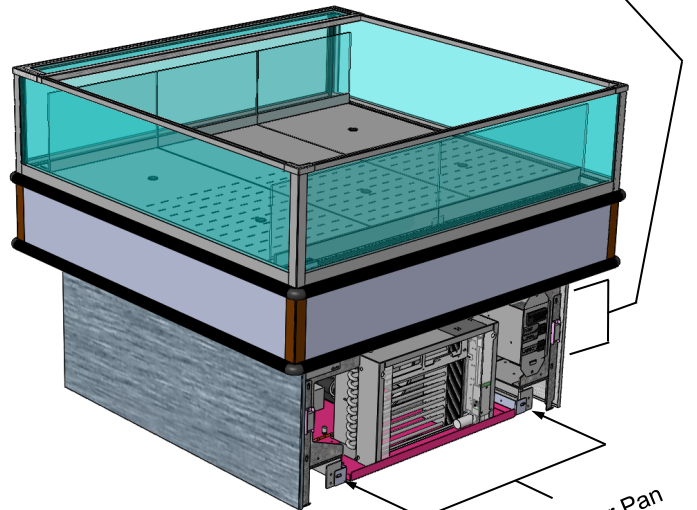

3. Evaporator Pan Access At Case Rear

- **Turn off main power switch; allow evaporator pan to cool.**
- Evaporator pan is generally accessible by sliding out condenser package from under case (as shown in mid-right illustration).
- However, by removing air intake grille, it is possible to access evaporator pan for cleaning.
- Replace rear intake grille to case when completed.
- See illustration at lower-right.

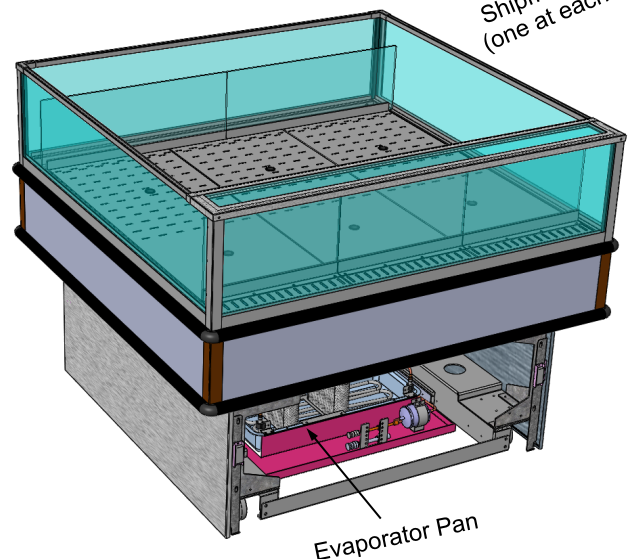

CONDENSER PACKAGE EXPLODED PICTORIAL - WITH SMALL HOT GAS LOOP CONDENSATE UNIT

Illustration Below May Not Reflect Every Feature Or Option Of Your Particular Case. See Previous Page AND Next Page For Alternate Condenser Package Designs.

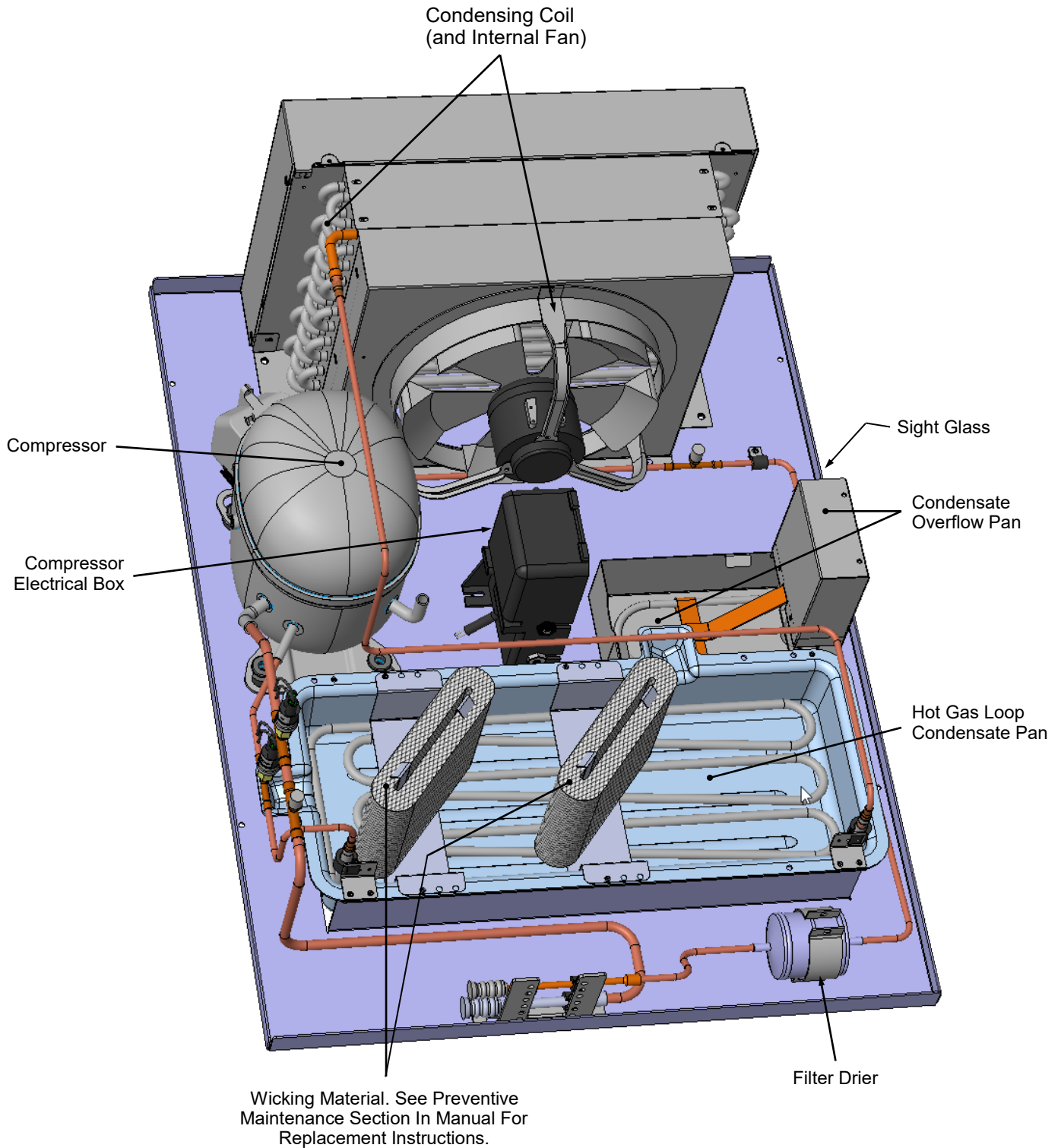

CONDENSER PACKAGE EXPLODED PICTORIAL - WITH SMALL HOT GAS LOOP CONDENSATE UNIT

Illustration Below May Not Reflect Every Feature Or Option Of Your Particular Case.
See Previous Page AND Next Page For Alternate Condenser Package Designs.

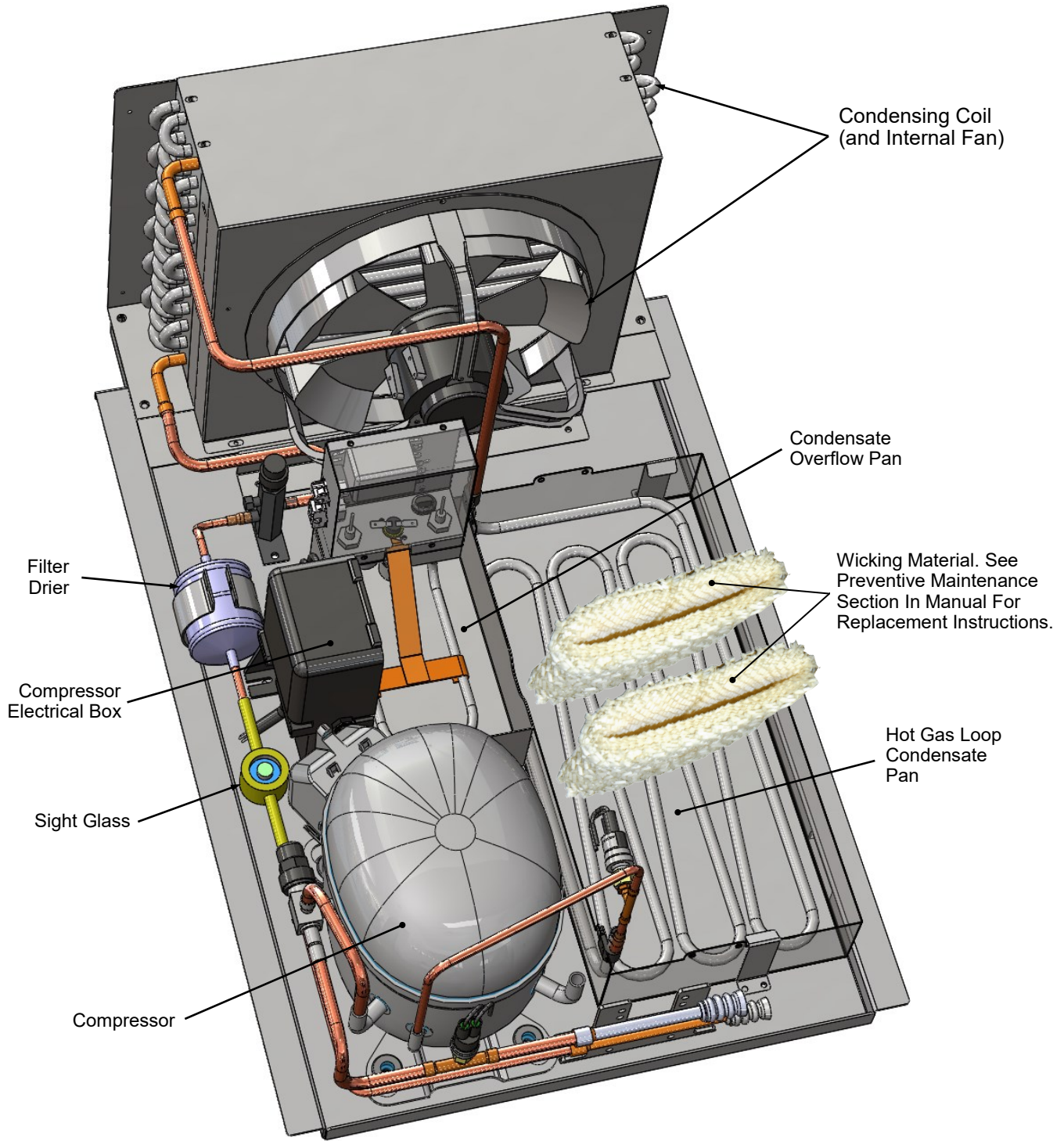

CONDENSER PACKAGE EXPLODED PICTORIAL - WITH LARGE HOT GAS LOOP CONDENSATE UNIT

Model MI8R.6212A Is Illustrated Below. It May Not Reflect Every Feature Or Option Of Your Particular Case. See Previous Pages For Alternate Condenser Package Designs.

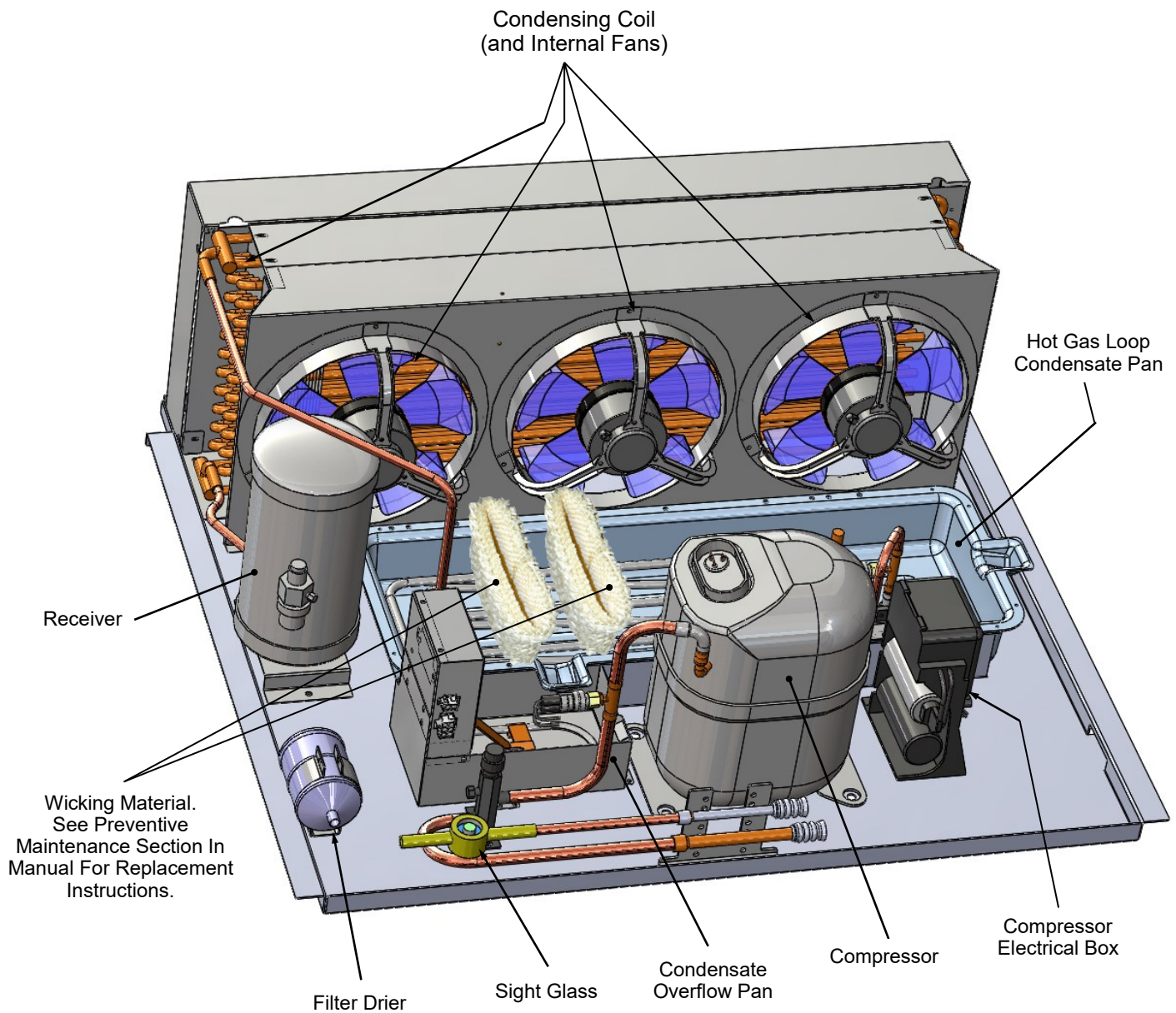

CLEANING SCHEDULE (“D” = Daily / “W” = Weekly / “M” = Monthly)

Area/ Component	D	W	M	Task
Clean Acrylic	X			<p>Acrylic MUST BE cleaned according to these instructions to prevent acrylic surfaces from becoming cloudy, dull or scratched.</p> <ul style="list-style-type: none"> • DO NOT use a dry cloth or paper towel to wipe off dust or debris (this can rub dirt and dust into the acrylic surface). • BEFORE cleaning, use air pressure or feather duster to blow or remove all dust and debris. • DO NOT use household cleaners (such as ammonia, bleach, Windex® or Formula 409®). • DO NOT use powder scouring cleansers (such as Comet® or Ajax®) or other abrasive cleansers on acrylic! • DO use a soft sponge or cloth with a mix of warm (not hot!) water and mild soap solution (such as Palmolive®, Joy®, Dawn®, or Ajax® dishwashing detergents) to wipe down surfaces. • DO use acrylic cleaning product such as Brillianize®, or Novus® #1 (if you want to purchase cleaners specifically formulated to clean acrylic). • DO rinse out the soft sponge or cloth often in the solution while cleaning the acrylic. This keeps the dust and debris from being collected in one area and relocated to another! • DO wipe dry with a microfiber cloth, microfiber terry cloth or chamois cloth to dry acrylic surfaces. • DO NOT wipe dry with a dry cloth or paper towel! • DO use products such as Novus® #2 to remove fine scratches, haziness and abrasions that can form in acrylic. Also, Pittman ALR® may be used to removed oxidation (cloudy or dull acrylic surfaces). • <u>Note:</u> Model MI6R.6620 adjustable acrylic dividers may be removed, submersed in warm, soapy water, rinsed, dried and returned to case.
Clean Case Interior	X			Shelves and decks can be cleaned with a warm soap and water solution.
		X		Remove the decks and clean with soap and water.
		X		Vacuum tub under deck. Clean with soap and water. Wipe dry with clean cloth.
		X		Keep drains clean and free of debris which could clog the drain and rob the case of needed refrigeration.
Clean Condensing Coil		X		Clean the condenser coil.
			X	Using air pressure if available, or an industrial strength vacuum, clean the dust and dirt that collects on the condenser coil. Be careful not to damage the fins on the coil.

PREVENTIVE MAINTENANCE (TO BE PERFORMED BY TRAINED SERVICE PROVIDER)

WARNING! TURN OFF CASE BEFORE PERFORMING PREVENTIVE MAINTENANCE!

Area of Case	FREQ.	INSTRUCTIONS
Case Exterior	Monthly	<p>Condensing Coil:</p> <ul style="list-style-type: none"> Remove panel to access area by lifting up and off (no screw removal is required; simply lift up and off) Use air pressure or industrial strength vacuum; clean dust and dirt that may collect on the condenser coil. Caution! Airborne dust can contaminating food! Use wet rags to cover area where air pressure is blowing. Warning! Coil fins are sharp. Handle with care! Return panel to case.
	Quarterly	<p>Condensate Package / Overflow Condensate Pan / Compressor Area: <i>Caution! Be certain to disconnect power from case before cleaning condensate package!</i></p> <ul style="list-style-type: none"> Slide/roll compressor package out from under case. Use a scrub-brush and a de-scaling solution such as CLR® (to prevent corrosion, lime and rust). Follow instructions as to proper dilution, safety precautions and scrubbing method. Electric heater coil condensate pans can be removed and cleaned. After thoroughly cleaning pan with scrub-brush and solution, rinse thoroughly with clean water (in spray bottle) and wipe dry with sponge or paper towel. Use moist cloth to wipe off dust & debris that collects on various parts (fans, sight glass, overflow pan, etc.). Slide refrigeration assembly back under case. Replace lower panel via hook/magnet method (no screws required). Check if wicking material is dirty, worn, tattered or disintegrating. If so, it must be replaced. Contact Structural Concepts for replacement wicking material (toll-free number is listed on the last page of this operating manual).
	Quarterly	<p>Under Case Cleaning: Once condenser package is clear of unit, vacuum under case to remove dust and dirt that collects under case.</p>
Case Interior	Quarterly	<p>Tube, Coil, Drain, Fan Blade, Motor, Bracket: <i>Disconnect power from the case before cleaning tub, coil, fan, motor and drain area!</i></p> <ul style="list-style-type: none"> Remove decking, sub-deck and fan shroud. Use vacuum to clean evaporator coils. Clean tub, coil and drain with warm water, clean cloth, brush and mild soap solution. Remove any debris that may clog drain. Clean fan blade, motor and bracket by wiping down with moist cloth.
	Quarterly	<p>Honeycomb Air Diffusers:</p> <ul style="list-style-type: none"> Remove honeycomb air diffuser from case. Vacuum. Clean with warm water and soap. Return to case. See HONEYCOMB AIR DIFFUSER - MODEL MI6R.6620, MI6R.7065, ET AL. in manual for removal/replacement illustrations.

TROUBLESHOOTING (GENERAL)

CONDITION	TROUBLESHOOTING
Water Is On The Floor	Check that the drain trap is free of debris.
	Check that the drain hose is correctly positioned over evaporator pan (or floor drain, for remote units).
	Check store conditions. To prevent condensation in Type 1 environments, maximum conditions are to be 55% humidity / 75 °F. For Type 2 units, maximum conditions are to be 55% humidity / 80° F. See serial label (at case rear near main power switch) for your case type.
	Check evaporator pan float for proper operation.
	Check that evaporator pan is plugged in.
	WICKING MATERIAL MAY BE DIRTY, WORN, TATTERED OR DISINTEGRATING. <ul style="list-style-type: none"> • If so, wicking material must be replaced. • Contact Structural Concepts for replacement wicking material (toll-free number is listed on the last page of this operating manual).
	EVAPORATOR PAN AND/OR OVERFLOW EVAPORATOR PAN MAY BE MALFUNCTIONING. If so, water will overflow pan and seep onto flooring causing damage! Until evaporator pan is functioning (or is replaced), the following procedures are recommended: <ul style="list-style-type: none"> • Use wet-dry vacuum (or mop & bucket) to remove standing water. • Use 'catch pans' for water to drain into. Swap out regularly until case has completely drained.
Fan Emits Excessive Noise	DISRUPTION OF POWER CAN CAUSE WATER TO OVERFLOW PAN AND SEEP ONTO FLOORING CAUSING DAMAGE! Check that power to case is constant. Until power is restored, following these procedures: <ul style="list-style-type: none"> • Use wet-dry vacuum (or mop & bucket) to remove standing water. • Use 'catch pans' for water to drain into. Swap out regularly until evaporation of case is complete (or until power is restored). • When power to case is restored, evaporator pan should function properly and water will no longer overflow onto flooring.
	Check that the case is aligned, level and plumb.
	Check evaporator fan for cleanliness.
	Unplug fan motor; check motor shaft for excessive bearing wear.
	Check that fan motor is securely mounted in brackets.
	Verify that fan blade is securely mounted to fan motor.
	Check that nothing is preventing blade rotation.
Check that the fan shroud is properly secured.	
Fans Are Not Working	Check that the MAIN power switch (if present) is on.
	Check that fans are plugged in to fan shroud.
	Check for foreign material obstructing fan performance.
	Check that fan blade freely rotates within fan shroud.

TROUBLESHOOTING, GENERAL - CONTINUED

CONDITION	TROUBLESHOOTING
Fan Is Not Working, Continued	Check that power is going to fan
	Check that fan wiring is connected on terminal blocks.
System Is Not Operating	Check that the utility power is on.
	Check the circuit breaker box for tripped circuits.
Case Is Not Holding Temperature	If a large amount of warm product was added to the case, it will take time for the temperature to adjust. Product should be pre-chilled before placing in display case.
	Check Temperature Controller section in this manual.
	Check that the case is not in the sun or near a heat or air conditioning vent.
	If case is located near outside doors, temperature fluctuation can hinder unit's ability to maintain temperature.
	Check air grilles for obstructions. Maintain airflow clearance of 6" (minimum) to 12" (recommended) at case front and rear.
	Check sight glass for flashing and/or low charge.
	Check set point Temperature; it may be adjusted too high.
Control Display Is Flashing	Check Temperature Controller section in this manual.
Condensing Unit Is Not Operating (Self-Contained Units Only)	Check Temperature Controller section in this manual.
	Check that the power is turned on.
	Review Temperature Controller's Settings for accuracy.

TROUBLESHOOTING - CONDENSING SYSTEM (BY TRAINED SERVICE PROVIDERS ONLY)

CONDITION	TROUBLESHOOTING
Head Pressure Too High	Check that the condensing coil is not dirty or covered.
	Check that condensing fans are working.
	Check that refrigerant is not overcharged.
	Perform sub-cooling check and verify that no contaminants are in system.
	Check that liquid line filter dryer is not plugged.
	Check that close-offs are intact (around condensing coil) and that air is not recirculating.
	Check that store ambient temperature isn't above maximum allowed. See OVERVIEW / TYPE / COMPLIANCE / WARNINGS / PRECAUTIONS / WIRING / PLUGS section in this manual.
Head Pressure Too Low	Check if sight glass is flashing or showing low charge.
	Check that suction pressure isn't too low.
	Check that compressor reed valves aren't bad. Look for high suction/low head pressure. Perform pump-down.

TROUBLESHOOTING - EVAPORATOR SYSTEM (BY TRAINED SERVICE PROVIDERS ONLY)

CONDITION	TROUBLESHOOTING
Low Suction Pressure	Check if sight glass is flashing or showing low charge.
	Check that expansion valve (TXV) isn't restricted. Check element charge.
	Check that liquid line or filter isn't restricted. Check that refrigeration lines and/or hoses are not kinked on either high or low sides.
	Check that evaporator fan motors are working.
	Check that superheat is between 6 °F to 8 °F.
	Check that there is no air recirculation around evaporator coil.
	Check that evaporator coil is not iced up.
High Suction Pressure	Check for refrigerant overcharge.
	Check that compressor reed valves aren't bad. Look for high suction/low head pressure. Perform pump down.
	Check that the "cooling load" isn't high. Product must be pre-chilled before placing in refrigerated section of case.
	Check that case is at least <u>15-feet</u> from exterior doors, overhead HVAC vents or any air curtain disruption.
	Check that unit is not exposed to direct sunlight via windows or any other heat source (ovens, fryers, etc.).
	Check that superheat adjustment isn't low.
	Check TXV bulb installation <ul style="list-style-type: none"> a. Poor thermal contact. b. Warm location.

Serial Label Location & Information Listed / Technical Information & Service

- Serial labels are affixed at a wide range of places (on the header, near thermostat, at case rear, behind panels/toe-kicks, on electrical boxes, etc.).
- Serial labels contain electrical, temperature and refrigeration information, as well as regulatory standards to which the case conforms.

- Sample serial label shown below.
- For additional technical information and service, see the *TECHNICAL SERVICE* page in this manual for instructions on contacting Structural Concepts' Technical Service Department.

Structural Concepts®
888 E. Porter Rd - Muskegon, MI 49441

Oasis

MODEL NRS3648RXV-SAMPLE
SERIAL NO. 12345X30DZ098765



Intertek



Intertek

SAMPLE ONLY

3048256
Conforms to UL Std. 471
Conforms to NSF/ANSI Stds. 2 & 7
CERTIFIED TO CAN/CSA
STD C22.2 NO 120

Super Heat Temp
Defrost

SAMPLE ONLY

ELECTRICAL RATING
REFRIGERANT
DESIGN PRESSURE
MINIMUM CIRCUIT AMPACITY
MAXIMUM OVERCURRENT

6-8 °F
6 defrosts per day, 45 °F

SAMPLE ONLY

120/1/60 16 A
R513A AMOUNT 50 OZ
HIGH 186 LOW 88
20A
20A

FOR PARTS AND SERVICE
CALL 1-800-433-9490

SAMPLE ONLY

TYPE II DISPLAY REFRIGERATOR: THIS EQUIPMENT IS INTENDED FOR USE IN AN AREA WHERE THE ENVIRONMENTAL CONDITIONS ARE CONTROLLED AND MAINTAINED SUCH THAT THE AMBIENT TEMPERATURE DOES NOT EXCEED 80 °F (27 °C).

SAMPLE ONLY

SCAN FOR PRODUCT LITERATURE

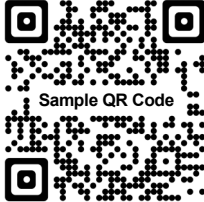

Sample QR Code

--- Sample Serial Label For Refrigerated Cases ---



Determine Which Programmable Controller Is On Your Case (Controllers That Are Commonly Used By Structural Concepts Are Shown Below). Your Particular Programmable Controller May Differ.



Carel® PJEZ Platform



Carel® ir33 Platform



Carel® iJF Platform



Dixell® XM670K-XM679K Platform

To Access Information About The Programmable Controller That Is Used On Your Case, Follow These Instructions:

- > If Viewing This Document on Smart Phone, Tablet or Computer, Select/Click On The QR Code at Right.
- > If Viewing This Document In Print (Hard Copy), Scan The QR Code at Right With Your Smart Phone or Tablet.

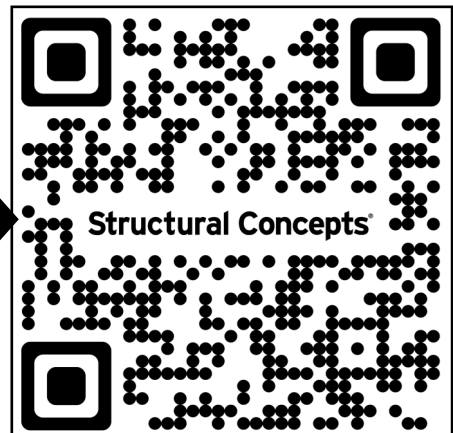
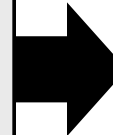

STRUCTURAL CONCEPTS TECHNICAL SERVICE CONTACT INFORMATION & LIMITED WARRANTY

TECH SERVICE/WARRANTY CONTACT INFO:

1 (800) 433-9490 / EXTENSION 1

DAYS/HOURS AVAILABLE:

**MONDAY - FRIDAY (CLOSED HOLIDAYS)
8:00 a.m. TO 5:00 p.m. EST**

**YOU MUST HAVE THE FOLLOWING INFO AVAILABLE
BEFORE CONTACTING STRUCTURAL CONCEPTS:**

**SERIAL NO. / MODEL NO. / STORE NO. / STORE
ADDRESS / DETAILS (PHOTOS, LEAK LOCATIONS,
DAMAGE, STORE'S AMBIENT CONDITIONS, ETC.)**

**To Access The Limited Warranty To Your
Case, Follow These Instructions:**

**> If Viewing This Document on Smart Phone,
Tablet or Computer, Select/Click On The QR
Code at Right.**

**> If Viewing This Document In Print (Hard
Copy), Scan The QR Code at Right With Your
Smart Phone or Tablet.**

