



Your Solutions Partner

# Specifications

F.O.B. Sedalia, Missouri 65301



613Q-G3

### OPTIONS:

- Stainless steel interior
- 27" stainless steel angular legs
- Stainless steel back enclosure panel
- Seismic feet
- Field stacking kit
- Common gas manifold
- 48" flexible disconnect, w/restraining device
- Down draft hood
- Flu deflector
- Casters
- Extra deep oven racks
- Prison package - tamper proof screws, lexan hinged cover with lockable clasp
- Extended warranty

### Approval Stamp(s):

#### PRODUCT INFORMATION:

PROJECT: \_\_\_\_\_

ITEM: \_\_\_\_\_

QUANTITY: \_\_\_\_\_

MODEL:

### Duke Convection Ovens - "Q" Series Single Deck - Deep Depth - Gas

- **613Q-G3** Single deck, deep depth

#### STANDARD FEATURES

- 6 racks/13 rack positions
- Porcelain interior finish
- 50/50 stainless steel independent doors
- Doublepane glass both doors
- 27" angular painted/adjustable legs
- 2 Speed motor

#### OVEN SECTION

- Stainless steel front, sides and top
- 1 1/2" insulation on bottom, sides and back
- 3" insulation on top
- Interior lights

#### BURNER SYSTEM

- 40,000 BTU
- High output atmospheric burner system
- Main gas shut off valve
- Bult-in gas regulator

#### OVEN CONTROLS

- "V" - Basic snap action thermostat (200°-500°F), 60 minute electric dial timer with continuous sound buzzer, 2-speed fan
- "XX" - Solid state digital time and temperature controls, 12-hour countdown timer, **Cook and Hold** feature, 2-speed fan, Pulse fan capability

DUKE MANUFACTURING CO.  
 2305 N. Broadway  
 St. Louis, MO 63102  
 800.735.3853 Toll Free  
 314.231.5074 Fax  
 www.dukemfg.com  
 SS-1080 613Q-G3 Single-Deep-Gas

Specification subject to change

 **WARNING** For CA residents: go to [www.dukemfg.com/prop65](http://www.dukemfg.com/prop65) for prop 65 warning

Certifications



# DUKE CONVECTION OVENS

## "Q" SERIES

### SINGLE DECK - GAS - DEEP DEPTH

A.I.A. File No. 35-C-13

Catalog No. DCO-QGASDD

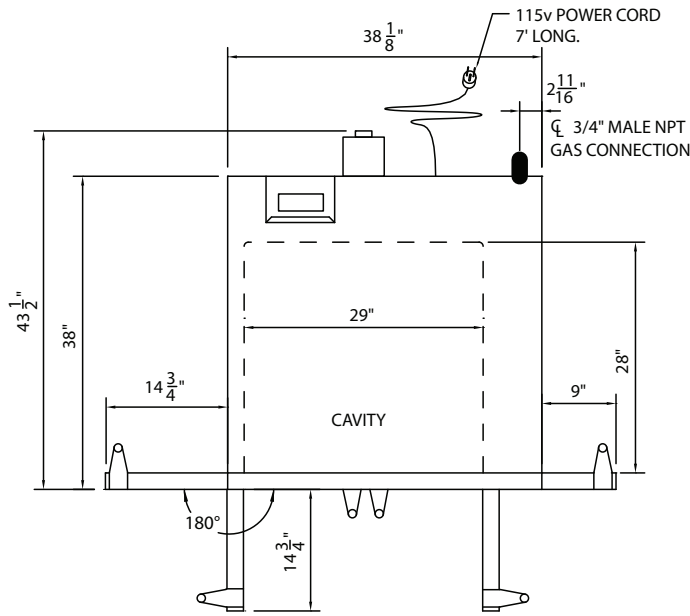

**TOP VIEW**

Gas Specifications		
<b>613Q-G3</b>	<b>BTU/Hour</b>	46,000
Regulated gas pressure required 3.5"WC natural /10" WC propane		
Combustible surface clearance - 1" side, 1" rear, 6" floor		
● Gas connection		
3/4" Gas connection		
Electrical requirements: 3.5 Amps/ 115V		
Standard 115V units supplied with 5' cord and plug		

Specify gas type  
Specify altitude over 2000 feet

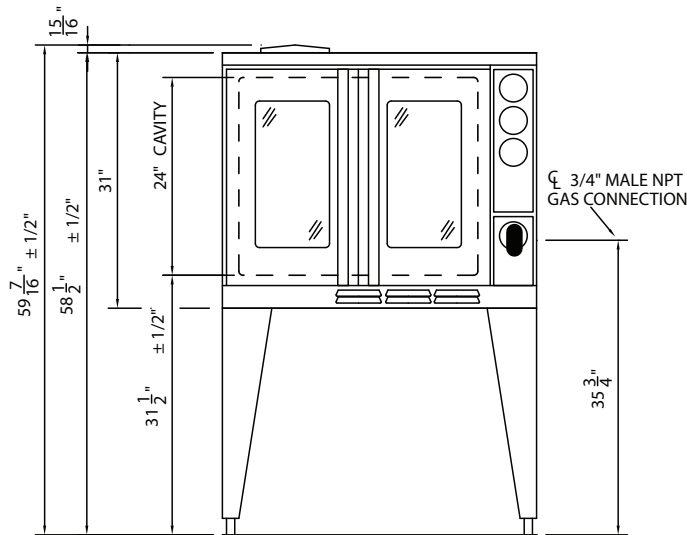

**FRONT VIEW**

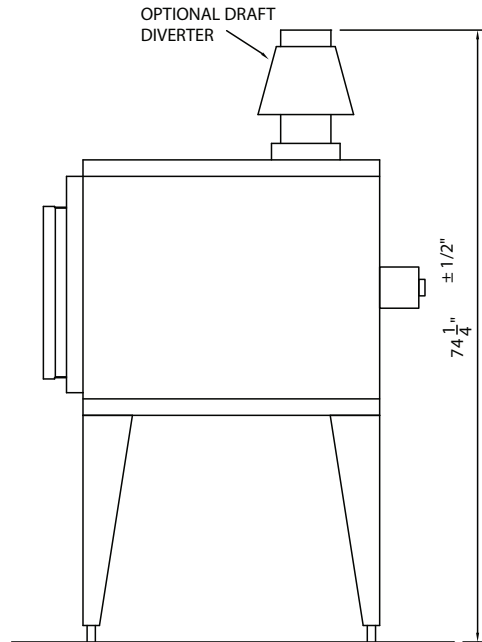

**RIGHT SIDE VIEW**

**DIMENSIONS:**

**Freight Class: 85**

Model	Height		Width		Depth		Cube ft. crated	Weight	
	in.	cm	in.	cm	in.	cm		lbs.	kg
<b>613Q-G3</b>	43.5	110.5	38	96.5	60.	152.4	65.4	540	245.5

DUKE CONVECTION OVENS - "Q" SERIES - SINGLE - DEEP DEPTH - GAS



**Duke Manufacturing Co.**  
2305 N. Broadway  
St. Louis, MO 63102

Phone: 314-231-1130  
Toll Free: 1-800-735-3853  
Fax: 314-231-5074

[www.dukemfg.com](http://www.dukemfg.com)