

# TURBOJET II CHILL TANK

Project \_\_\_\_\_  
 Item \_\_\_\_\_  
 Quantity \_\_\_\_\_  
 FCSI Section 11400 \_\_\_\_\_  
 Approved \_\_\_\_\_  
 Date \_\_\_\_\_

## Models

- HBC075



Model shown HBC75

## Standard Features

- Rated capacities for 75 gallons or up to 675 lbs. of product
- Solid state controls mounted in stainless steel 4X rated enclosures
- Heavy duty stainless steel tank, type 304 construction with adjustable legs
- Rounded internal tank corners for efficient cooling and easy cleaning
- Fully insulated tank with heavy duty stainless steel removable panels
- Automatic water fill and water level controls with over flow protection
- Built-in 5 Hp circulating pump for optimum rapid cooling.
- High efficiency shell and tube heat-exchanger for faster product cooling
- All plumbing connection supplied with line strainers
- Heavy duty stainless steel gas spring assisted lockable cover.
- Accepted for use in U.S.D.A. Inspected Facilities
- NSF/ANSI Standard 169 approved

## Short Form Specifications

Shall be Cleveland Model HBC075 Chill Tank, rated capacity of up to 675 lbs., fully insulated, Stainless steel tank and circulation pump for optimum water distribution, Solid state controls enclosed in UL rated, Stainless steel type NEMA 4X enclosure with automatic adjustable temperature control, Lockable gas spring assist cover, Direct expansion refrigerant in-line heat exchanger for efficient cooling.

## Options & Accessories

- Basket set and dolly
- Hoists for loading and unloading product baskets
- Air Power Vacuum Clipper
- Remote mounted 8 Hp Air-cooled condensing unit
- Remote mounted 8 Hp water cooled condensing unit
- Digital Time/Temperature Recorder with USB Port (DDR)

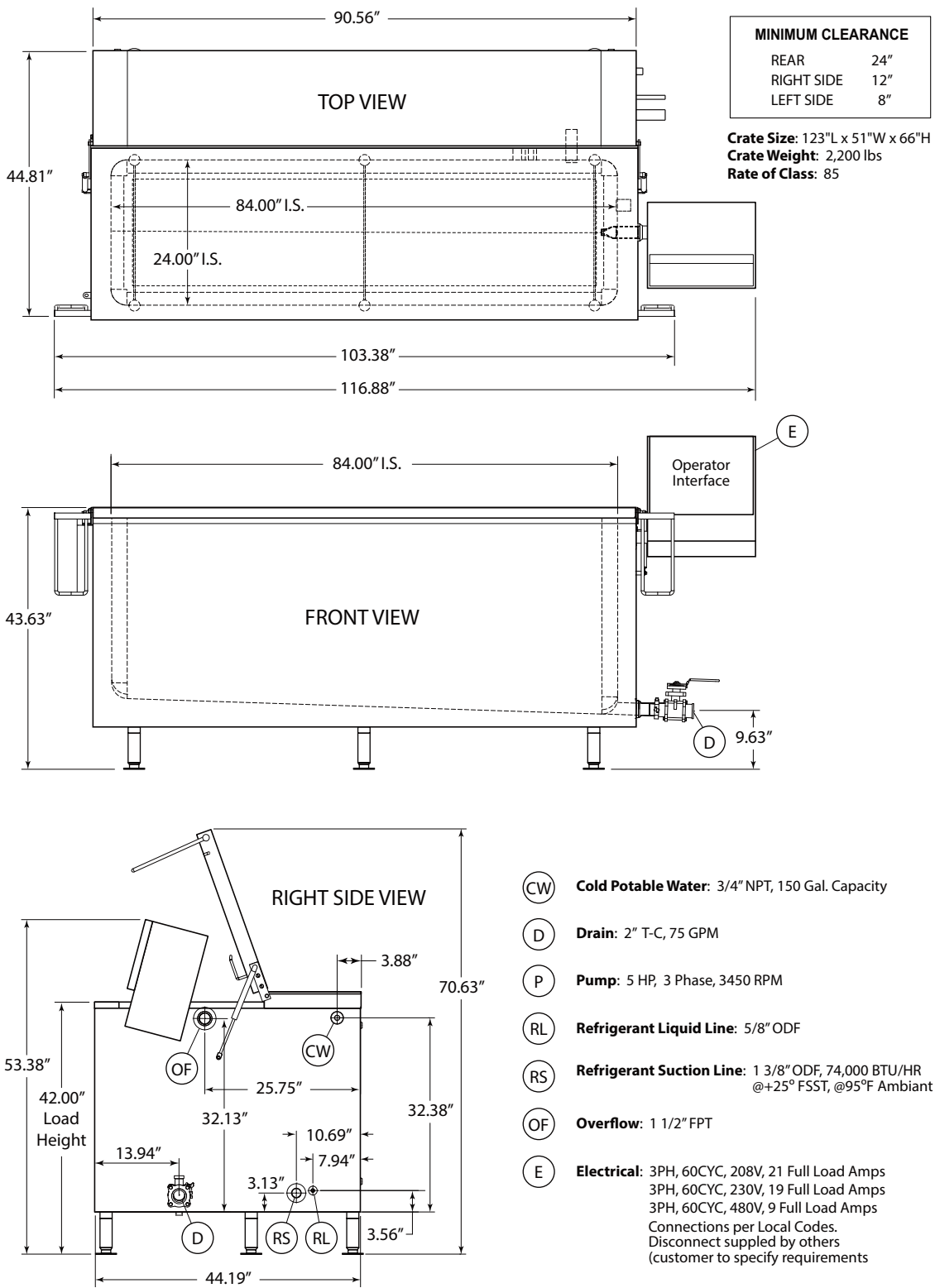

Cleveland Range reserves right of design improvement or modification, as warranted.

(NOT TO SCALE)