

"EBHS6" ENCLOSED BASE WORK TABLES

16GA Stainless Steel Top - Hinged Doors

FEATURES:

- 16GA Stainless Steel Flat Top
- Hinged Door Style
- Type 300 Stainless Steel With #4 Polish, Satin Finish
- Top Is Sound Deadened
- Reinforced With 1"x2" Channel Running Entire Length Of Table
- 1-1/2" Stallion Edge On Front And Rear With Side Edges 90 Degree Bend Down For Table Line-Up
- Stainless Steel Base And Undershelf
- Undershelf Is Secured In A Fixed Position, 10" Above Floor
- Shipped Standard Welded Set-Up

SPECIFICATIONS:

- Top: Stainless Steel Tops Are TIG Welded, Exposed Welds Are Polished To Match Adjacent Surface
- Top: 16GA Stainless Steel Type 300 Stainless Steel With #4 Polish, Satin Finish
- Shelf: 18GA Type 300 Stainless Steel, #4 Polish With Satin Finish
- Legs: 1-1/2" Square O.D., 16GA Tubular Stainless Steel
- Panels: 20GA Type 300 Stainless Steel, #4 Polish With Satin Finish
- Feet: 1" Adjustable Stainless Steel Bullet Feet



EBHS6-3072

CERTIFICATIONS:



ACCESSORIES

MODEL	DESCRIPTION
EBWS	Welded Intermediate Shelf - All Sizes

"EBHS6" ENCLOSED BASE WORK TABLES

LENGTH	# OF LEGS	24" WIDTH	WEIGHT (LBS)	30" WIDTH	WEIGHT (LBS)
36"	4	EBHS6-2436	175	EBHS6-3036	185
48"	4	EBHS6-2448	202	EBHS6-3048	215
60"	4	EBHS6-2460	239	EBHS6-3060	250
72"	5	EBHS6-2472	247	EBHS6-3072	255
84"	6	EBHS6-2484	264	EBHS6-3084	275
96"	6	EBHS6-2496	280	EBHS6-3096	295
108"	6	EBHS6-24108	305	EBHS6-30108	320
120"	6	EBHS6-24120	330	EBHS6-30120	355
132"	6	EBHS6-24132	360	EBHS6-30132	375
144"	6	EBHS6-24144	405	EBHS6-30144	420

ALL DIMENSIONS ARE TYPICAL. TOLERANCE +/- .500". JOHN BOOS & CO. RESERVES THE RIGHT TO CHANGE SPECIFICATIONS WITHOUT NOTICE.

DETAILED SPECIFICATIONS

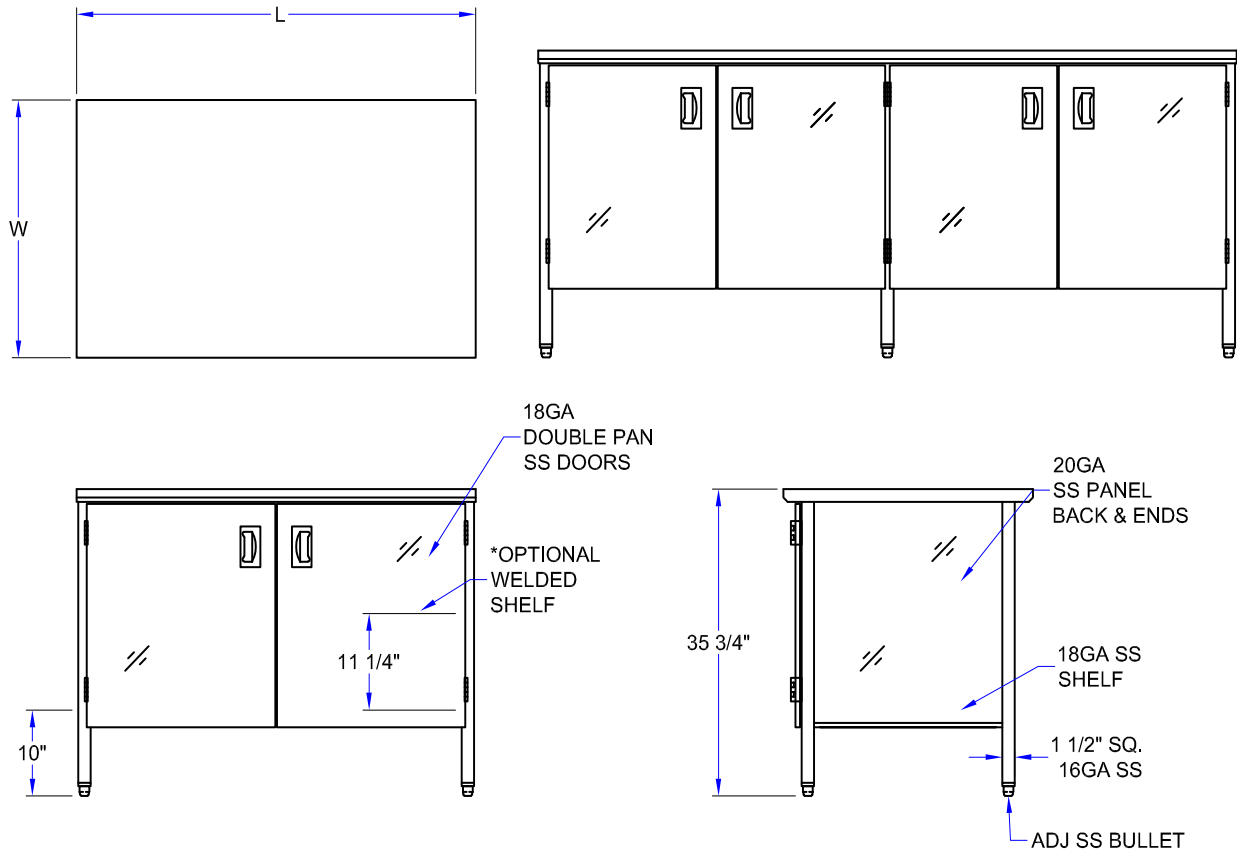

MODEL # STRUCTURE

S = Stainless Steel
 H = Hinged Doors
 EB = Enclosed Base

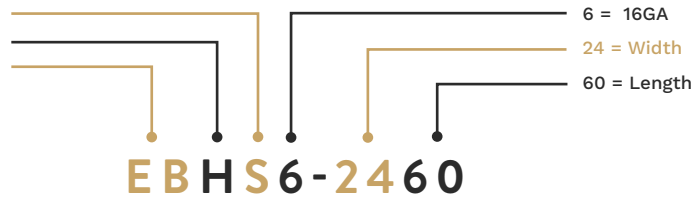

"EBHS6" ENCLOSED BASE WORK TABLES

LENGTH	# OF LEGS	24" WIDTH	WEIGHT (LBS)	30" WIDTH	WEIGHT (LBS)
36"	4	EBHS6-2436	175	EBHS6-3036	185
48"	4	EBHS6-2448	202	EBHS6-3048	215
60"	4	EBHS6-2460	239	EBHS6-3060	250
72"	5	EBHS6-2472	247	EBHS6-3072	255
84"	6	EBHS6-2484	264	EBHS6-3084	275
96"	6	EBHS6-2496	280	EBHS6-3096	295
108"	6	EBHS6-24108	305	EBHS6-30108	320
120"	6	EBHS6-24120	330	EBHS6-30120	355
132"	6	EBHS6-24132	360	EBHS6-30132	375
144"	6	EBHS6-24144	405	EBHS6-30144	420

ALL DIMENSIONS ARE TYPICAL. TOLERANCE +/- .500". JOHN BOOS & CO. RESERVES THE RIGHT TO CHANGE SPECIFICATIONS WITHOUT NOTICE.