

Front Load

Pass-Through

SW14

Performer Series Pot and Pan Washer

- Automatic door type warewasher with timed wash and rinse cycle
- 12 racks per hour. 14 pans per rack
- Timers are all adjustable
- Fully automatic operation with power on/off button
- Cycle starts when doors are closed
- Hold down rack system for secure washing
- Available in front load, corner load and pass-through operations

STANDARD FEATURES

- Wash tank heat: electric, gas, steam injection or steam coil
- Pressure regulator
- Single point electrical connection
- Low water cut-off
- Automatic fill
- Three position wash selector (complete cycle times): Light (260 seconds), Medium (380 seconds), Heavy (500 seconds)
- Emergency cycle stop button
- Wash pump pressure gauge
- Rinse pressure gauge
- Digital temperature controller for wash and rinse
- Pan washer clean-up hose and spray gun
- Lift-up door design
- Detergent connection provisions
- Pressure regulator to maintain 20 psi rinse flow
- SureFire® Start-Up & Check-Out Service

OPTIONS

- Stainless steel steam coil tank heat
- Steam booster
- Electric booster
- Security package
- Totally enclosed motor
- Recommended option: power vent fan



Additional Information

Capacity Per Hour	12 racks/168 sheet pans
Tank Capacity	40 gallons
Motor Size	10 hp (wash)
Electric Usage	Electric wash heat (1) 9kW element Rinse booster (1) 9 Kw element
Steam Consumption at 10-15 psi	23 lbs./hr. injected (wash tank) 43 lbs./hr. coil (wash tank)
Gas Consumption	48,000 BTUH 47 CFH natural gas 7" W.C. minute 19 CFH propane 11" W.C. minute
Final Rinse Peak Flow at 20 psi min.	5.0 gallons/minute
Final Rinse Consumption at 20 psi min.	65 gallons/hour 4.6 gallons/cycle
Exhaust Hood Requirement	6" steam exhaust vent
Peak Rate Drain Flow	5 gallons/minute
Shipping Weight	1175 lbs.

SPECIFICATIONS

CONSTRUCTION- Hood and tank constructed of 16 gauge series 300 S/S. Hood unit of all welded seamless construction. 12 gauge series 300 S/S frame, S/S legs and feet. All internal castings are non-corrosive bronze.

DOORS- Single front opening door. Operating door has fingertip control, balanced by an externally mounted counterweight. (Corner installations have two simultaneously opening doors at right angles.) Extra large die formed series 300 S/S doors ride in all S/S channels with easy-glide liners.

PUMP- Centrifugal type "packless" pump with a drain plug. Construction includes ceramic seal and a balanced cast impeller on a precision ground stainless steel shaft, extension or sleeve. All working parts mounted as an assembly and removable as a unit without disturbing the unit piping. One 10hp motor, standard horizontal C-face frame, drip proof, internally cooled with ball-bearing construction.

CONTROLS- Electro-mechanical controls, including motor controls and overload protection, transformer, contactors and all dishwasher integral controls.

SPRAY SYSTEM- Wash and rinse spray systems made of type 304 stainless steel tubing. The wash assembly arm is pinned into hub assembly. Upper and lower wash assemblies are removable without the use of tools. Rinse spray assemblies are removable with the use of simple tools.

WASH- 1 full width power spinning wash arm above and 1 full width power spinning wash arm below.

FINAL RINSE- Top and Bottom stationary final rinse nozzles. The nozzles produce a cone spray reducing water consumption, maximizing heat retention.

DRAIN- Drain valve externally controlled. Overflow assembly with skimmer cap is removable with the use of simple tools for drain line inspection. Heater is protected by low water level control.

EXHAUST- A 6-inch diameter exhaust vent companion flange is supplied on the top of the unit.

Contact Insinger Sales at 800-344-4802 for an installation drawing specific to your application.
This drawing is available on the Insinger webstie at www.insingermachine.com

Note: Due to product improvement we reserve the right to change information and specifications without notice.

Technical Drawings

Front Load

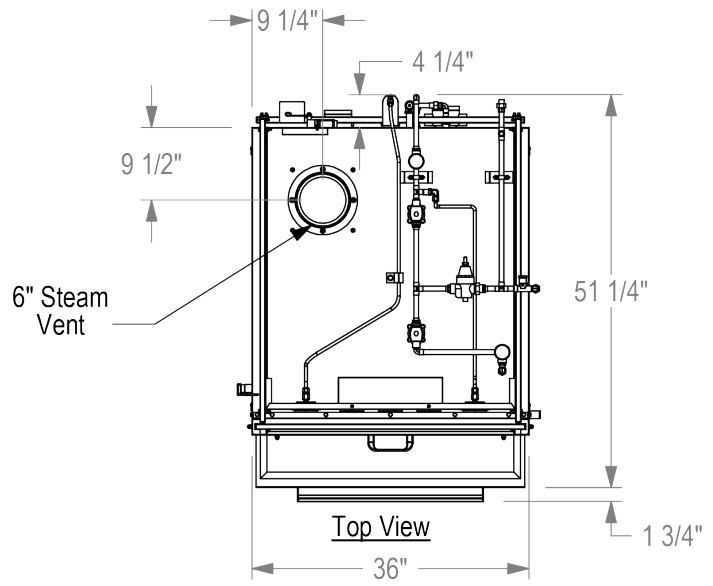
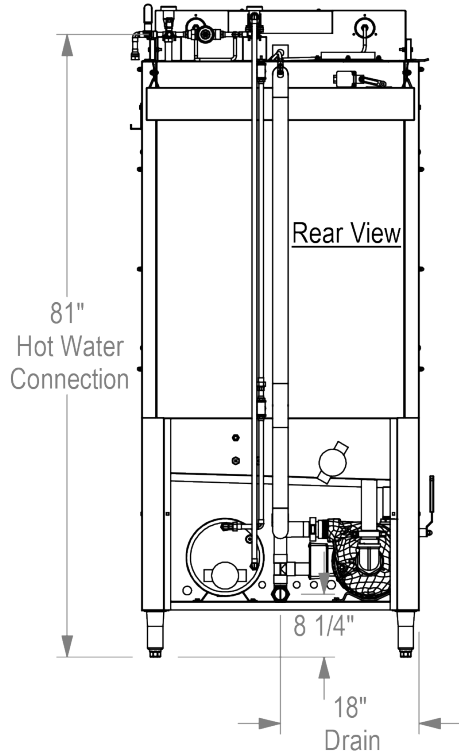

Note: Height with door open - 106"
Door opening width - 32"
Door opening height - 30"

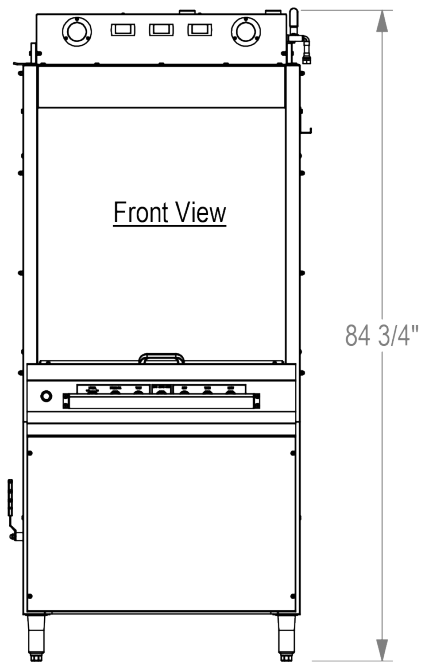
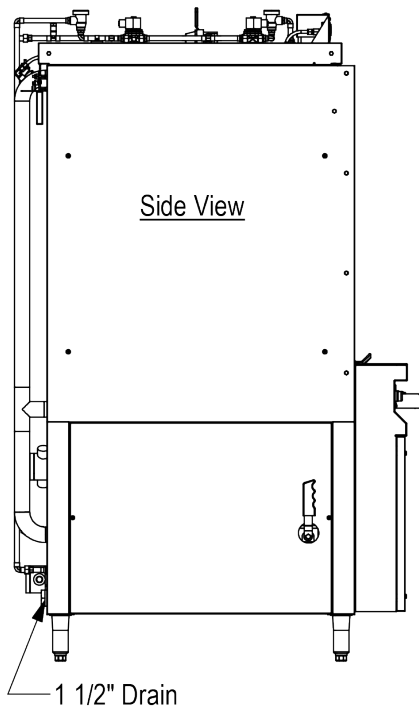

Technical Drawings

Pass Through

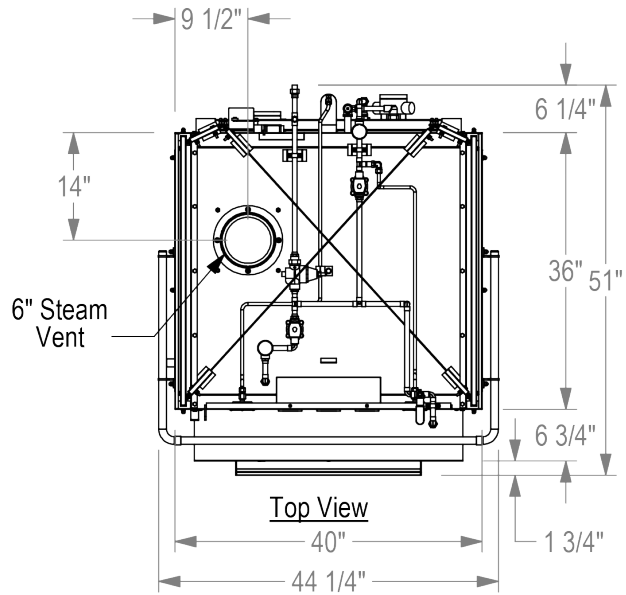
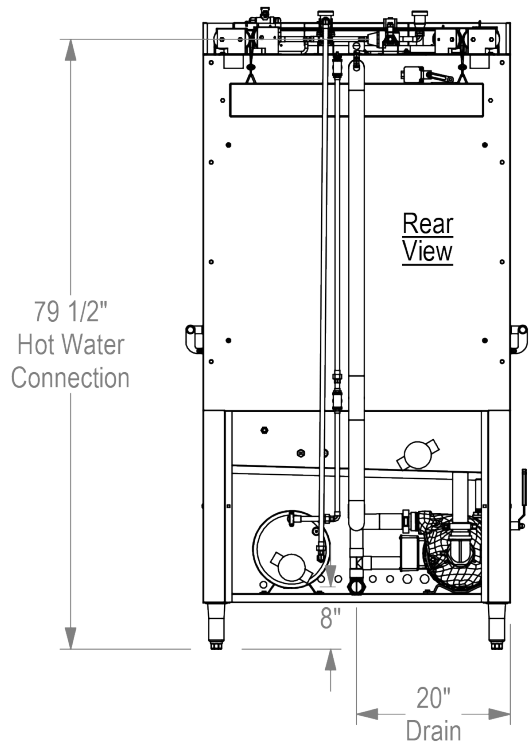

Note: Height with door open - 105 1/4"
Door opening width - 32 1/4"
Door opening height - 29 3/4"

