



# KITCHEN-IN-A-BOX

## OCTOPUS

### INDUCTION COOKERS FOR PROFESSIONALS

High energy efficiency (90%+)

- Stainless steel casing
- Countertop installation
- Easy-to-clean capacitive touch controls
- Superior air flow and cooling for all day use
- Two (2) zones with precision controls
- Automatic pan detection/power supply monitor
- Empty pan security/automatic overheating protection
- Removable washable grease filter cleans air intake
- Accessory storage compartment
- Cooking Modes: Power level, Temperature (Celsius), Plancha or Grooved Grill



Maximum Power Setting Examples	
Zone 1	Zone 2
30 (3000W)	OFF
15 (1500W)	15 (1500W)
20 (2000W)	10 (1000W)
5 (500W)	25 (2500W)
W = power output in WATTS	

- Maximum power both sides = 3000
- Maximum power one side = 3000

**INCLUDED:**

- Two zone induction cooker with (2) retractable arms each side
- Removable cast iron flat and ribbed grill plates
- Removable wood cutting board (13"W x 9 5/8"D)
- Removable splash shields (2) and covers (2)
- Stainless steel spatula and cooking tongs
- Stainless steel removable side shelves (2)
- Accessory storage compartment

**OPTIONAL:**

- (1) set of three 1/9 GN size polycarbonate pans (2.5"D) with covers and stainless-steel frame

**OCTOPUS 3000**

208/240 V

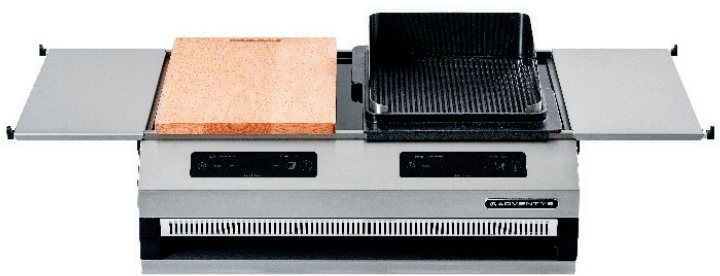

Removable Air Filter



Precision Capacitive Touch Controls  
Accessory Storage Compartment Below



100 NIAN TIC AVENUE; SUITE 104 PROVIDENCE, RI 02907  
 TEL: (401)273-3300 FAX: (401) 273-3328 E-mail: sales@equipex.com  
 www.equipex.com

# ADVENTYS

## OCTOPUS 3000

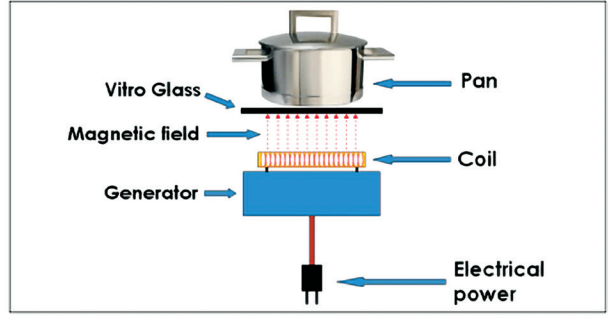
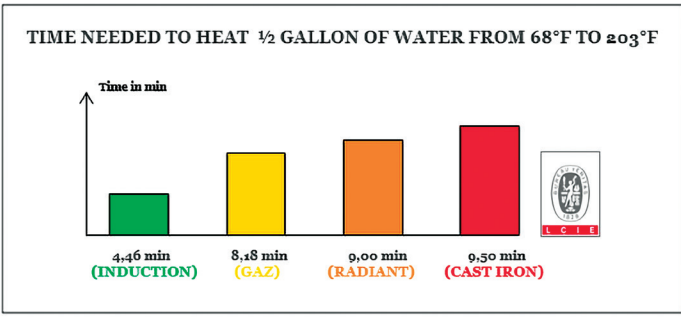
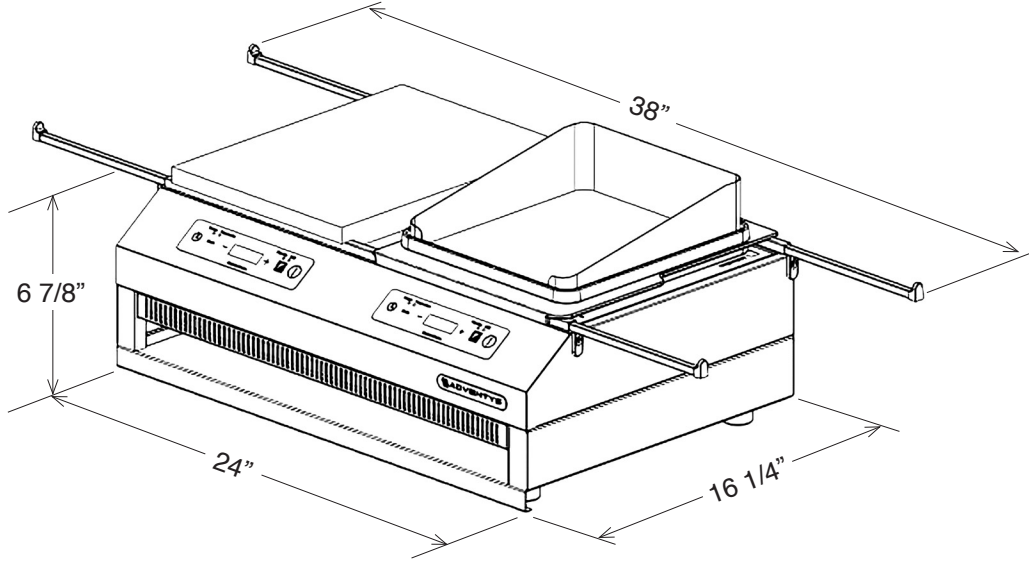

**INDUCTION TECHNOLOGY**

**How does it work?** Induction is a basic principal of physics. When the electric current goes through a copper coil it creates a magnetic field. The pan attracts the magnetic field and creates heat. Induction technology is over **90% efficient**, therefore there is no waste of power of heat. As soon as the pan is removed, the induction unit turns off and **saves you energy**.

## SPECIFICATIONS

CLEARANCE: 4" EACH SIDE AND REAR MAXIMUM AMBIENT TEMPERATURE: 130F  
 NOTE: REQUIRES THE USE OF INDUCTION READY COOKWARE

MODEL	ELECTRICAL	EXTERIOR DIMENSIONS	WORK SURFACE DIMENSIONS	SHIPPING WEIGHT	NEMA PLUG
OCTOPUS 3000	208/240V, 1PH 3.0KW, 13/15 Amps	24"W x 16 1/4"D x 6 7/8"H ----- ADD 7" EACH SIDE FOR SIDE SHELVES	Induction Cooker: 23 1/4"W x 14 3/4"D ----- Grill/Plancha Plate ea. 9 3/8"W x 10 3/8"D	105 lbs	6-20P

\*All equipment must be plugged into a dedicated circuit of the proper ratings.

**WARRANTY: Limited two-year parts and labor**



100 NIANTIC AVENUE; SUITE 104 PROVIDENCE, RI 02907  
 TEL: (401)273-3300 FAX: (401) 273-3328 E-mail: sales@equipex.com  
 www.equipex.com