



Project \_\_\_\_\_  
 AIA # \_\_\_\_\_ SIS # \_\_\_\_\_  
 Item # \_\_\_\_\_ Quantity \_\_\_\_\_ C.S.I. Section 114000



## PS40 Scale



### MODEL

**PS40-3** Includes Security Seal

### STANDARD FEATURES

- + Simple touch key operation with audible “beep” response
- + Bright backlit displays
- + Up to 50 programmable keys; 12 direct, 38 indirect
- + Wipe clean keypad
- + Stainless steel platter
- + NSF approved
- + Legal for trade
- + Rechargeable battery with power cord (up to 80 hour battery life)
- + Ships pre-calibrated to end user

**PS40 SCALE**

### SPECIFIER STATEMENT

The PS40 scale is a portioning and price computing scale with up to 50 programmable keys and a bright backlight display. The PS40 is NSF certified and features a stainless steel platter, wipe clean keypad and a rechargeable battery with a power cord to offer up to 80 hours of battery life.

Approved by \_\_\_\_\_ Date \_\_\_\_\_ Approved by \_\_\_\_\_ Date \_\_\_\_\_



## SPECIFICATIONS

**Capacity:** 30 lbs. x 0.01 lbs.

**Scale Housing:** 13.9"W x 13"D x 4.9"H.

**Platter:** Stainless Steel, 12.8"L x 9.6"W.

**Display:** Backlit LCD displays, front and back; .75" high digits (20 mm); displays unit weight, unit price, and total price in 6 digit increments.

**Keyboard:** Membrane wipe down keyboard with audio feedback.

**Electrical:** AC plug in adaptor: Input 100-240V; Battery operation via 6V 4amp sealed rechargeable battery.

**Operating Range:** 14°F to 104°F; -10°C to +40°C.

**Weight:** Net: 9.3 lbs., Shipping: 15 lbs.

## DETAILS AND DIMENSIONS

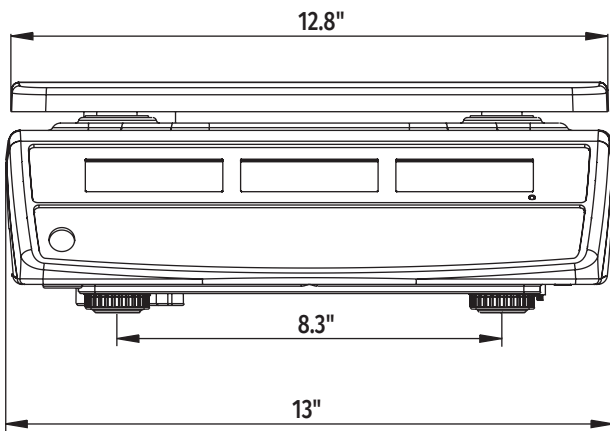

Front View

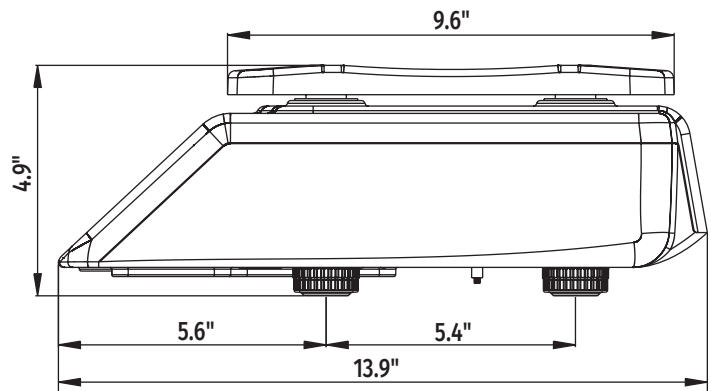

Side View

As continued product improvement is a policy of Hobart, specifications are subject to change without notice.