



Spray Valves

5SV-WH

TAG:

Spray Valve with Handle

Architect/Engineering Specifications:

High flow spray valve, polished chrome plated brass body with rubber bumper, heat resistant handle and 1/2" NPT female inlet. Certified to ASME A112.18.1/CSA B125.1, NSF 61-Section 9 and NSF 372.

| | |
|----------------------|----------------------|
| Job Name | _____ |
| Model Specified | _____ Quantity _____ |
| Variations Specified | _____ |
| Date | _____ |

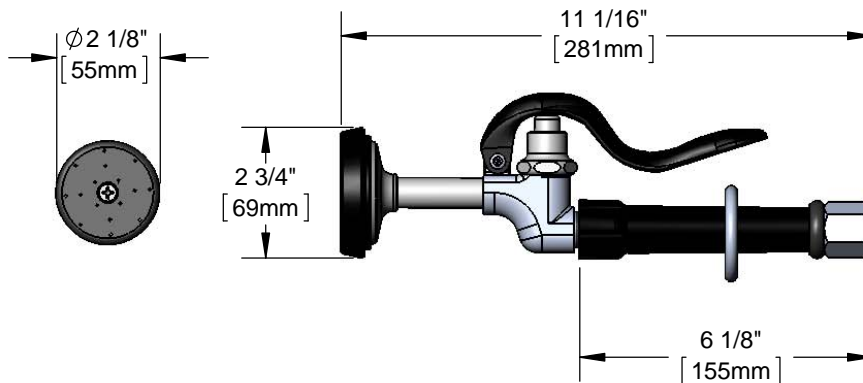
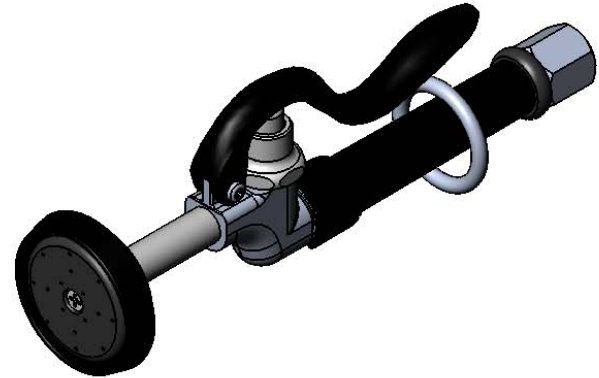

Features & Benefits:

- Designed for heavy-duty use in industrial kitchens
- High flow spray valve w/ heat resistant black handle and hold down ring
- Shuts off when handle is released
- 1/2" NPT female inlet
- Material: Polished chrome plated brass body, rubber bumper and plastic handle

Product Compliance:

- ASME A112.18.1 / CSA B125.1
- NSF 61 - Section 9
- NSF 372 (Low Lead Content)
- EPA 2005 Non-Compliant (PRSV)
- Product Not Designed/Intended For Commercial Warewashing in North America



Warranty: One Year (Limited)

Performance Data:

- Pressure: 20 - 125 psi
- Temperature: 40 °F - 140 °F
- Flow Rate: 4.5 GPM @ 60 psi



equip Foodservice Accessories



• 2 Saddleback Cove • Travelers Rest, SC 29690
Ph 800-891-4808 • Fax 800-868-0084
www.tsbrass.com

Date: 10/20/16