

# SHALLOW DEPTH BASE UNDERCOUNTER REFRIGERATOR

## Model: RA93SN-U-D

Natural Refrigerant R-290 Model

### 93" Shallow Depth Base Undercounter Refrigerator with Drawers



ENERGY STAR® Qualified Commercial Refrigerator

Heavy gauge #300 series stainless steel top, stainless steel front and end panels, galvanized steel rear and grills and aluminum interior.



## Options and Accessories

(upcharge and lead times may apply)

Stainless steel interior	Condensing unit left (standard on right)
Stainless steel back	Door & drawer locks
Drawer in lieu of door section above the condensing unit*	

Consult factory for other model configurations, options and accessories.

\*Drawer section above condensing unit holds (4) 1/6 pans



Project Name:

Model Specified:

Location:

Item No:

Quantity:

AIA #:

SIS #:

## Standard Model Features

### REFRIGERATION SYSTEM

Performance rated refrigeration system

Natural, environmentally safe, high efficiency R-290 refrigerant<sup>1</sup>

Unique forced air design utilizes fans (approx. every 12") across the entire back of unit for even distribution of cold

Automatic, hot gas condensate evaporator

Non-corrosive, plasticized fin evaporator coil

Easily serviceable, slide out condensing unit

Expansion valve system

### CABINET ARCHITECTURE

2" non-CFC polyurethane foam insulation

Smooth, polished chrome door & drawer handles

Spring loaded, self closing door over condensing unit

Magnetic snap in Santoprene™ door gaskets

Stainless steel roll out drawers

Completely enclosed, vented and removable rear and side grills

1 3/8" diameter plate casters on heavy duty support plates (easily field installed)

### MODEL FEATURES

Refrigerated section with door above the condensing unit

Front breather air divider (field installed)

Electronic control, off-cycle defrost

Field rehingeable door over condensing unit

<sup>1</sup> R-290 refrigerant meets all federal and state regulatory requirements.

**NOTE:** Models come standard with a door above the condensing unit. A drawer above the condensing unit is an option.

APPROVAL:

# Model Specifications

## DIMENSIONAL DATA

Net Capacity (cubic feet)	25.6 (725 cu l)
Width, Overall (inches)	93 (2367 mm)
Depth, Overall (inches) (including handles & bumpers)	31 (770 mm)
Height, Overall (inches) (including 1 3/8" casters)	32 (806 mm)
Number of Drawers	6
Number of Half Doors	1
Interior Depth (inches)	24 (610 mm)
Interior Height (inches) (above condenser)	12 1/2 (318 mm)

## REFRIGERANT DATA

Condensing Unit Size (H.P.)	1/4+
Capacity (BTU per hour)*	5260

## ELECTRICAL DATA

Voltage (International)	115/60/1 (220/50/1)
Total Amps (International)	5.06 (3.4)
10 ft. Cord/Plug [attached] (International)	Yes (No)

## SHIPPING DATA

Weight (pounds)	460 (209 kg)
Height - Crated (inches)	43 3/4 (1111 mm)
Width - Crated (inches)	95 (2413 mm)
Depth - Crated (inches)	47 (1194 mm)

## DRAWER PAN CONFIGURATIONS

**Two Tier:** (1) 12 x 20 x 6 pan per drawer (supplied by others)

\* Rating @ +25°F evaporator, 90°F ambient  
Figures in parentheses reflect metric equivalents rounded to the nearest whole unit



Equipped with one NEMA-5-15P Plug  
(varies by country)

# Model Plan Views

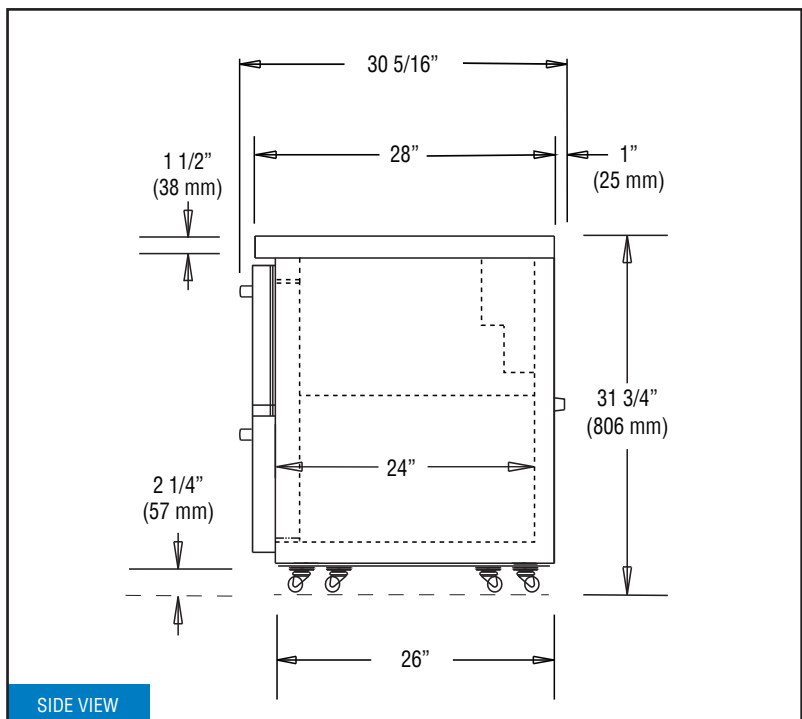
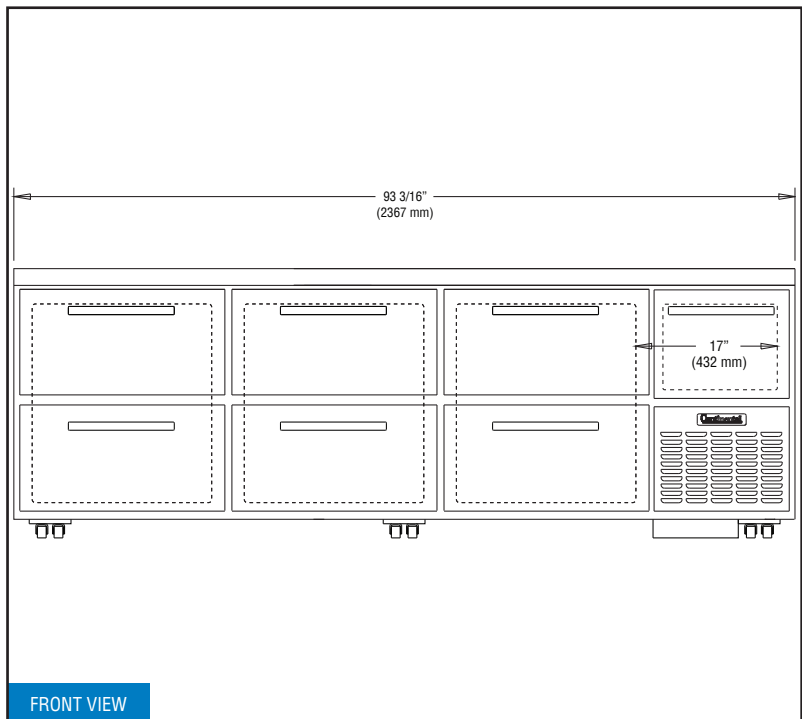

**Continental**  
Refrigerator

Toll-Free: 800-523-7138  
Phone: 215-244-1400  
Fax: 215-244-9579

539 Dunksferry Road  
Bensalem, PA 19020  
[www.continentalrefrigerator.com](http://www.continentalrefrigerator.com)

Due to our continued efforts in developing innovative products, specifications subject to change without notice.



PROUDLY  
DESIGNED & ASSEMBLED  
IN THE U.S.A.

**Intertek**

© Copyright 2021. Continental Refrigerator.  
A Division of National Refrigeration & Air Conditioning Products, Inc.

REVISED: 1/22/24