

DINEXPRESS SOLID TOP COUNTER

Compliant with
NSF/ANSI Standard 2



DXP3ST
(shown with optional elementary height
solid tray slide and formica finish)

Item Numbers

DXP2ST
DXP3ST
DXP4ST
DXP5ST
DXP6ST

DineXpress Solid Top units are ideal for use as worktops for plating and for sandwich and salad preparation. They can also be used as a counter for other serving and merchandising needs. These units are in stainless steel and available in different lengths and many options/accessories can be added to fit your needs.

Standard Features

- 14-gauge stainless steel top with 1-1/2" turn down on all sides
- Top secured by four recessed bolts
- 14-gauge stainless steel legs fastened to 18-gauge stainless steel bottom shelf
- 20-gauge stainless steel end and front panels are attached to legs
- Open control side for additional storage capacity
- 5" diameter swivel plate casters, 2 with brakes

Dimensions

DXP2ST – 36"H x 28"D x 32"L

DXP3ST – 36"H x 28"D x 46"L

DXP4ST – 36"H x 28"D x 60"L

DXP5ST – 36"H x 28"D x 74"L

DXP6ST – 36"H x 28"D x 88"L

36" height on all standard units

30" height is available on Petite Elite units

28" width

32" to 88" length in 14" increments

Common Options

- Pizzazz powder coating in lieu of stainless steel
- Tray slides
- Protector guards
- Hinged or sliding doors
- See reverse side for additional options.

Warranty

One year parts and labor.

DINEXPRESS SOLID TOP COUNTER

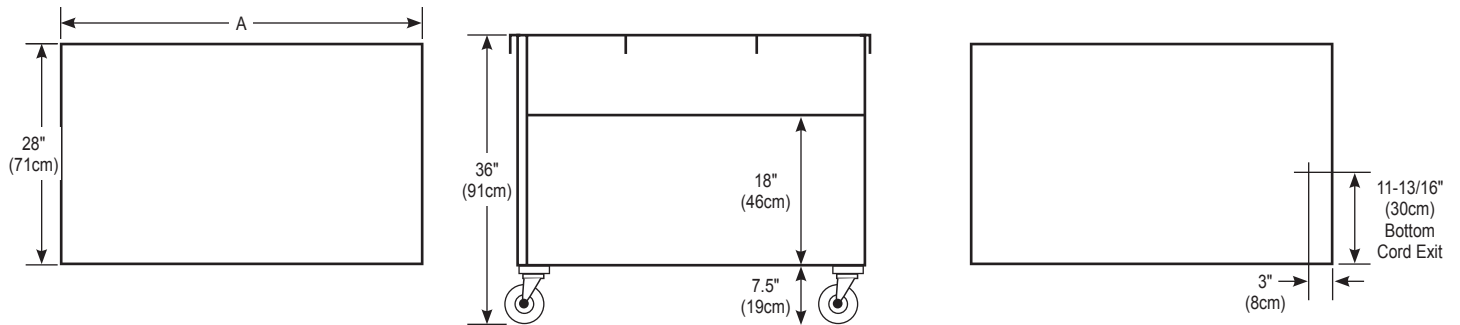

Items and Dimensions

| ITEM NUMBER | LENGTH (A) | WIDTH | HEIGHT | SHIP WEIGHT (LBS) |
|-------------|----------------|---------------|---------------|-------------------|
| DXP2ST | 46" (117cm) | 28" (71cm) | 36" (91cm) | 225 |
| DXP3ST | 46" (117cm) | 28" (71cm) | 36" (91cm) | 265 |
| DXP4ST | 60" (152cm) | 28" (71cm) | 36" (91cm) | 302 |
| DXP5ST | 74" (188cm) | 28" (71cm) | 36" (91cm) | 345 |
| DXP6ST | 88" (224cm) | 28" (71cm) | 36" (91cm) | 500 |

Dimension Additions For Options

- Add 23-3/4" to height for buffet protector guard
- Add 14" to height for cafeteria protector guard
- Add 22-3/4" to height for double display shelf
- Add 8" to width for cutting board
- Add 12-3/4" to width for solid ribbed tray slide
- Add 12-1/2" to width for 3-bar tray slide

Note: Line-up drawing required when ordering false front, cashier stand or interconnected units.

| ITEM NO | DESCRIPTION |
|----------|---|
| DXPPPC | Pizzazz Powder Coating |
| DXPSCB | 8" stainless steel cutting board, flush with top |
| DXPMCB | 8" maple cutting board, flush with top |
| DXPSRTS | Solid 3-ribbed tray slide, 16-gauge stainless steel |
| DXP3BTS | 3-bar tray slide |
| DXPMBS | 18" maple end bread shelf; left, right - flush with top |
| DXPSBS | 18" stainless steel end bread shelf; left, right - flush with top |
| DXPCPG | Cafeteria protector guard (no heat or lights) |
| DXPCPGL | Cafeteria protector guard with incandescent lights |
| DXPCPGFL | Cafeteria protector guard with fluorescent lights |
| DXPCPGHL | Cafeteria protector guard with heat and lights |
| DXPCDD | Cafeteria double display (no heat or lights) |
| DXPCDDL | Cafeteria double display with fluorescent lights |
| DXPBG1 | Buffet single side protector guard (no heat or lights) |
| DXPBG1IL | Buffet single side protector guard with incandescent lights |
| DXPBG1FL | Buffet single side protector guard with fluorescent lights |
| DXPBG | Buffet double side protector guard (no heat or lights) |
| DXPBGIL | Buffet double side protector guard with incandescent lights |

| ITEM NO | DESCRIPTION |
|----------|---|
| DXPBGFL | Buffet double side protector guard with fluorescent lights |
| DXPBGH | Buffet double side protector guard with heat strip |
| DXPBDD | Buffet double display two-sided protector guard |
| DXPBPGC | Buffet classic two-sided protector guards |
| DXPCPGC | Cafeteria Style Classic (1-5/8) protector guards |
| DXPCDDC | Cafeteria Style Classic Double Display protector guards |
| DXPBG1C | Buffet Style Classic Single Sided protector guards |
| DXPSCPGC | Cafeteria Style Classic Single protector guards |
| DXPSSL | Legs in lieu of casters |
| DXPDOUT | Duplex outlet (120V, 15 AMP) |
| DXPFRMA | Formica laminate finish without doors |
| DXPCUT | Cut out for drop in dispensers. |
| DXPUCR-1 | Refrigerated storage base with doors and pan slides 60" or larger |
| DXPUCR-2 | Refrigerated storage base 74" or larger |
| DXPINT | Intermediate shelf |
| DXPSKR | Skirting |

Please confirm that you have the most current specification sheet by visiting www.dinex.com.

It is Dinex's policy to offer equipment which is design certified by companies that have been accredited at the federal level by the Occupational Safety and Health Agency (OSHA) and ANSI as a national recognized testing laboratory. These companies include CSA International, Underwriters Laboratories, Edison Testing Laboratories and National Sanitation Foundation. However, a continuing program of product improvement makes it necessary to submit new models to the agencies as they are developed. Consequently, all models may not bear the appropriate labels at all times.

Dinex reserves the right to change specifications and product design without notice. Such revisions do not entitle the buyer to corresponding changes, improvements, additions or replacements for previously purchased equipment.



DINEX®

4711 E. Hefner Road
Oklahoma City, OK 73131
800.654.8210 | 405.475.5600
www.dinex.com