

Champion®

The Dishwashing Machine Specialists

Project _____

Item No. _____

Quantity _____

PRO SERIES RACK CONVEYOR

STANDARD FEATURES

- Perpetual rack advance system, with intuitive jam alert, and drive protection
- Proportional rinse, delivering unmatched total ware coverage, utilizing digital pattern cloning stainless steel nozzles
- Programmable de-lime notifications and de-lime automated cycles
- 255 Racks per hour
- 100 GPH with energy sentinel (idle pump shut-off)
- Prodigy series HMI display, intuitive condition alerts, with user friendly cleaning and operation visual guidance, multi-lingual, touch control
- Proactive maintenance interface, self-diagnostics, problem recognition, with repair recommendation, from HMI touch screen
- Automatic tank fill
- Programmable machine dwell with automatic rack alignment into the optimal wash zone
- Automatic drain valve
- Single-piece hood design
- Single-piece stainless steel upper and lower wash arm manifolds
- Single-point electrical connection
- 20" Standard vertical clearance which accommodates 18" x 26" sheet pans
- Full 180° opening leak proof insulated hinged access doors
- Stainless steel heavy gauge construction including base, legs and feet
- Enclosure panels (front and sides)
- 2 HP pump motor, with stainless steel impeller
- Factory authorized start-up
- Vent fan control
- **ENERGY STAR® Certified**
- **Made in America**

54 PRO ELECTRIC

High Temperature Electric Rack Conveyor
Dishwashing Machine



Photo is for general visual representation only. Please refer to specifications for the latest detailed product information.

SPECIFIER STATEMENT

Specified unit will be Champion model 54 PRO Series high temperature rack conveyor dishwashing machine. Features top mounted prodigy HMI user interface controls with proactive maintenance software, proportional rinse, using only 100 GPH, optional built-in 21kW booster, progressive anti-jam drive system, energy sentinel (idle pump shut-off), 255 racks per hour, single-piece hood design, single-piece stainless steel upper & lower wash arms manifolds, full 180° opening leak proof insulated hinged access doors.

1 Year parts and labor warranty.



Champion Industries, Inc.
3765 Champion Blvd., Winston-Salem, NC 27105
Tel: 336-661-1556 Fax: 336-661-1979
championindustries.com

Champion Industries, Inc.
2764 North Service Rd., Jordan Station, Ontario Canada L0R 1S0
Tel: 905-562-4195 Fax: 905-562-4618
championindustries.com/1canada

CH070

54 PRO ELECTRIC

High Temperature Electric Rack Conveyor
Dishwashing Machine

Champion[®]
The Dishwashing Machine Specialists

OPTIONS

- Two-point electrical connection, separate for machine and booster (field convertible)
- 33" Blower dryer – electric
- Booster heaters (completely interplumbed, controls are interwired)
 - 40°F Rise (built-in) (field converted)
 - 70°F Rise (built-in)
- Direct link connectivity solution
- Direct link plus+ connectivity solution

ACCESSORIES

- Drain water tempering kit (unmounted)
- Table limit switch, unmounted (recommended on all rack conveyor installations)
 - Whisker style
 - Button style
- Vent cowl, stainless steel with 7" stacks & locking dampers
- Extended vent cowl, with 7" stacks, locking dampers & external curtain
- Flanged feet (unmounted)
- Water hammer kit (unmounted)
- Chemical pump kit (detergent and rinse aid, mounted and interwired)
- Water pressure regulating valve (unmounted) (standard with booster)
- ION scale prevention device (unmounted)
- Water softening system (manufactured, warranted and serviced by Kinetico)
- Dish racks:
 - Peg rack
 - Flat rack
 - Sheet pan rack
- Splash shields
- Cantilever sideloader (without hood) for 90° load operation
 - 24" Sideload
 - 30" Sideload (accepts sheet pans)
- Model PRO-90B loader or unloader (90° corner conveyor table)
- Model RCT 64 or RCT 84 roller conveyor table (see factory for custom length)
- Stainless steel rear enclosure panels
- Correctional package (contact factory)



NEW PRO-90B
90° Corner Conveyor
table (shown)
Loader or Unloader



Cantilever Sideloader
(no hood)



**Model RCT 64 or
RCT 84**

Roller conveyor
table

54 PRO ELECTRIC

High Temperature Electric Rack Conveyor
Dishwashing Machine



Utilities	
1	Electrical Connection Machine electrical connection and booster electrical connection
2	Hot Water Machine with built-in booster Main connection 1/2" NPT
4	Hot Water Machine with no booster Main water connection 1/2" NPT
5A	Drain Connection 1-1/4" NPT Drain Max Flow Rate (g/min) 15
8	Vents A Stack connection - load end 200 CFM @ 1/4" static pressure B Stack connection - unload end 400 CFM @ 1/4" static pressure

Warning: Plumbing and electrical connections should be made by qualified personnel who will observe all the applicable plumbing, sanitary, safety codes and the National Electrical Code.

Note: Water Hammer Arrestor (meeting ASSE-1010 standard or equivalent) to be supplied (by others) in common water supply line at service connection.

Plumbing Notes: Because of the variation in house-supplied steam and water pressures, steam and water pressure regulating valves (PRVs) may be needed. (Water PRV is standard on machines with booster.) The PRVs can either be purchased from Champion or obtained locally.

Recommended water hardness of 3 grains/US Gal (0.83 Imp Gal) - 5.3 Mg/L or less

Venting Notes: Fabricated duct size: 3-7/8" x 15-7/8" (outside dimensions)

Optional Drain Tempering: 1/2" NPT cold water connection required. 1/2" NPT drain connection from back flow preventer to house drain. (FIELD INSTALLED and PLUMBED).

Single Tank PRO Rack Machine and Booster Ratings

The tables below give the ratings for each model. The ratings include the requirements of the 12 and 21 kW booster heaters when they are use.

Machines with a single point electrical connection:

54 PRO Electric Tank Heat, 21 kW 70° Booster			
Electrical Specifications	Rated Amps	Minimum Supply Circuit Ampacity	Maximum Overcurrent Protective Device
208/60/3	111	150	150
240/60/3	96	125	125
480/60/3	47	60	60
575/60/3	40	50	50

54 PRO Electric Tank Heat, 12 kW 40° Booster			
Electrical Specifications	Rated Amps	Minimum Supply Circuit Ampacity	Maximum Overcurrent Protective Device
208/60/3	85	110	110
240/60/3	74	100	100
480/60/3	36	50	50
575/60/3	31	40	40

54 PRO Electric Tank Heat, No Booster			
Electrical Specifications	Rated Amps	Minimum Supply Circuit Ampacity	Maximum Overcurrent Protective Device
208/60/3	52	70	70
240/60/3	45	60	60
480/60/3	22	30	30
575/60/3	19	25	25

SPECIFICATIONS

Capacity

Racks per hr. (NSF rated).....	255
Wash tank (US gal.).....	17
Conveyor speed (ft./min.).....	7.1
Conveyor speed Pot/Pan Mode (ft./min.).....	5.4
(only one rack at a time in pot/pan)	

Motor Horsepower

Drive.....	1/6
Wash.....	2

Water Consumption

US Gal. per hr. (max use).....	100
US Gal. per rack.....	.39

Heating

Tank Heat, electric (kW).....	15
Electric booster (built-in) (kW supplied for 40°F rise).....	12
Electric booster (built-in) (kW supplied for 70°F rise).....	21

Booster heaters completely inter plumbed, controls are interwired.

Venting

Load end (minimum CFM).....	200
Unload end (minimum CFM).....	400

Standard 20" X 20" rack complement

Peg.....	1
Flat.....	1

Machines with a dual point electrical connection:

54 PRO Electric, 21 kW Booster Only			
Electrical Specifications	Rated Amps	Minimum Supply Circuit Ampacity	Maximum Overcurrent Protective Device
208/60/3	59	80	80
240/60/3	51	70	70
480/60/3	26	35	35
575/60/3	22	30	30

54 PRO Electric, 12 kW Booster Only			
Electrical Specifications	Rated Amps	Minimum Supply Circuit Ampacity	Maximum Overcurrent Protective Device
208/60/3	34	45	45
240/60/3	29	40	40
480/60/3	15	20	20
575/60/3	12	15	15

Note: Machine ships as a single point electrical connection standard. Easily converted to a dual point connection by a qualified electrician.

54 PRO ELECTRIC

High Temperature Electric Rack Conveyor
Dishwashing Machine

Champion®

The Dishwashing Machine Specialists

MODEL 54 PRO ELECTRIC

Shipping weight crated: **650 lbs.**

Dimensions shown in inches [mm]

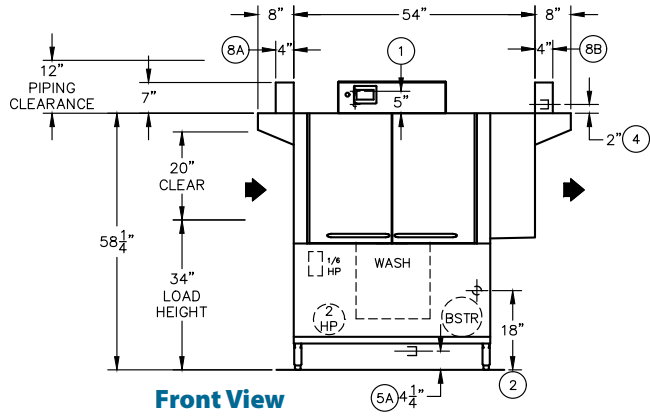

**Front View
Left to Right**

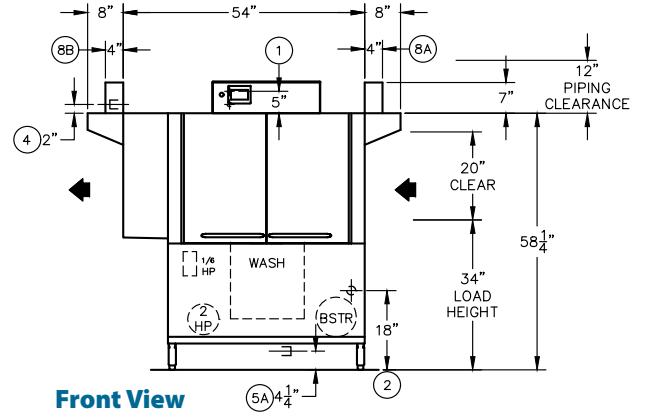

**Front View
Right to Left**

**Plan View
Left to Right**

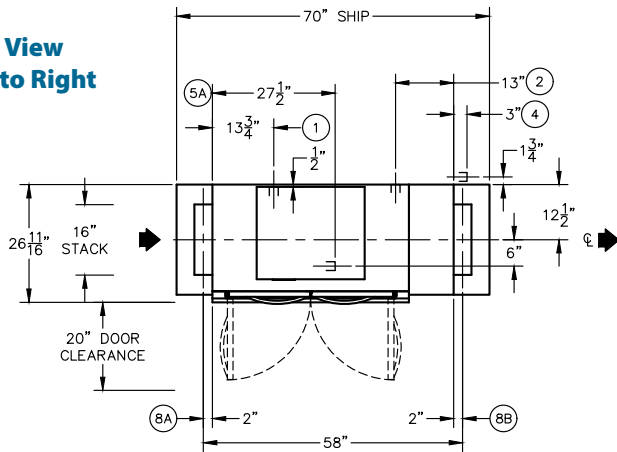

**Plan View
Right to Left**

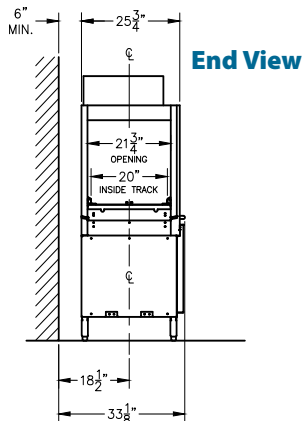
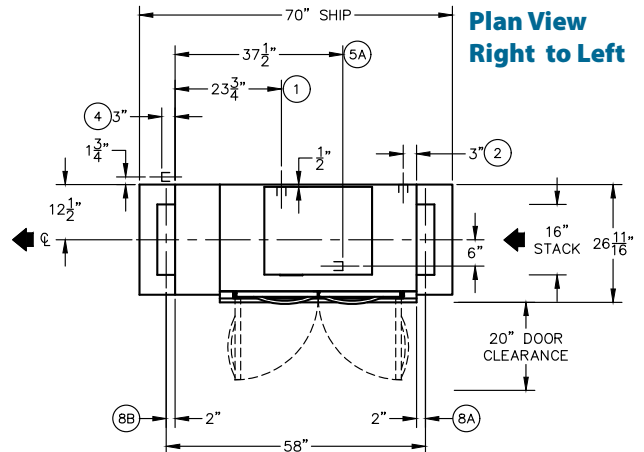

End View

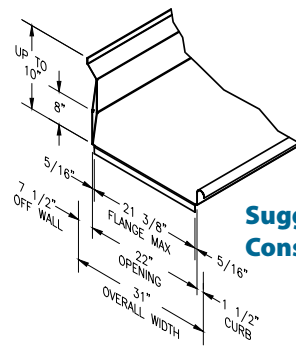

**Suggested Table
Construction**

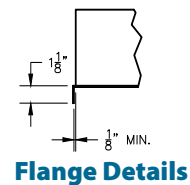

Flange Details