



TÜVRheinland®
Sistema de
Gestión
ISO 9001:2008



JOSPER BASQUE GRILL



TECHNICAL INFORMATION

Braising area	19 3/4 x 20 1/8 in (x2)
Grill stroke	11 1/2 in
Fire up time	20 min average
Charcoal consumption	44 to 48.5 lb average
Broiling temperature	482 °F
Power equivalent	6 hp
Exhaust rate	2060 cfm
Net weight	809.1 lb

INSTALLATION

Clearance with nonflammable equipment	4 in
Clearance with inflammable equipment	12 in

BUNDLES: SIZES AND WEIGHTS

Sizes bundle	59 7/8 x 42 1/2 x 71 5/8
Gross weight bundle	-

PVJ - 050 - 2

High-temperature resistant element which guarantees smooth, continuous movement of the grill. In the manufacturing process of the BASQUE GRILL we use the best high technology steel alloys created by and for JOSPER, as well as the most advanced design in the construction of traditional grills.

The Basque Grill has been designed for optimal thermal insulation: Exclusive ventilation system based on multi-chambers air circuit. Inside protection barrier with mineral insulation. Heat conduction unforced flow, limiting heat transfer to reduce the outside temperature of the JOSPER BASQUE GRILL, and thus be easy to fit.

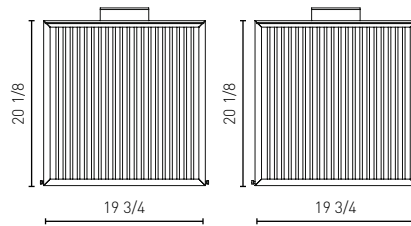

JOSPER BASQUE GRILL

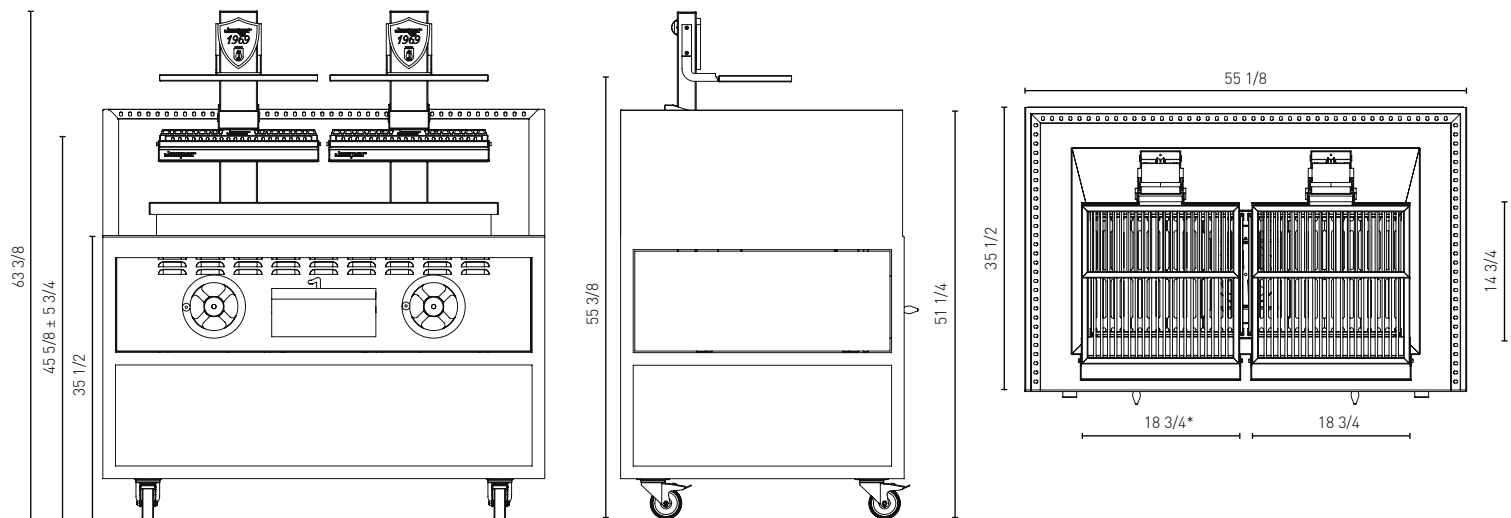
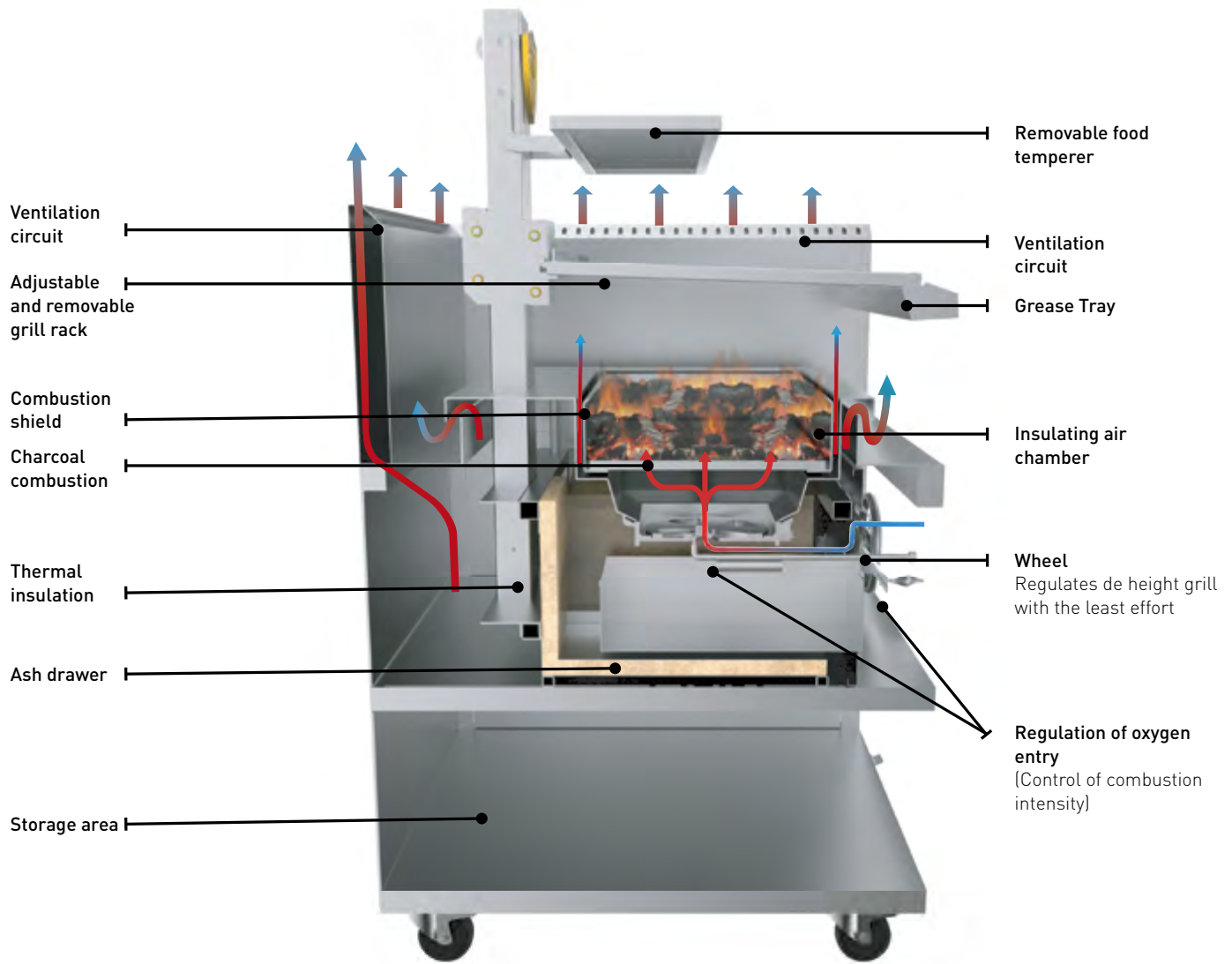

The measures are in inches (in)
* Combustion shield measures

Josper[®]
CHARCOAL EQUIPMENT

JOSPER S.A. Gutenberg, 11
08397 Pineda de Mar - Barcelona - Spain
T +34 93 767 15 16
josper@josper.es
www.josper.es

THE MIDDLEBY CORPORATION

*Passion
for Grilling*[®]
by josper



TÜVRheinland®
Sistema de
Gestión
ISO 9001:2008



BASQUE GRILL

TECHNICAL INFORMATION

Braising area	30 x 20 1/8 in (x2)
Grill stroke	11 1/2 in
Fire up time	20 min average
Charcoal consumption	79.4 to 88.2 lb average
Broiling temperature	482 °F
Power equivalent	8 hp
Exhaust rate	2354 cfm
Net weight	1159.6 lb

INSTALLATION

Clearance with nonflammable equipment	4 in
Clearance with inflammable equipment	12 in

BUNDLES: SIZES AND WEIGHTS

Sizes bundle	86 5/8 x 45 1/4 x 82 3/4 in
Gross weight bundle	1662.3 lb



PVJ - 076 - 2

High-temperature resistant element which guarantees smooth, continuous movement of the grill. In the manufacturing process of the BASQUE GRILL we use the best high technology steel alloys created by and for JOSPER, as well as the most advanced design in the construction of traditional grills.

The Basque Grill has been designed for optimal thermal insulation: Exclusive ventilation system based on multi-chambers air circuit. Inside protection barrier with mineral insulation. Heat conduction unforced flow, limiting heat transfer to reduce the outside temperature of the JOSPER BASQUE GRILL, and thus be easy to fit.

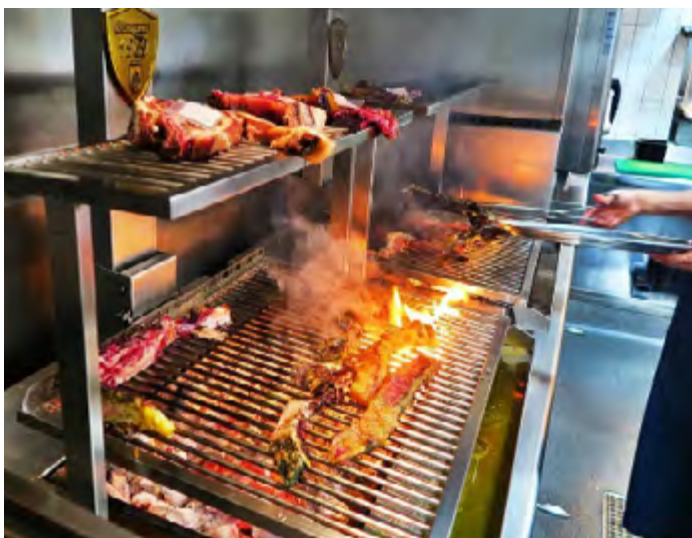
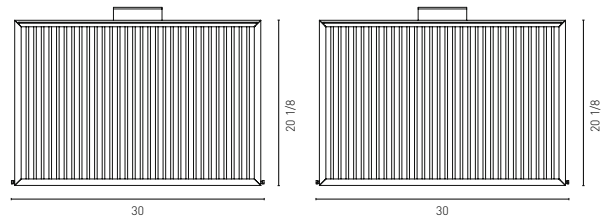

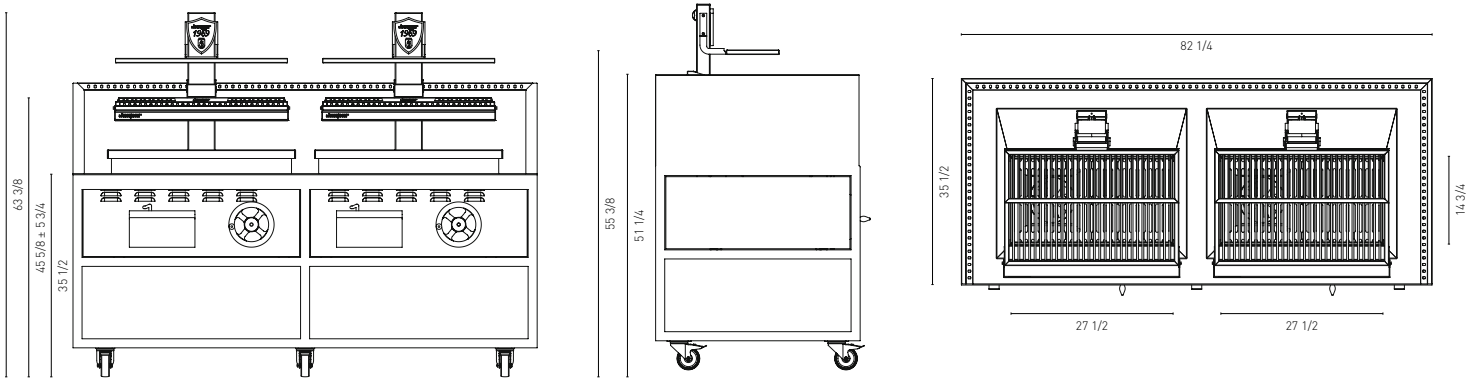
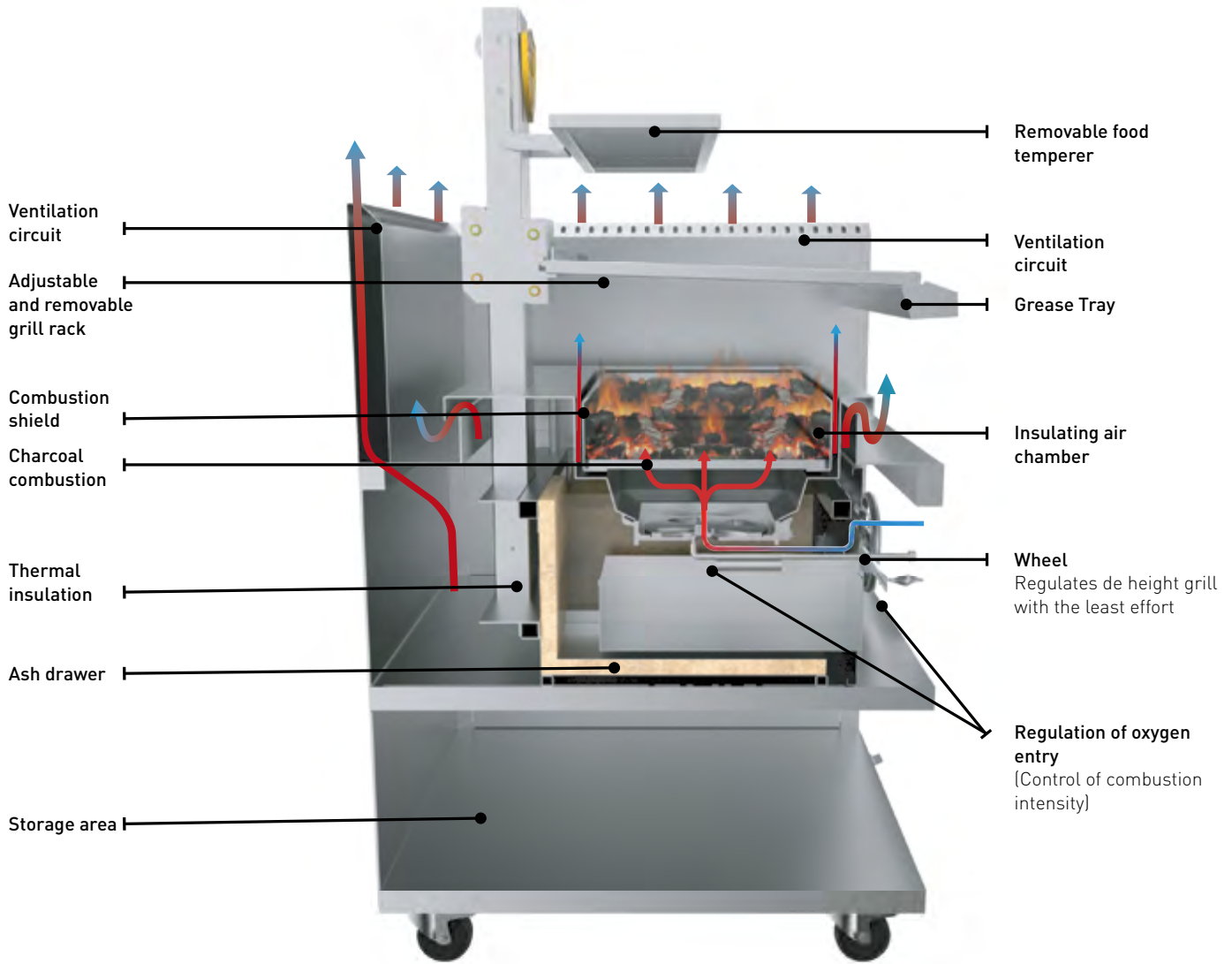

The measures are in inches (in)
* Combustion shield measures



TÜVRheinland®
Sistema de
Gestión
ISO 9001:2008



BASQUE GRILL



TECHNICAL INFORMATION

Braising area	30 x 20 1/8 in
Grill stroke	11 1/2 in
Fire up time	20 min average
Charcoal consumption	39.7 to 44 lb average
Broiling temperature	482 °F
Power equivalent	4.02 hp
Exhaust rate	1471 cfm
Net weight	-

INSTALLATION

Clearance with nonflammable equipment	4 in
Clearance with inflammable equipment	12 in

BUNDLES: SIZES AND WEIGHTS

Sizes bundle	59 7/8 x 42 1/2 x 71 5/8
Gross weight bundle	994.3 lb

PVJ - 076 - 1

High-temperature resistant element which guarantees smooth, continuous movement of the grill. In the manufacturing process of the BASQUE GRILL we use the best high technology steel alloys created by and for JOSPER, as well as the most advanced design in the construction of traditional grills.

The Basque Grill has been designed for optimal thermal insulation: Exclusive ventilation system based on multi-chambers air circuit. Inside protection barrier with mineral insulation. Heat conduction unforced flow, limiting heat transfer to reduce the outside temperature of the JOSPER BASQUE GRILL, and thus be easy to fit.

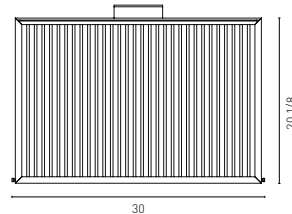

BASQUE GRILL

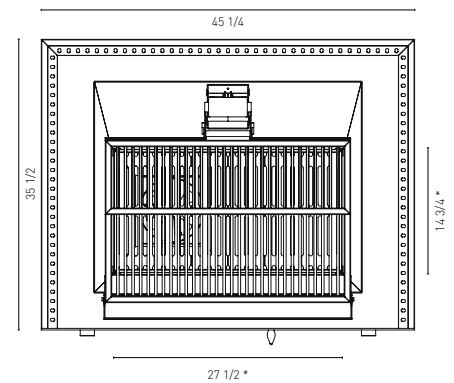
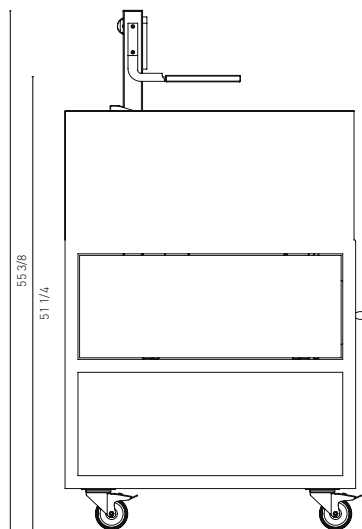
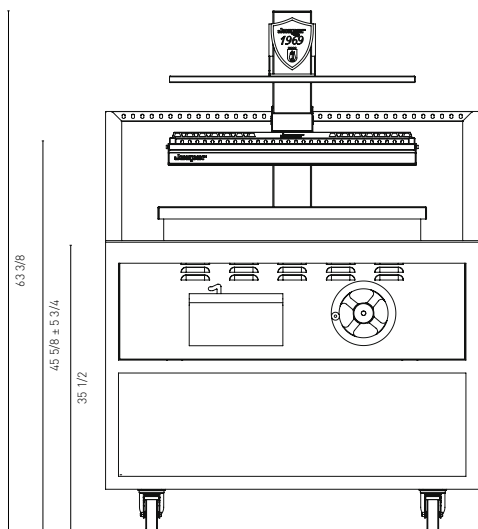
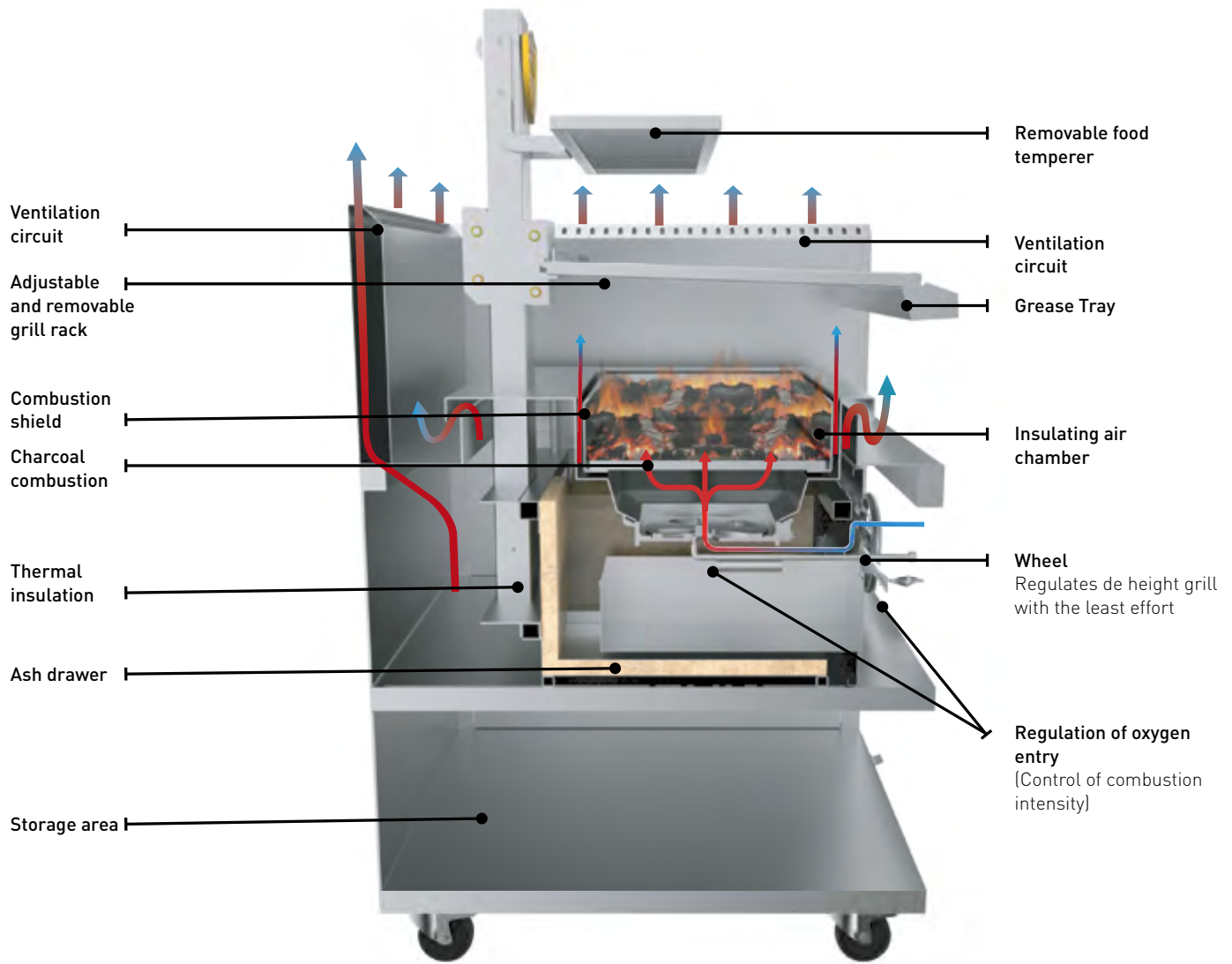

The measures are in inches (in)
* Combustion shield measures