

*Blueair* by  
**BLUENIX**

MODEL BMG480  
**MEAT GRINDER**



## STANDARD FEATURES



- **Gear Powered Screw Motor (1Hp Heavy Duty Motor)**  
This provides you with the essential function to grind meat at a swift pace without crushing or mashing the product.
- **Other Important Benefits**  
Bull Grinder provides superior performance to handle most tough meat and food grinding jobs. This heavy-duty machine grinds 9 to 14 lbs per minute.
- **The Reverse Switch**  
This special feature is intended to maximize productivity by reducing operator fatigue and discomfort.
- **High Quality Stainless Steel Surfaces**  
Meat product will only contact the high quality stainless steel surfaces to ensure cleanliness as well as safety.
- **Easily Removed and Cleaned**  
The bowl assembly and feeding tray can be easily removed and cleaned without the inconvenience of using tools.
- **Safety Opening Function**  
The stainless steel bowl assembly also includes a safety opening function to decrease the possibility of injuries to the user.



[blueairfse.com](http://blueairfse.com)



[orders@blueairfse.com](mailto:orders@blueairfse.com)



1.886.677.8500



223 W. Rosecrans Ave., CA 90248  
T: 310.808.0102

9 W. Shelton Terrace #A, Hillside, NJ 07205  
T: 908-688-0970

# BMG480

Top view

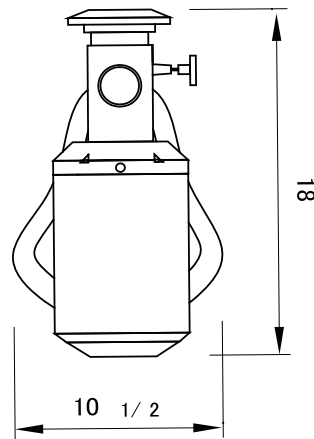

Front view

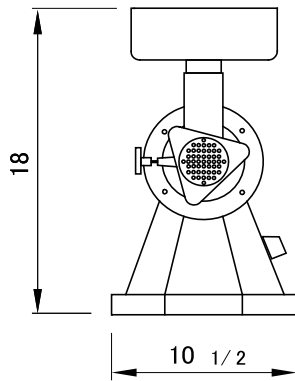

Side view

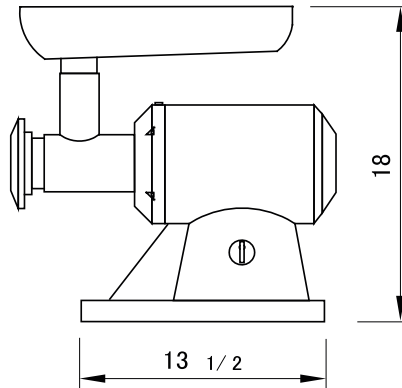

Rear view

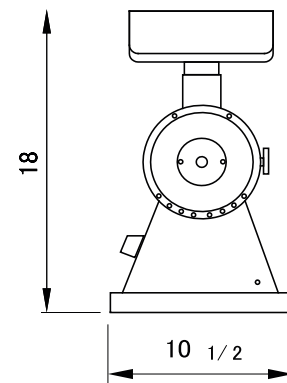

## PRODUCT SPECIFICATION

Model	Cabinet Dimensions (inches/mm)			Max Grinding Capacity (lbs/Min)	Input	Motor Power	Weight (lbs)
	L	D	H				Net Weight
BMG480	10 1/2"	18"	18"	9 to 14	AC110-120V/60Hz	1HP(735W)	51

*Blueair by*  
**BLUENIX**

BLUE AIR has right to change specifications without further notice.



[blueairfse.com](http://blueairfse.com)



[orders@blueairfse.com](mailto:orders@blueairfse.com)



1.886.677.8500



223 W. Rosecrans Ave., CA 90248  
T: 310.808.0102

9 W. Shelton Terrace #A, Hillside, NJ 07205  
T: 908-688-0970