

Aurora Reach-In Beer Bottle Coolers

ITEM:
MODEL:

59039
BB-CN-0014E-HC

59040
BB-CN-0017E-HC



50" wide
59039



65" wide
59040



Stainless steel gliding lid



Lock



Built-in bottle opener



Aluminium coated interior

Built to handle the high demands of your bar, pub, or restaurant

Our Aurora reach-in commercial bottle coolers are durable, efficient, and reliable, these units offer the best value in the industry. Includes auto defrost and a built in bottle opener and catcher.

FEATURES:

- Exterior: heavy-duty, wear-resistant black vinyl finish
- Interior: Aluminum coated
- Stainless steel locking lid for security and longevity
- Epoxy-coated evaporator prevents corrosion
- Removable bottle opener and cap catcher
- Mechanical controller: Temperature range from 7 to 1 (coldest to warmest)

Telephone: 1-800-465-0234

Fax: (905) 607-0234

Email: sales@omcan.com

Website: www.omcan.com



Authorized Dealer



WARRANTY
2 YEARS PARTS AND LABOUR
5 YEARS ON COMPRESSOR

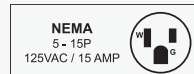

TECHNICAL SPECIFICATION		
Features	50" wide with 13.5 cu.ft. capacity	65" wide with 17.2 cu.ft. capacity
Item	59039	59040
Model	BB-CN-0014E-HC	BB-CN-0017E-HC
Capacity	13.5 cu. ft. (382 L)	17.23 cu. ft. (488 L)
Product Capacity	12 oz. bottles – 16.5 cases 12 oz. cans – 24 cases	12 oz. bottles – 22 cases 12 oz. cans – 32 cases
Number of Lids	2	
Number of Casters	No	
Power	1/6 hp	
Amps	2.3 A	2.6 A
Electrical	115V / 60Hz / 1Ph	
Temperature Controller	Mechanical	
Temperature Range	0.5–3.3°C (33–38°F)	
Refrigerant	R290	
Insulation Material	Cyclopentane	
Cooling System	Ventilated	
Defrosting	Automatic	
Interior Dimensions (WDH)	45" x 23" x 26" (1143 x 584 x 660 mm)	60" x 23" x 26" (1524 x 584 x 600.4 mm)
Net Weight	180.8 lb. (82 kg.)	253.5 lb. (115 kg)
Net Dimensions (WDH)	49.5" x 28" x 34.2" (1257 x 712 x 869 mm)	64.5" x 28" x 34.2" (1638 x 713 x 869 mm)
Gross Weight	247 lb. (112 kg.)	330.7 lb. (150 kg.)
Gross Dimensions (WDH)	56" x 33" x 42" (1422 x 832 x 1061 mm)	70" x 33" x 42" (1778 x 832 x 1061 mm)
Plug Type	NEMA 5-15P	

** This equipment is intended for indoor environment using where ambient temperature do not exceed 24°C(75°F) & 55% relative humidity*

TECHNICAL DRAWING (measurements are in mm)

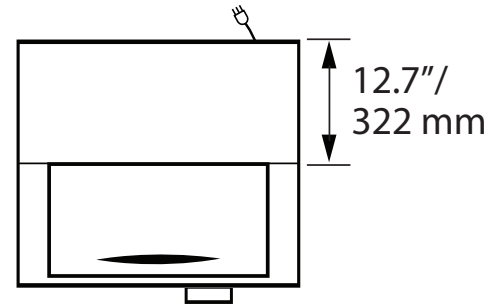
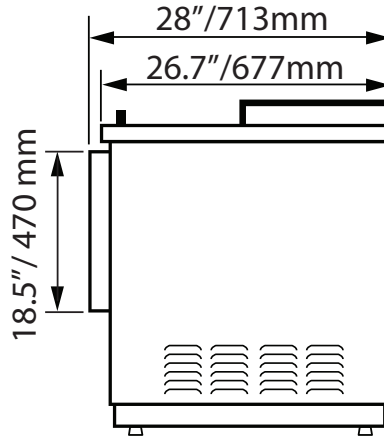
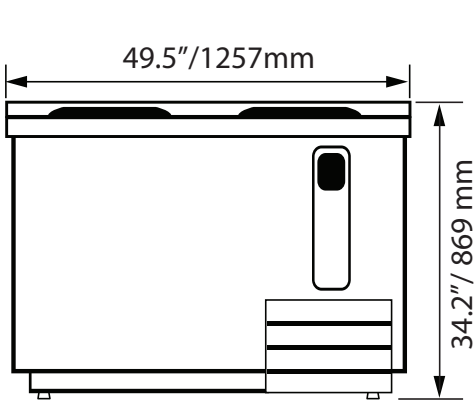

50" wide
59039

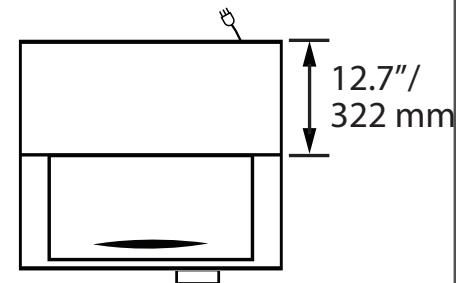
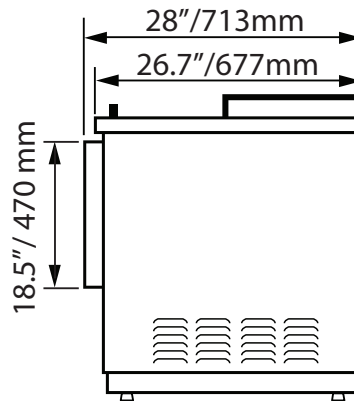
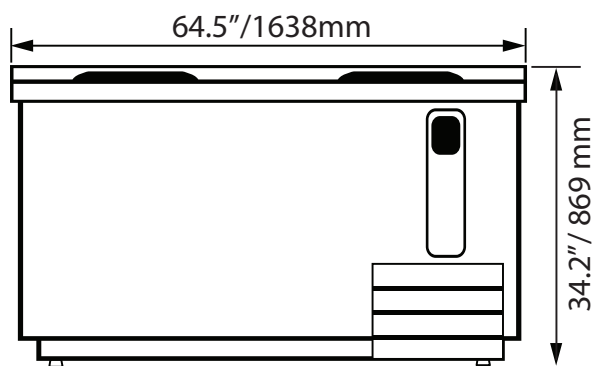

65" wide
59040