



LEGEND™ Heavy-Duty Gas Steakhouse Infrared Broiler With Plancha Plate over Refrigerated Base

Item No. _____

Project _____

Quantity _____

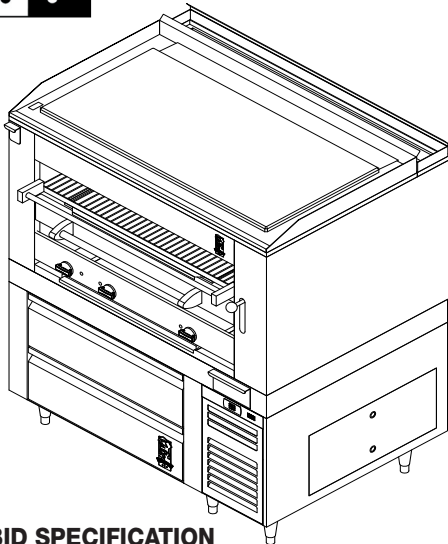

SHORT/BID SPECIFICATION

Broiler shall be a Montague *Legend* Heavy-Duty, *Steakhouse* Broiler with Top Sear Plate over 48" refrigerated base

C45SHPL/RB48-SC 36" (914mm) Wide

...a gas-fired, infrared heated unit with 42,000 BTU/hr cast iron burners with individual controls, heating ceramic radiants mounted below a Spanish-style plancha with raised 1/2" (13mm) thick precision-ground cook surface, 3-sided perimeter grease trough with drop to grease receptacle, a 1/2" (13mm) polished steel searing plate with 4" (102mm) rear and side splash and above; a counter-balanced, height-adjustable, chrome-plated steel cooking grid that is drawer-mounted for easy pull-out access, with a full width grease deflector and large capacity front-mounted grease container; enclosed in an insulated cabinet with stainless steel front and mounted on heavy-duty low ergonomic-height low profile refrigerator designed to support heavy countertop cooking equipment with integrated transition base, 304 Stainless steel front, sides, top, bottom and back, Digital Thermometer, Turbo Coil powered evaporator coil, Heavy-duty, full extension ventilated drawer system, with 2" (51mm) thick foamed in place, environmentally friendly, Non GWP, Non ODP, Kyoto Protocol compliant, polyurethane foam and 6" (152mm) high stainless steel height-adjustable legs standard; plus all the features listed and options/accessories checked:

PLANCHA TOP FEATURES:

- 1/2" (13mm) thick raised polished steel plate
- Interior grease container
- 3-sided grease trough

BURNER/RADIANT SYSTEM FEATURES:

- Three 42,000 BTU/hr cast iron burners
- Ceramic radiants for uniform infrared heating
- Individual burner controls
- Standing pilot for automatic ignition

ROLL-OUT GRID FEATURES:

- Three chrome plated steel grid sections
- Counter-balanced grid assembly for easy height adjustment
- Infinite grid height adjustment from 2" to 5" (51 to 127mm)
- Positive locking lift handle with cool ball-style grip
- Quiet, ball bearing mounted roll-out grid assembly
- Shielded horizontal grab-bar handle

MODEL GUIDE					
Model No.	Overall Width	Grids	Cooking Area		Refrigeration
			Broiler	Griddle	Drawers
C45SHBPL/RB48-SC	48" (914mm)	3	35" x 27" (889 x 686mm)	42" x 28" (1067 x 711mm)	2ea 27-1/4" (692mm)

REFRIGERATION PACKAGE FEATURES:

-SC Self-Contained Models:

- Energy efficient hermetic compressor/condenser system
- Hot Gas Condensate System
- Coated evaporator coil by Turbo-Coil with 5 year warranty
- Digital thermostat temperature control
- 6' (1829mm) power cord with grounded NEMA 5-15P plug
- Compressor compartment on right end
- Condenser coil screen
- One-year standard parts and labor warranty, two years on compressor

HEAVY-DUTY DRAWER SYSTEM FEATURES:

- Full extension, 250 lbs (45 kg) individual drawer weight capacity
- Can accommodate up to 6" (152mm) deep, 12" x 20" (305 x 508mm) pans in top drawer and 4" (102mm) in the bottom drawer
- Heavy 14-gauge stainless steel track system
- Tandem 2" (51mm) diameter stainless steel wheels
- Recessed drawer handles
- Self closing drawers are easily removed for cleaning
- Removable magnetic drawer gaskets

STANDARD CONSTRUCTION FEATURES:

- Satin finish stainless steel front, sides and back
- Broiler interior high-temp aluminized finish
- Full width grease deflector under rollout grid
- Extra-large capacity removable grease drawer [for broiler]
- 3/4" NPT rear gas manifold connection
- Height-adjustable bullet feet
- Digital thermometer
- Interior liner is stainless steel with 1/4" (6mm) radius corners
- 2" (51mm) thick environmentally friendly, Non Ozone Depletion Potential, Non Global Warming Potential, high density polyurethane foam insulation
- 6" (152mm) height-adjustable stainless steel legs standard

AGENCY APPROVALS

- NSF Listed
- CSA Design Certified to ANSI Z83.11 • CSA 1.8
- Australian Gas Association Certification Number 7466
- CE Approved EN 203-1
- ETL
- UL Classified EPH-STD NSF-7



HDB-25 [Rev. 2/17]

LEGEND™ Heavy-Duty Gas Infrared, Overfired Broilers with Plancha Plate over Refrigerated Base

Item No. _____

Project _____

Quantity _____

C45SHPL/RB48-SC

Dimensions in brackets are millimeters

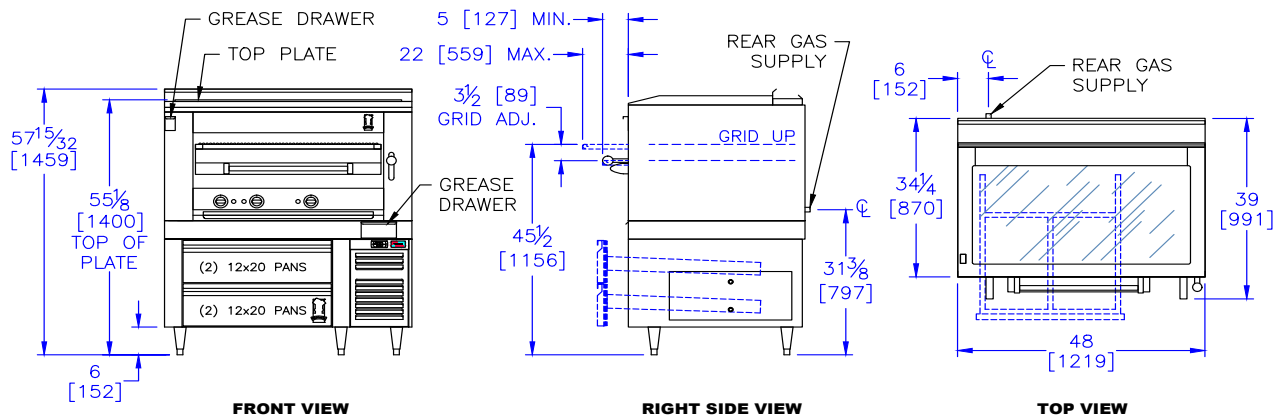

OPTIONS GUIDE:

General:

- Casters — set of four/six 5" (127 mm) casters
- Flex Connector Kit [3/4"] or [1"] NPT:
 - 3' (914mm) long
 - 4' (1219 mm) long
- Remote Refrigeration -R (see page RF-1)

International Approvals:

- CE-Conformite Europeene
Includes Flame Failure Valve Option
- AGA-Australian Gas Association
Includes Flame Failure Valve Option
- Canadian Approval

INSTALLATION REQUIREMENTS & SHIPPING INFORMATION

- Broilers must be installed in accordance with local codes or in their absence with the National Fuel Gas Code: ANSI Z22 3.1; CAN/CGA-B149.1 -Natural Gas and Propane Installation Code, as applicable. Compliance with codes is the responsibility of the Owner and Installer.
- An adequate ventilation system is required. Refer to National Fire Protection Association Standard No. 96, Standard for Ventilation Control and Fire Protection of Commercial Cooking Operations.
- This appliance is intended for commercial use by professionally trained personnel. NOT intended for Residential Use.
- Specify installation elevation: _____ if above 2000 feet (610m).
- GAS INLET SIZE (All Models): 3/4" NPT left-rear inlet. A 3/4" NPT gas pressure regulator is provided and must be installed (by others) when unit is connected to gas supply.
- The incoming gas line pressure into the regulator should be 8"-14" w.c. for natural gas, and 12"-14" w.c. for propane gas.
- Unit to be leveled and plumbed at installation for proper drain function.

Minimum Clearances	Combustible Construction	Noncombustible Construction
From Back Wall	6" (152 mm)	0"
Left & Right Side	6" (152 mm)	0"

Specify Type of Gas:	<input type="checkbox"/> Natural	<input type="checkbox"/> Propane	Refrigeration	HP*	Voltage	Phase	Amps	NEMA Plug	Shipping Weight	Shipping Class	
Manifold Pressure:	6.0" WC	10.0" WC	BTU/hr* (kW)								
Models:	Burners	BTU/hr* (kW)	BTU/hr* (kW)								
C45SHPL/RB48-SC	3	126,000 (36.9)	126,000 (36.9)	2040 (.60)	1/3	115	1	7.74	5-15P	1038	85



THE MONTAGUE COMPANY
 1830 Stearman Avenue, Hayward, CA 94545
 800 345-1830 • Fax: 510 785-3342
 www.montaguecompany.com

Due to continuous product improvements, specifications are subject to change without notice.



HDB-25 [Rev. 2/17]