

### 74 cu ft Freezers, Reach-In

- Improve the flow and function of your space by having frozen items where you need them most
- Comfortably fits 18" x 26" sheet pans (not included)
- Glass & solid door options
- 8 casters included (2 locking) for easy mobility
- LED lighting on glass door models



UCFZ585-SS71A



UCFZ585-SG71A

Model	Description	Voltage/Hz/Amps	Shipping Weight
UCFZ585-SS71A	Freezer, Reach-In, Solid Door	115v / 60hz / 20	650 lb
UCFZ585-SG71A	Freezer, Reach-In, Glass Door	115v / 60hz / 20	750 lb

#### Specifications

UCFZ585 dimensions: 83 15/32" H x 85 3/64" W x 31 15/32" D
AISI 304 stainless steel interior and exterior with locks
Autodefrost
CFC-free high-density polyurethane insulated cabinet
Electronic digital temperature control with alarms
Environmentally friendly R290 refrigerant: 2 x 3.5 oz (2 x 0.100kg)
Factory pre-wired for dedicated outlet, 11 ft. cord and plug included NEMA 5-20P
High efficiency compressor
High efficiency evaporator coil & condenser
NSF/ANSI Standard 7 compliant
Removable magnetic gasket for easy cleaning
Self-lubricating, sealed cast iron evaporator fan motor with high volume air flow design
Temperature range: -13°F to 14°F
Volume of 74 cu ft
3 sections, includes 9 epoxy coated wire shelves

Accessories	Description	Shipping Weight
ULA4080584	(1) Stainless steel shelf guide for all reach-ins except UCRE553 & UCFZ553, 24 3/4"	.88 lb
ULAQ32-0002	(1) Epoxy coated wire shelf, 20 7/8" x 25 5/8" for reach-ins	7 lb
ULA80110300	Interior LED lighting kit for solid door reach-ins	2.2 lb



**Product Specifications • 74 cu ft Freezers, Reach-In**

**Front (Closed - Solid Door)**

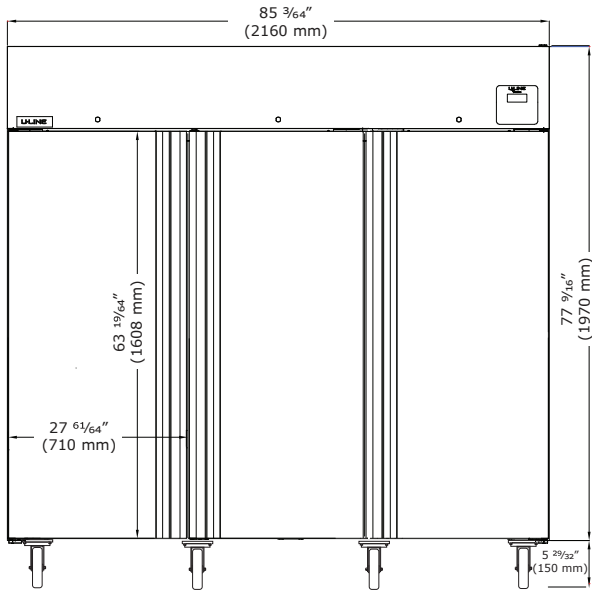

**Front (Open)**

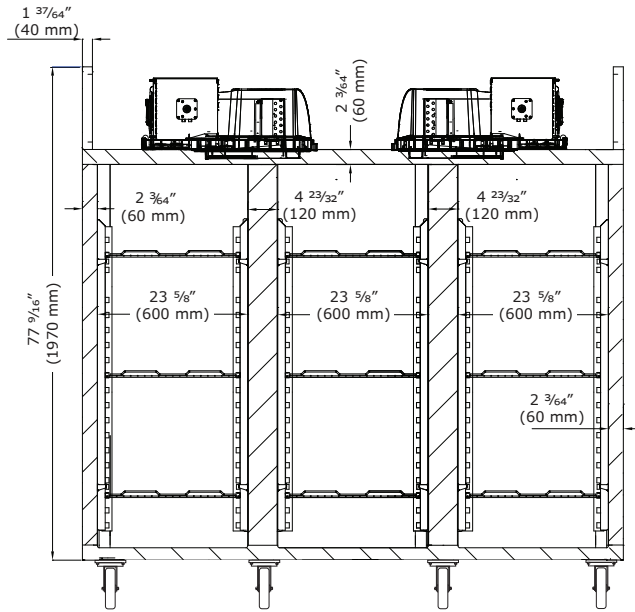

**Front (Closed - Glass Door)**

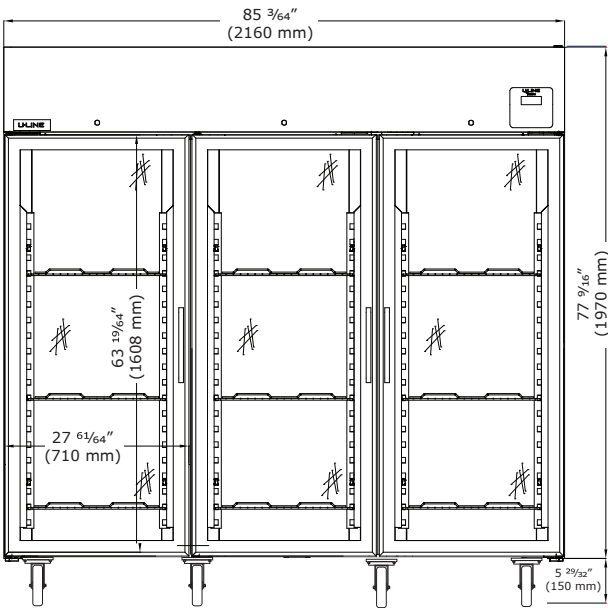

**Side**

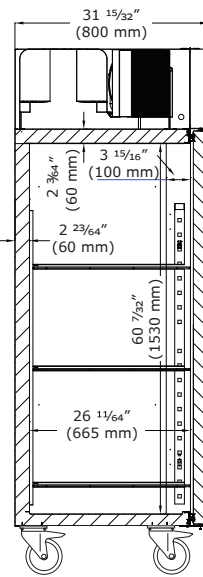

**Top**

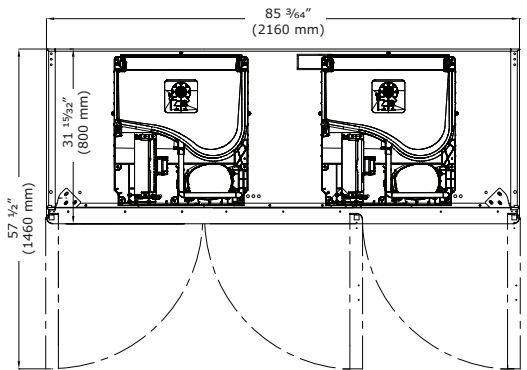

**Commercial Warranty**

3 Year (parts & labor) / 5 year sealed system (parts)  
See complete warranty for details

