



CREPE

CONCEPT

ELECTRIC CREPE MACHINES

- Crepe machines designed by people who invented crepes
- Cast iron plates with protective ceramic finish
- Electric crepe machines available with single and double plates
- Equipped with batter spreader
- Thermostatically controlled up to 570° F
- Integral on/off switch

VERSA

350E/400E

208/240v

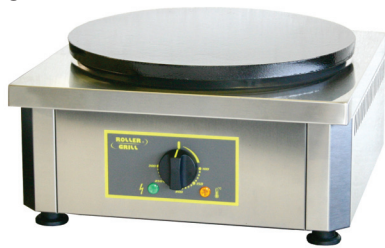

DIVERSA

400 ED

208/240v

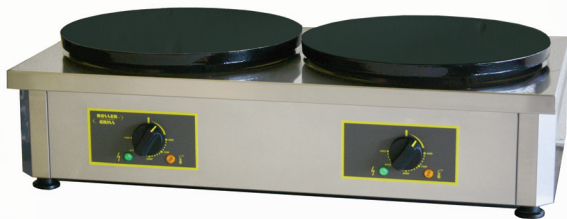

BATTER DISPENSER

CI-1



MOBILE CART

MC-04



DISCUS

350FE/400FE

120v or 208/240v



TRANSVERSA

400VC

208/240v



- Heavy duty vitroceramic cooking surface
- Infrared heat up to 570° F
- Ideal for reheating crepes, tortilla and quesadilla

CREPE KITS



WARM IT TOPPINGS DISPENSER



765 WESTMINSTER STREET PROVIDENCE, RI 02903
 TEL: (401)273-3300 FAX: (401)273-3328 E-mail: sales@equipex.com
 www.equipex.com





ELECTRIC CREPE MACHINES

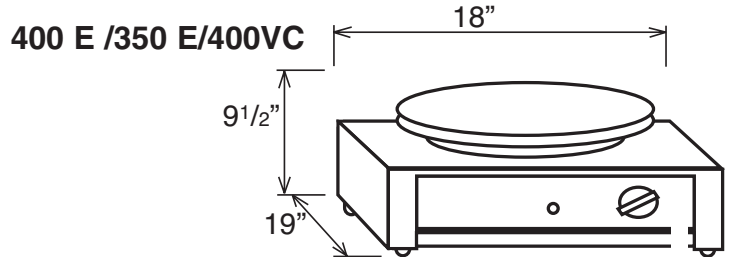
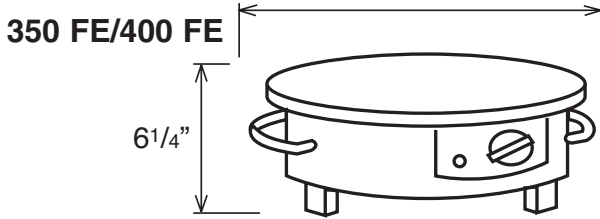
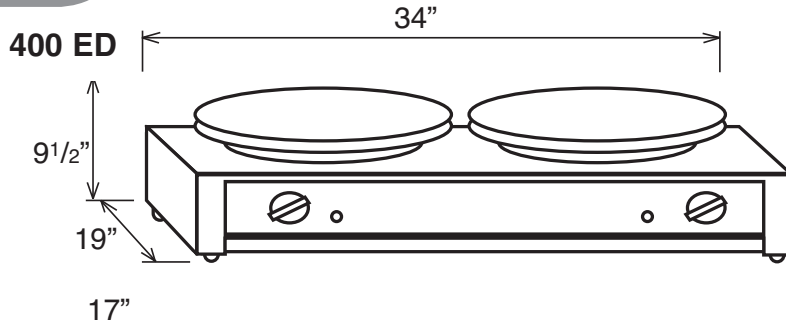

INSTALLATION CLEARANCE : 2" ALL SIDES AND BACK

SPECIFICATIONS

MODEL	ELECTRICAL	DIMENSIONS	WORK SURFACE	SHIPPING WEIGHT	NEMA PLUG
350FE	120V, 1PH 1.65KW, 14 Amps	17" diameter x 6 1/4"H	13 3/4" diameter	40 lbs	5-15 P
400FE	208/240V, 1PH 3.5KW, 13/15 Amps	17" diameter x 6 1/4"H	15 3/4" diameter	42 lbs	6-20 P
350 E	208/240V, 1PH 3.3KW, 12/14 Amps	18"Wx19"Dx9 1/2"H	13 3/4" diameter	45 lbs	6-20 P
400 E	208/240V, 1PH 3.9KW, 15/17 Amps	18"Wx19"Dx9 1/2"H	15 3/4" diameter	45 lbs	6-20 P
400 VC	208/240V, 1PH 2.5KW, 11/12 Amps	18"Wx19"Dx9 1/2"H	15 3/4"	36 lbs	6-15 P
400ED	208/240V, 1PH 7.9KW, 29/33 Amps	34"Wx19"Dx9 1/2"H	(2) 15 3/4" diameter	145 lbs	6-50 P
Warm It Drop In	120V, 1PH 170W, 1.5 Amps	7 3/4"Wx5 3/4"Dx8 1/2"H Cut Out: 6 1/2"Wx4 1/2"D	with (1) container	10 lbs	5-15 P
Warm It Countertop	120V, 1PH 170-340W, 1.5 Amps	8 1/2"Wx17"Dx10"H	with (1) or (2) containers	12 lbs	5-15 P
CK-1 ----- CK-3	S/S Casing, Water Vat, Batter Spreader, Spatula, (2) Bottles, Oil Spreader	24"Wx20"Dx6"H ----- 15 1/2"Wx6 1/4"Dx3 1/2"H	For 350FE Only ----- For All Models	12 lbs ----- 10 lbs	
CI-1	S/S Casing with Chill Well	15 1/2"Wx8"Dx10"H	10"Wx4"Dx5"H	10 lbs	
MC-04	120V, 1PH 500W, 4 Amps (Lighted Panel Only)	39.4"Wx23.6"Dx32.5"H		190 lbs	5-15 P

WARRANTY: Limited one year parts and labor



765 WESTMINSTER STREET PROVIDENCE, RI 02903
 TEL: (401)273-3300 FAX: (401)273-3328 E-mail: sales@equipex.com
 www.equipex.com