



BEVERAGE-AIR

Project: _____	AIA#
Item: _____	
Location: _____	SIS#
Approved: _____	

DW94HC DEEP WELL SERIES: HORIZONTAL BOTTLE COOLERS

HORIZONTAL BOTTLE COOLERS

DW94HC Deep Well Series
Hydrocarbon Series

MODEL:
DW94HC-S



7 Year Parts/Labor Warranty
7 Year Compressor Warranty

CABINET CONSTRUCTION

- Stainless steel exterior
- Galvanized steel interior and floor
- Full electronic control
- Tops include easy glide, stainless steel lids (4)
- Stainless steel countertop with integral glass stops
- Six (6) epoxy coated adjustable wire dividers
- Bottle opener and cap catcher standard
- Constructed with high cooling RPM fans to provide fast cooling

OPTIONS & ACCESSORIES

- Stainless steel interior
- Wire divider
- Lid locks
- 3" Casters or 6" adjustable leg with plate
- Remote option* (see note on back on page)

REFRIGERATION SYSTEM

- Refrigeration system uses R290 refrigerant to comply with all environmental concerns
- Automatic, non-electric defrost
- Epoxy coated evaporator coil
- Forced air refrigeration system holds product between 36°- 40°F



Please verify qualifying units by visiting:
www.energystar.gov/cfs

3779 Champion Blvd., Winston-Salem, NC 27105
1-888-845-9800 Fax: 1-336-245-6453
Beverage-Air.com Sales@bevair.com



BEVERAGE-AIR

MODEL	DW94HC-S
EXTERNAL DIMENSIONAL DATA	
Width Overall	95"
Depth Overall	26 5/8"
Depth Overall with Cap Catcher	27 7/8"
Height Overall	33 3/4"
Number of Lids	4
INTERNAL DIMENSIONAL DATA	
NET Capacity (cubic ft.)	28.63
Internal Width Overall (in)	90"
Internal Depth Overall (in)	22 3/4"
Internal Height Overall at Step (in)	16 3/4"
Internal Height Overall (in)	26 3/4"
Number of Dividers	6
12 oz. Bottle Capacity	39 Cases
12 oz. Can Capacity	55 3/4 Cases
ELECTRICAL DATA	
Full Load Amperes	2.5
REFRIGERATION DATA	
Horsepower	1/4
Capacity (BTU/Hr)	1702
Heat Rejection (BTU/Hr)	2553
Charge (lbs/grams/ounces)	0.2094 / 95 / 3.35
SHIPPING DATA	
Gross Weight - Crated	468 lbs
Height - Crated	41"
Width - Crated	98"
Depth - Crated	29"

*NOTE: Remote units are field wired and come with 6" legs.
Refrigerant must be specified at time of order.

We reserve the right to change specifications and product design without notice. Such revisions do not entitle the buyer to corresponding changes, improvements, additions or replacements for previously purchased equipment. Dimensional tolerances +/- 1/4". Metric dimensions (MM).

Horizontal Bottle Coolers - Deep Well Model: DW94HC-S

Model Views

Required Clearance: 3" Sides & Rear

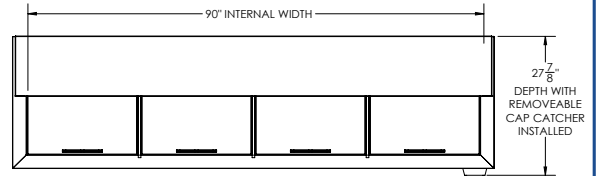

PLAN VIEW

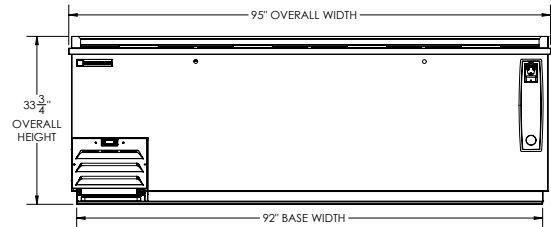

ELEVATION VIEW

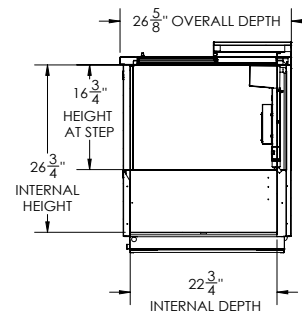

SIDE VIEW

ELECTRICAL CONNECTION



115/60/1
NEMA 5-15P

Unit pre-wired at factory and include 8' long cord and plug set.



3779 Champion Blvd., Winston-Salem, NC 27105 1-888-845-9800 Fax: 1-336-245-6453 Beverage-Air.com Sales@bevoir.com

