

Project: _____

Item: _____

Quantity: _____

Chicken Dolly



Specifically designed to stack iced or frozen food. This dolly keeps drips, spills, and condensation to a minimum with a sturdy removable drip pan.

- Framework is constructed out of 1" x 1" x .070" wall tubing.
- Laterals are constructed out of 1/2" x 1 1/4" oval tubing.
- Removable drip tray is constructed out of .063" aluminum sheet.
- Equipped with four 5" stem type swivel casters.
- Five-Year Guarantee against material defects and workmanship.
- Lifetime Guarantee against rust and corrosion.
- NSF Certified.

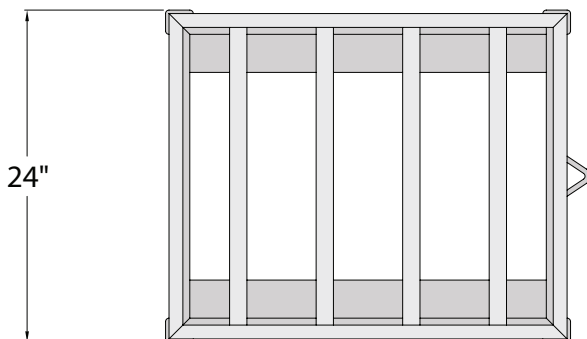
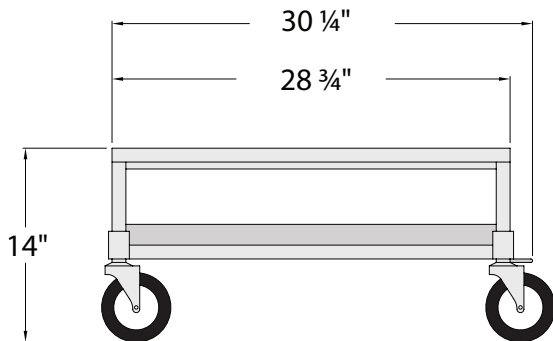

► Chicken Dolly

Model No.	Size W-H-D	Weight Capacity	Ship Lbs.
1187	24" x 14" x 30 1/4"	500 lbs.	24
Replacement Drip Pan - Not NSF Certified			
1188			5
Aluminum Drag Hook - Not NSF Certified.			
1199	37 1/2" Long		1

Four 5" stem type casters; two swivel, two with brake.

Comes equipped with drip pan.



1199



New Age Industrial Corp., Inc. || NewAgeIndustrial.com || Made in the USA

PO Box 520 • 16788 US Hwy 36 • Norton, Kansas 67654 || Phone: (800) 255-0104 • (785) 877-5121 || Fax: (877)-877-7687 • (785) 877-2616

This information is for general sales and engineering use only. New Age Industrial reserves the right to modify or make changes at any time, without notice, to materials and specifications.