

AT SERIES FOOD SHIELDS

Vertical Food Protector

Model AT1V

Quantity: _____ Item No: _____



- Finish:
- Brushed & Anodized Aluminum
 - Black Matte Powder Coat
 - Silver Powder Coat
 - Brushed Stainless Steel
 - _____

End Panels: (from customer side)

- Left - 18" deep
- Right - 18" deep
- _____

Height: (top glass edge to countertop)

- 24" - for 36" height counters
- 26" - for 34" height counters



DESCRIPTION

Vertical food protector for use on cooking stations, carving stations, or cafeteria counters.

1"Ø CNC machined solid supports

Clear tempered glass panels that meet or exceed ANSI Z97.1 standards.

A wide range of finish options are available to match any décor.

Exceptional construction – all components CNC machined in the USA for years of service. Modular design and machined componentry allows for changes or additions at a later date.

Produced, finished and assembled in the USA.

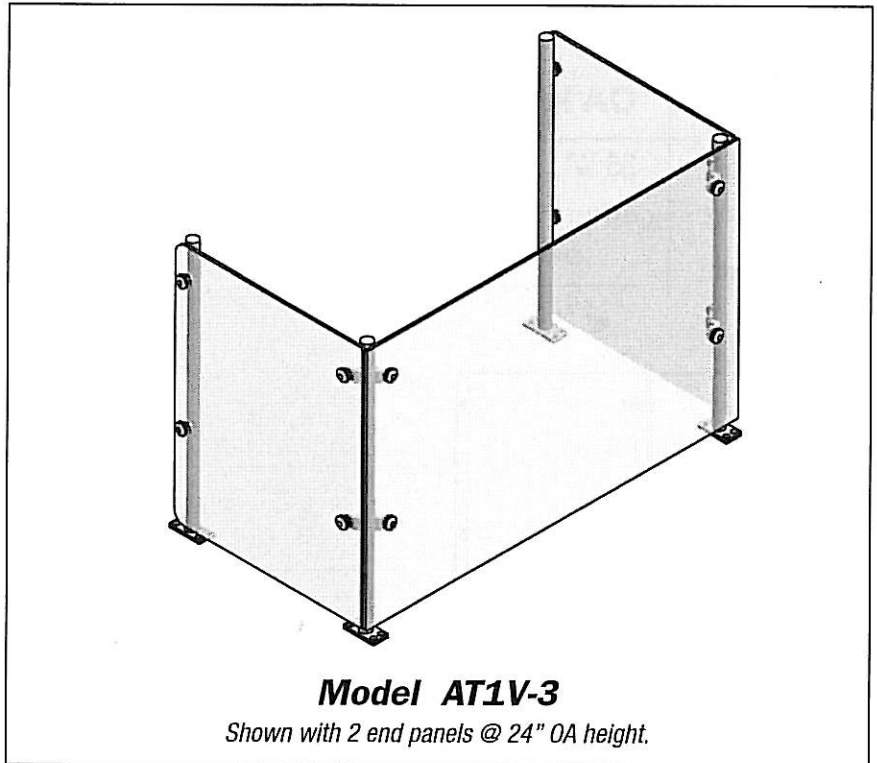

Model AT1V-3

Shown with 2 end panels @ 24" OA height.

VERSA-GARD®
Copyright © Versa-Gard, 2010

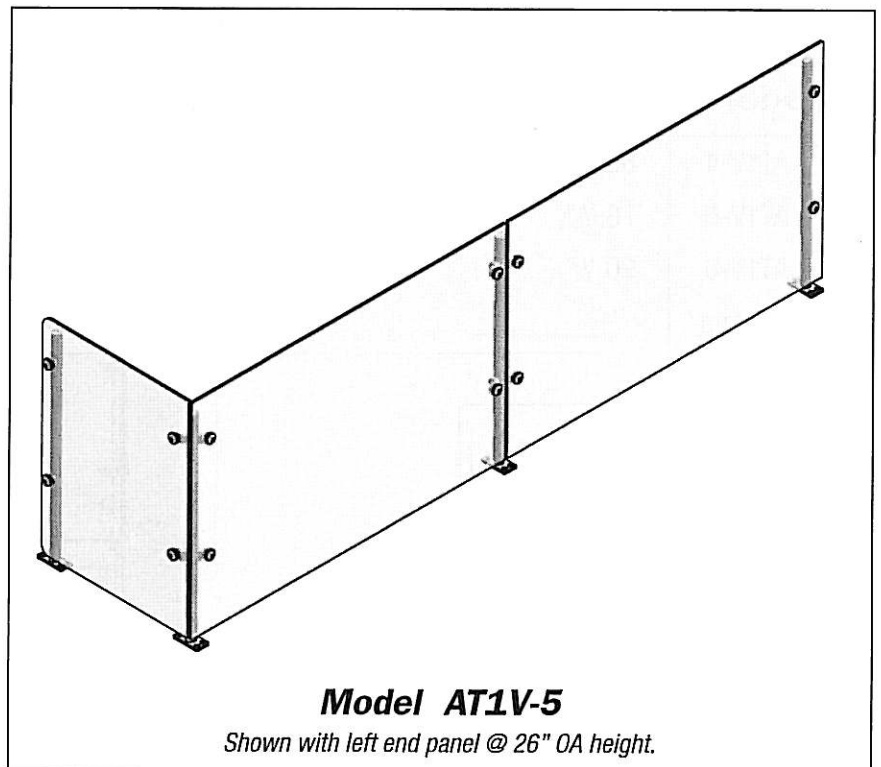

Model AT1V-5

Shown with left end panel @ 26" OA height.

Vertical Food Protector

Model	OA length (L1)
<input type="checkbox"/> AT1V-2	35 1/4"
<input type="checkbox"/> AT1V-3	49"
<input type="checkbox"/> Custom	_____

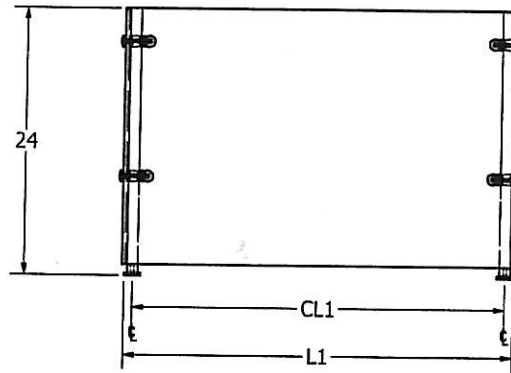
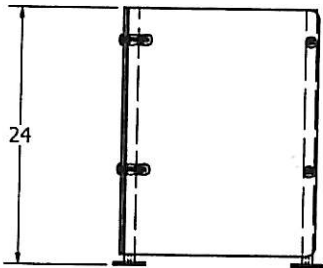
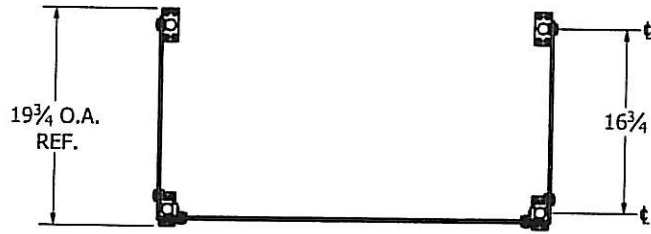

VERSA-GARD®
Copyright © Versa-Gard, 2010



Shown with 2 end panels @ 24" OA height.

Model	OA length (L2)
<input type="checkbox"/> AT1V-4	62 3/4"
<input type="checkbox"/> AT1V-5	76 1/2"
<input type="checkbox"/> AT1V-6	90 1/4"
<input type="checkbox"/> Custom	_____

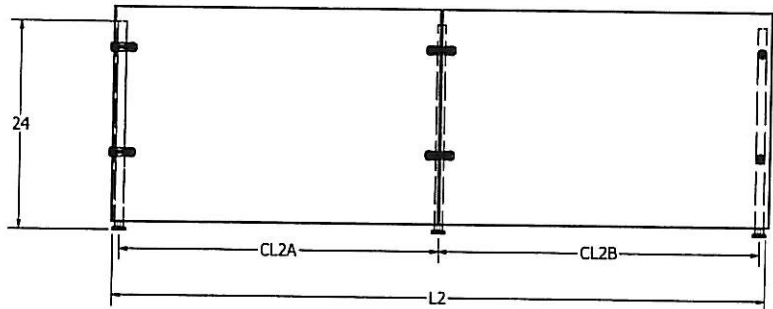
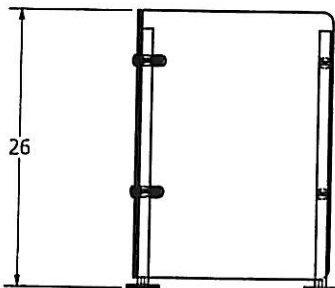
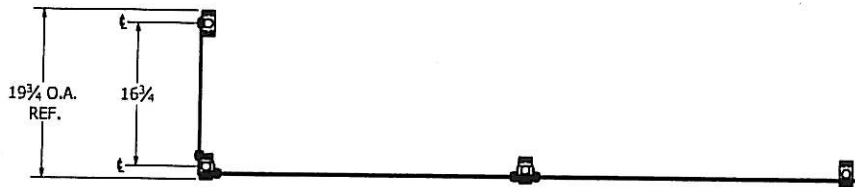

Shown with left end panel @ 26" OA height.