



Profit from the Eagle Advantage®

# Specification Sheet

## Short Form Specifications

Eagle Pizza Prep Area, model TSPP2460Z, to consist of 24" x 60" worktable with 14 gauge stainless steel tabletop, 4 1/2" backsplash, galvanized legs and galvanized adjustable undershelf. Wall-mounted 30"-tall vertical uprights and 33" x 54" grid panel accommodate standard items: 14" brackets and 14" x 54" wire overshelf, three display hooks, four 1/3-size pans, and three spice racks.

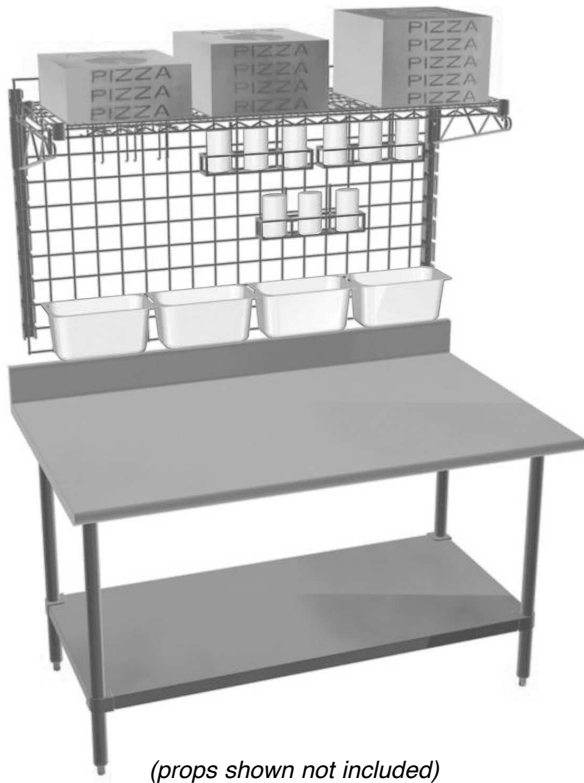

(props shown not included)

Item No.:	_____
Project No.:	_____
S.I.S. No.:	_____

## Pizza Prep Area

### MODELS:

TSPP2460Z

- Standard components create a customized look.
- Keeps task-related items together.
- 24" x 60" (610 x 1524mm) table features 14 gauge type 304 stainless steel tabletop with 4 1/2" (114mm) backsplash, galvanized legs and galvanized adjustable undershelf.
- 34" (864mm) working height, 38 1/2" (978mm) overall height.
- 30" (762mm)-tall vertical zinc-plated wall uprights.
- 33"-tall x 54"-long (838 x 1372mm) zinc-plated wall-mounted grid panel.
- 14" (356mm) brackets support 14" x 54" (356 x 1372mm) zinc-plated wire overshelf with patented QuadTruss® design (patent #5,390,803).
- Four 1/3-size pans: 12 5/8"-long x 6 7/8"-wide x 4"-deep (321 x 175 x 102mm), 4 1/4-quart capacity.
- Three 6" (152mm)-long merchandise display hooks made of chrome-plated 1/4"-diameter wire.
- Three 14" (356mm)-long spice racks made of 6-gauge zinc-plated wire.

### EAGLE GROUP

100 Industrial Boulevard, Clayton, DE 19938-8903 USA  
 Phone: 302-653-3000 • 800-441-8440 • Fax: 302-653-2065  
[www.eaglegrp.com](http://www.eaglegrp.com)  
[www.eaglegrpnews.com](http://www.eaglegrpnews.com)  
[www.eaglemhc.com](http://www.eaglemhc.com)

For custom configuration or fabrication needs, contact our SpecFAB® Division.  
 Phone: 302-653-3000 • Fax: 302-653-2065 • e-mail: [quotes@eaglegrp.com](mailto:quotes@eaglegrp.com)



EG01.54 Rev. 06/23

Spec sheets available for viewing, printing or downloading from our online literature library at our websites

Eagle Foodservice Equipment, Eagle MHC, and SpecFAB® are divisions of Eagle Group. ©2023 by the Eagle Group



Item No.: \_\_\_\_\_  
 Project No.: \_\_\_\_\_  
 S.I.S. No.: \_\_\_\_\_

# Pizza Prep Area

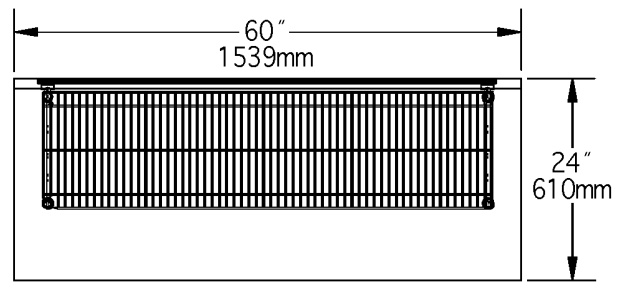

TOP VIEW

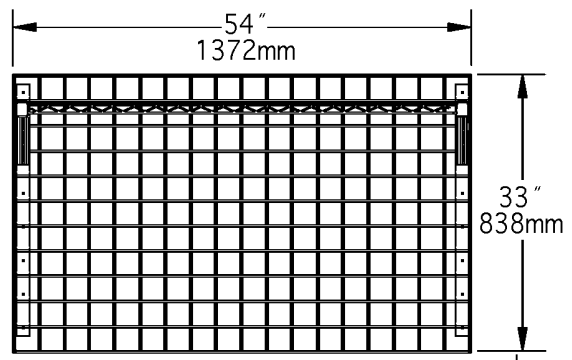

FRONT VIEW

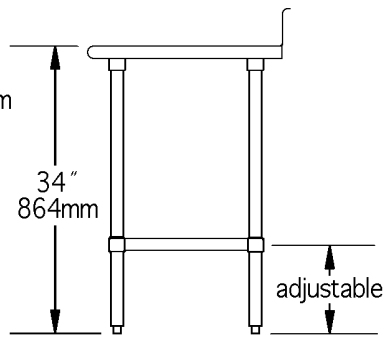
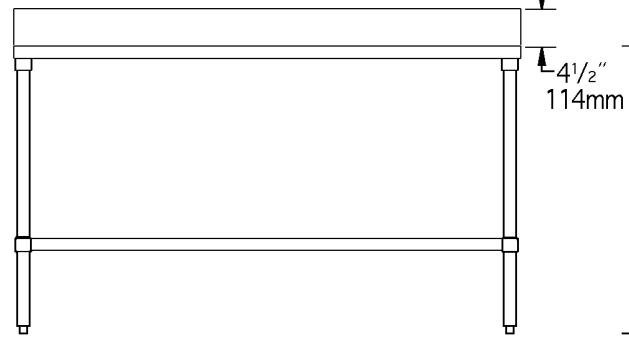
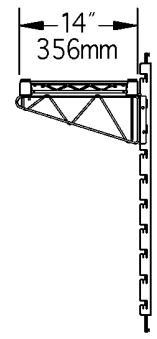

SIDE VIEW

model #	overall table dimensions						wall grid dimensions*				total weight	
	width		length		height		height		width		lbs.	kg
	in.	mm	in.	mm	in.	mm	in.	mm	in.	mm		
<b>TSP2460Z</b>	24"	610	60"	1524	38 1/2"	978	33"	838	54"	1372	113	51.3

\* Excludes wire overshelf and brackets.

**EAGLE GROUP**  
 100 Industrial Boulevard, Clayton, DE 19938-8903 USA  
 Phone: 302-653-3000 • Fax: 302-653-2065  
 www.eaglegrp.com

Foodservice Division: Phone 800-441-8440  
 MHC/Retail Display Divisions: Phone 800-637-5100

Printed in U.S.A.  
 ©2010 by Eagle Group  
 Rev. 06/23

**Spec sheets available for viewing, printing or downloading from our online literature library at [www.eaglegrp.com](http://www.eaglegrp.com)**

Although every attempt has been made to ensure the accuracy of the information provided, we cannot be held responsible for typographical or printing errors. Information and specifications are subject to change without notice. Please confirm at time of order.