

49 cu ft Freezers, Reach-In

- Improve the flow and function of your space by having frozen items where you need them most
- Comfortably fits 18" x 26" sheet pans (not included)
- Glass & solid door options
- 6 casters included (2 locking) for easy mobility
- LED lighting on glass door models



UCFZ553-SS71A



UCFZ553-SG71A

Model	Description	Voltage/Hz/Amps	Shipping Weight
UCFZ553-SS71A	49 cu ft Freezer Solid Door, Reach-In	115v / 60hz / 9.6	441 lb
UCFZ553-SG71A	49 cu ft Freezer Glass Door, Reach-In	115v / 60hz / 9.6	617 lb

Specifications

UCFZ553-SS71A dimensions: 82 9/32" H x 52 9/16" W x 31 1/2" D
UCFZ553-SG71A dimensions: 82 9/32" H x 52 9/16" W x 31 1/2" D
AISI 304 Stainless steel interior and exterior with locks
Autodefrost
CFC-free high-density polyurethane insulated cabinet
Electronic digital temperature control with alarms
Environmentally friendly R290 refrigerant - 4.2 oz (0.120kg)
Factory pre-wired for dedicated outlet, 11 ft cord and plug included NEMA 5-15P
High efficiency evaporator coil & condenser
High efficiency top-mounted compressor with 9.6 running amps
LED lighting
NSF/ANSI Standard 7 compliant
Removable magnetic gasket for easy cleaning
Self-lubricating, sealed cast iron evaporator fan motor with high volume air flow design
Temperature range: -13°F to 14°F
Volume of 49 cu ft
2 sections, includes 6 epoxy coated wire shelves

Accessories	Description	Shipping Weight
ULA4080534	(1) Stainless steel embossed shelf guide for UCRE553 & UCFZ553 reach-ins, 22"	.88 lb
ULAQ32-0002	(1) Epoxy coated wire shelf, 20 7/8" x 25 5/8" for reach-ins	7 lb
ULA80110300	Interior LED lighting kit for solid door reach-ins	2.2 lb



Product Specifications • 49 cu ft Freezers, Reach-In

**Front
(Closed - Solid Door)**

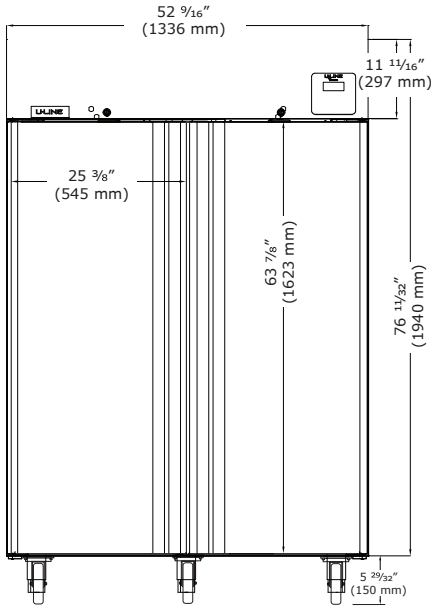

**Front
(Closed - Glass Door)**

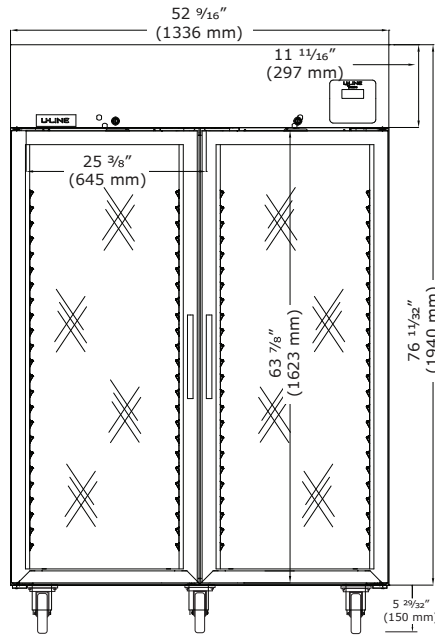

Side

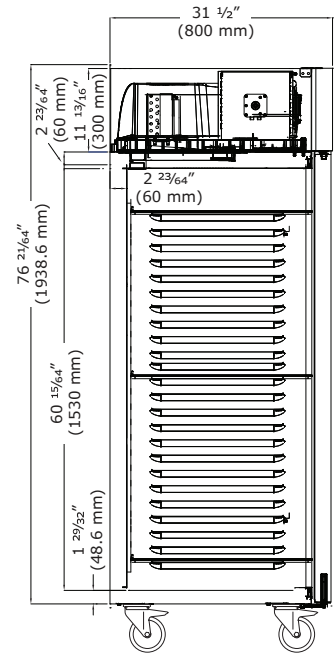

Top

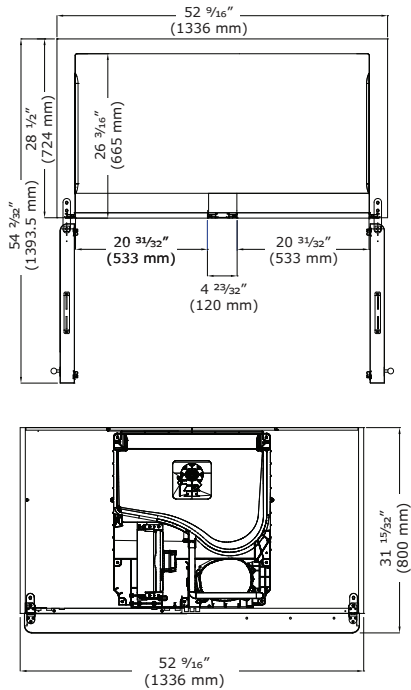

Back

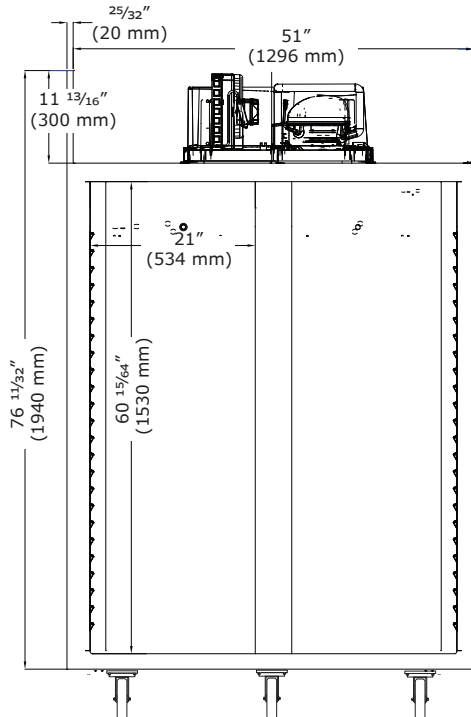

Side

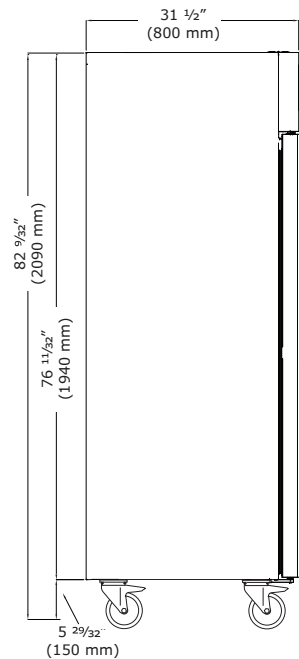

Commercial Warranty

3 Year (parts & labor) / 5 year sealed system (parts)
See complete warranty for details

