

FXI-11 SYSTEM

FOODSERVICE WATER TREATMENT SYSTEM

FXI-11: 160-50105

Replacement Cartridge: CTOS-10 252-00310



APPLICATIONS

- ◆ Ice
- ◆ Coffee
- ◆ Steam & combi ovens

FEATURES • BENEFITS

- ◆ IsoNet®, Pentair Everpure's patented scale-inhibiting technology, helps protect equipment against scale and corrosion for the rated capacity of the system
- ◆ Reduces maintenance frequency and cost, and extends equipment life
- ◆ Gradient-density sediment filtration protects against dirt, rust and other debris down to 0.5 microns
- ◆ High-capacity activated-carbon filtration makes water taste great and protects equipment against corrosive chlorine
- ◆ Sturdy mounting bracket and full-flow inlet shutoff valve simplify installation
- ◆ Built-in pressure gauge allows visual monitoring of when filters need to be changed
- ◆ Inlet shutoff and depressurization valves make filter replacement quick and simple
- ◆ Minimizes waste by only replacing drop-in cartridge and reusing filter sump
- ◆ NSF Certified under Standard 42

INSTALLATION TIPS

- ◆ Feed-water connection to system should be COLD only.
- ◆ Do not exceed system specifications for temperature and pressure.
- ◆ Allow 3" clearance below system for filter housing removal and cartridge replacement.
- ◆ Connect filtered water line to ice and steam production connections only. Do not use for condenser water.
- ◆ Detailed installation, operation and maintenance manual included with each system.

OPERATION TIPS

- ◆ Change cartridges on a regular six (6) month preventative maintenance program.
- ◆ Change cartridges when capacity is reached or when flow becomes too slow.
- ◆ Always flush the filter cartridge at time of installation and cartridge change.

SIZING

- ◆ Service Flow Rate: 1.5 gpm (5.7 lpm)
- ◆ Rated Capacity: 15,000 gals. (56,775 L)

FXI-11 SYSTEM

160-50105

FXI-11: 160-50105
Replacement Cartridge: CTOS-10 252-00310

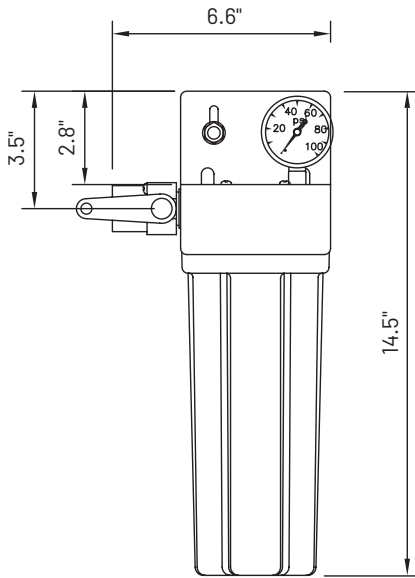

SPECIFICATIONS

- ◆ **Service Flow Rate**
Maximum 1.5 gpm (5.7 Lpm)
- ◆ **Rated Capacity**
15,000 gallons (56,775 L)
- ◆ **Pressure Requirements**
10 – 125 psi (0.7 – 8.6 bar), non-shock
- ◆ **Temperature**
35 – 100°F (2 – 38°C)
- ◆ **Overall Dimensions**
14.5" L x 6.6" W x 5.1" D
36.3 cm x 16.8 cm x 13.0 cm
- ◆ **Inlet Connection**
Inlet Connection: 1/2" FNPT
- ◆ **Outlet Connection**
Outlet Connection: 1/2" FNPT
- ◆ **Shipping Weight**
6 lbs (2.7 kgs)
- ◆ **Electrical Connection**
None required



System Tested and Certified by NSF International against NSF/ANSI Standard 42:

AESTHETIC EFFECTS
Chemical Reduction
Taste & Odor
Chlorine
Mechanical Filtration
Nominal Particulate Class I

WARRANTY

Everpure water treatment systems by Pentair (excluding replaceable elements) are covered by a limited warranty against defects in material and workmanship for a period of five years after date of purchase. Everpure replaceable elements (filter cartridges and water treatment cartridges) are covered by a limited warranty against defects in material and workmanship for a period of one year after date of purchase. See printed warranty for details. Pentair will provide a copy of the warranty upon request.

The contaminants or other substances removed or reduced by this drinking water system are not necessarily in your water. Do not use with water that is microbiologically unsafe or of unknown quality without adequate disinfection before or after the system.

Since the conditions under which our products may be used are beyond our control, we cannot accept any liability with respect to the improper installation, application and/or use of our products.



United States | 1040 Muirfield Drive | Hanover Park, IL 60133 | 800.942.1153 (US Only) 630.307.3000 Main | cseverpure@pentair.com | foodservice.pentair.com
Australia | 1-21 Monash Drive | Dandenong South, Vic 3175 | Australia | 011.1300 576 190 Tel | au.everpure@pentair.com
China | 21F Cloud 9 Plaza, NO 1118 | Shanghai, 200052 | China | 86.21.3211.4588 Tel | china.water@pentair.com
India | Boulevard, B-9/A, 7th Floor - Tower B Sector 62 | Noida - 201301 | 91.120.419.9444 Tel | indiacustomer@pentair.com
Europe | Pentair Water Belgium BVBA | Industriepark Wolfstee, Toekomstlaan 30, B-2200 Herentals | Belgium | +32.(0).14.283.504 Tel | sales@everpure-europe.com
Japan | Japan Inc. | Hashimoto MN Bldg. 7F, | 3-25-1 Hashimoto, Midori-ku, Sagami-hara-shi | Kanagawa 252-0143 | Japan | 81.(0)42.775.3011 Tel | info@everpure.co.jp
Southeast Asia | 390 Havelock Road, | #04-01 King's Centre | Singapore 169662 | 65.6768.5800 Tel | cseverpure@pentair.com

All indicated Pentair trademarks and logos are property of Pentair. Third party registered and unregistered trademarks and logos are the property of their respective owners. Because we are continuously improving our products and services, Pentair reserves the right to change specifications without prior notice. Pentair is an equal opportunity employer.