

## "EBOS6" ENCLOSED BASE WORK TABLES

### 16GA Stainless Steel Top - Open Front

#### FEATURES:

- 16GA Stainless Steel Flat Top
- Open Base Style
- Type 300 Stainless Steel With #4 Polish, Satin Finish
- Top Is Sound Deadened
- Reinforced With 1"x2" Channel Running Entire Length Of Table
- 1-1/2" Stallion Edge On Front And Rear With Side Edges 90 Degree Bend Down For Table Line-Up
- Stainless Steel Base And Undershelf
- Undershelf Is Secured In A Fixed Position, 10" Above Floor
- Shipped Standard Welded Set-Up
- "EBWS" Welded Intermediate Shelves Available

#### SPECIFICATIONS:

- Top: Stainless Steel Tops Are TIG Welded, Exposed Welds Are Polished To Match Adjacent Surface
- Top: 16GA Stainless Steel Type 300 Stainless Steel With #4 Polish, Satin Finish
- Shelf: 18GA Type 300 Stainless Steel, #4 Polish With Satin Finish
- Legs: 1-1/2" Square O.D., 16GA Tubular Stainless Steel
- Panels: 20GA Type 300 Stainless Steel, #4 Polish With Satin Finish
- Feet: 1" Adjustable Stainless Steel Bullet Feet



EBOS6-3072

#### CERTIFICATIONS:



### ACCESSORIES

MODEL	DESCRIPTION
EBWS	Welded Intermediate Shelf - All Sizes

### "EBOS6" ENCLOSED BASE WORK TABLES

LENGTH	# OF LEGS	24" WIDTH	WEIGHT (LBS)	30" WIDTH	WEIGHT (LBS)
36"	4	EBOS6-2436	130	EBOS6-3036	140
48"	4	EBOS6-2448	150	EBOS6-3048	165
60"	4	EBOS6-2460	170	EBOS6-3060	190
72"	4	EBOS6-2472	195	EBOS6-3072	220
84"	6	EBOS6-2484	220	EBOS6-3084	247
96"	6	EBOS6-2496	250	EBOS6-3096	274
108"	6	EBOS6-24108	273	EBOS6-30108	300
120"	6	EBOS6-24120	295	EBOS6-30120	326
132"	6	EBOS6-24132	320	EBOS6-30132	352
144"	6	EBOS6-24144	345	EBOS6-30144	378

ALL DIMENSIONS ARE TYPICAL. TOLERANCE +/- .500". JOHN BOOS & CO. RESERVES THE RIGHT TO CHANGE SPECIFICATIONS WITHOUT NOTICE.

# DETAILED SPECIFICATIONS

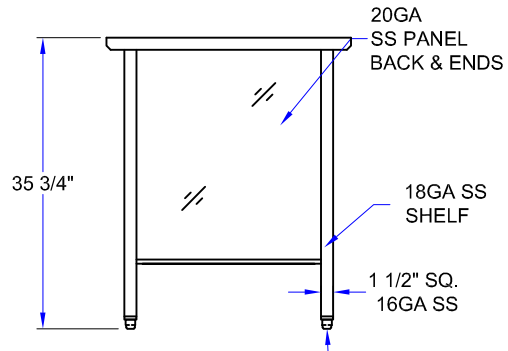
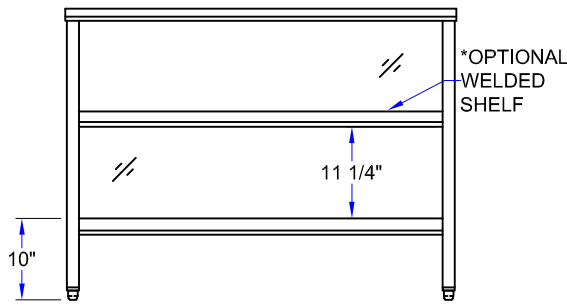
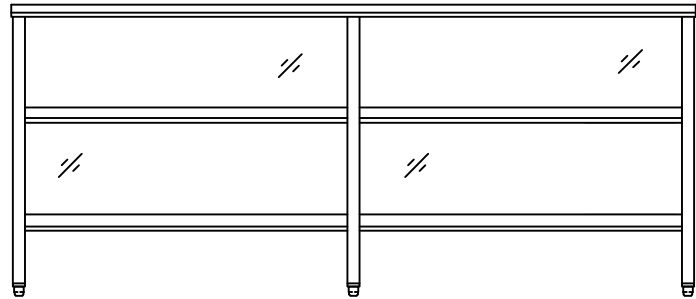
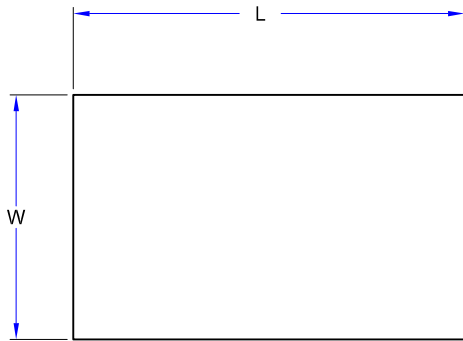

## MODEL # STRUCTURE

S = Stainless Steel  
 O = Open Front  
 EB = Enclosed Base

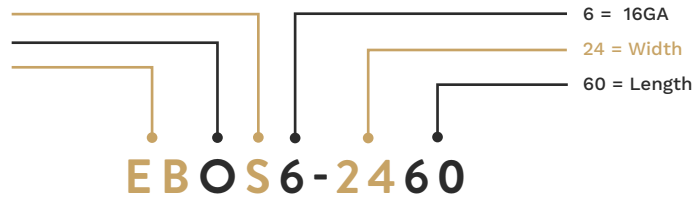

## "EBOS6" ENCLOSED BASE WORK TABLES

LENGTH	# OF LEGS	24" WIDTH	WEIGHT (LBS)	30" WIDTH	WEIGHT (LBS)
36"	4	EBOS6-2436	130	EBOS6-3036	140
48"	4	EBOS6-2448	150	EBOS6-3048	165
60"	4	EBOS6-2460	170	EBOS6-3060	190
72"	4	EBOS6-2472	195	EBOS6-3072	220
84"	6	EBOS6-2484	220	EBOS6-3084	247
96"	6	EBOS6-2496	250	EBOS6-3096	274
108"	6	EBOS6-24108	273	EBOS6-30108	300
120"	6	EBOS6-24120	295	EBOS6-30120	326
132"	6	EBOS6-24132	320	EBOS6-30132	352
144"	6	EBOS6-24144	345	EBOS6-30144	378

ALL DIMENSIONS ARE TYPICAL. TOLERANCE +/- .500". JOHN BOOS & CO. RESERVES THE RIGHT TO CHANGE SPECIFICATIONS WITHOUT NOTICE.