



Profit from the Eagle Advantage®

Specification Sheet

Short Form Specifications

Eagle Deluxe Series Filler Table, model _____.
 Tabletop is 16/304 stainless steel with rolled edge on front, sides turned down, and 1½" upturn on rear. Constructed with "uni-lok" patented gusset system with the gussets recessed into the hat channels to reduce lateral movement. 1½" O.D. galvanized tubular legs with 1¼" stainless steel cross rails and adjustable stainless steel flanged feet or bullet feet.

Eagle Spec-Master® Series Filler Table, model _____.
 Tabletop is 14/304 stainless steel with rolled edge on front, sides turned down and 1½" upturn on rear. Constructed with "uni-lok" patented gusset system with the gussets recessed into the hat channels to reduce lateral movement. 1½" O.D. stainless steel tubular legs with 1¼" stainless steel tubular cross rails, and adjustable stainless steel flanged feet or bullet feet.

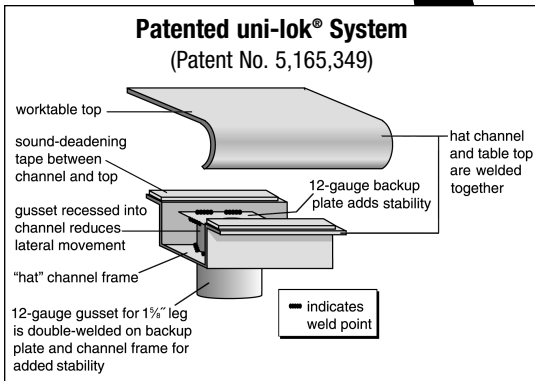
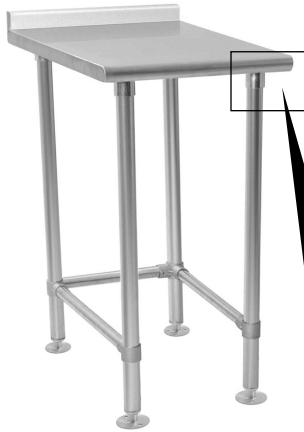

EAGLE GROUP
 100 Industrial Boulevard, Clayton, DE 19938-8903 USA
 Phone: 302-653-3000 • 800-441-8440 • Fax: 302-653-2065
www.eaglegrp.com
www.eaglegrpnews.com
www.eaglemhc.com

For custom configuration or fabrication needs, contact our **SpecFAB® Division**.
 Phone: 302-653-3000 • Fax: 302-653-2065 • e-mail: quotes@eaglegrp.com

Item No.: _____
 Project No.: _____
 S.I.S. No.: _____

Filler Tables with Rear Upturn

MODELS:

- | | | |
|--|--|--|
| <input type="checkbox"/> UT2412STE | <input type="checkbox"/> UT3012STE | <input type="checkbox"/> UT3612STE |
| <input type="checkbox"/> UT2412STEB | <input type="checkbox"/> UT3012STEB | <input type="checkbox"/> UT3612STEB |
| <input type="checkbox"/> UT2415STE | <input type="checkbox"/> UT3015STE | <input type="checkbox"/> UT3615STE |
| <input type="checkbox"/> UT2415STEB | <input type="checkbox"/> UT3015STEB | <input type="checkbox"/> UT3615STEB |
| <input type="checkbox"/> UT2418STE | <input type="checkbox"/> UT3018STE | <input type="checkbox"/> UT3618STE |
| <input type="checkbox"/> UT2418STEB | <input type="checkbox"/> UT3018STEB | <input type="checkbox"/> UT3618STEB |

Tabletop

- Top reinforced with welded-on hat channel.
- Sound-deadened between top and channels.
- 1½" (38mm) 90° rear upturn with radius at intersection.
- 1½" (38mm)-diameter 180° rolled edge on front. Ends are turned down 90° providing for flush installations when required.
- Deluxe Series: 16 gauge type 304 polished stainless steel.
- Spec-Master® Series: 14 gauge type 304 polished stainless steel.

Crossbracing—1¼" (38mm)-diameter

- Heavy gauge type 304 stainless steel.
- Front-to-back and side-to-side.
- Aluminum castings join crossbraces, legs and rear brace.

Legs—1½" (41mm)-diameter

- Patented uni-lok® gusset system (patent #5,165,349): gussets are recessed into hat channel, reducing lateral movement.
- Heavy gauge stainless steel.
- Deluxe Series: Galvanized gussets.
- Spec-Master® Series: Stainless steel gussets and stainless steel hat channels.
- All 12' and 15' (305 and 381mm)-long tables feature stainless steel adjustable flanged feet.
- All 18' (457mm)-long tables feature stainless steel adjustable bullet feet.

Options / Accessories

- Undershef
- Side upturns

Note: Filler tables are not designed to stand alone or to hold heavy equipment loads. Application and safe installation are the responsibility of the end user.

Certifications / Approvals



Spec sheets available for viewing, printing or downloading from our online literature library at our websites



Item No.: _____
 Project No.: _____
 S.I.S. No.: _____

Filler Tables with Rear Upturn

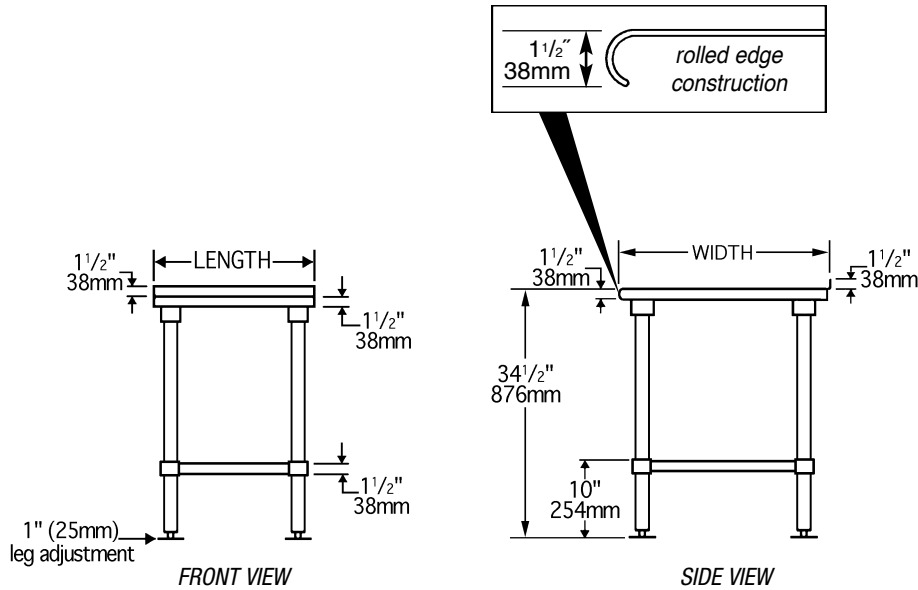

| DELUXE SERIES model # | SPEC-MASTER® SERIES model # | # of legs | width | | length | | weight * | |
|-----------------------------|-----------------------------------|--------------|-------|-----|--------|-----|----------|------|
| | | | in. | mm | in. | mm | lbs. | kg |
| UT2412STEB | UT2412STE | 4 | 24" | 610 | 12" | 305 | 30 | 13.6 |
| UT2415STEB | UT2415STE | 4 | 24" | 610 | 15" | 381 | 34 | 15.4 |
| UT2418STEB | UT2418STE | 4 | 24" | 610 | 18" | 457 | 36 | 16.3 |
| UT3012STEB | UT3012STE | 4 | 30" | 762 | 12" | 305 | 34 | 15.4 |
| UT3015STEB | UT3015STE | 4 | 30" | 762 | 15" | 381 | 36 | 16.3 |
| UT3018STEB | UT3018STE | 4 | 30" | 762 | 18" | 457 | 40 | 18.1 |
| UT3612STEB | UT3612STE | 4 | 36" | 914 | 12" | 305 | 37 | 16.8 |
| UT3615STEB | UT3615STE | 4 | 36" | 914 | 15" | 381 | 40 | 18.1 |
| UT3618STEB | UT3618STE | 4 | 36" | 914 | 18" | 457 | 45 | 20.4 |

* On Spec-Master® tables, increase stated weight by 10%.

EAGLE GROUP

100 Industrial Boulevard, Clayton, DE 19938-8903 USA

Phone: 302-653-3000 or 800-441-8440 • Fax: 302-653-2065

www.eaglegrp.com • www.eaglegrpnews.com • www.eaglehmc.com

Printed in U.S.A.
 ©2023 by Eagle Group

Rev. 07/23

Spec sheets available for viewing, printing or downloading from our online literature library at our websites

Although every attempt has been made to ensure the accuracy of the information provided, we cannot be held responsible for typographical or printing errors. Information and specifications are subject to change without notice. Please confirm at time of order.