

Garland Induction Built-in Heat Retaining Unit RTCSmp Install Hold-Line

Models

- GI-HO/IN 3200



Modular induction built-in concept consisting of:
 Induction generator, 1-2 control units and 1-4 heat retaining plates. Equipped with the latest RTCSmp (Realtime temperature control system) technology.

Standard Features

Induction generator:

A generator, developed specifically for heat retaining/holding, built in an aluminum enclosure, which includes an integrated air fan and connectors in the front of the housing, that are completely protected against impacts. All connections, such as mains cable, plugs for control units, coil connection and temperature sensors are accessible from the outside.

Fresh air is supplied by the fan, located at the bottom of the unit. The unit is also equipped with an air guiding system that directs the hot air out of the housing on its left and right side. With this system, a recirculation of exhausted air is not possible.

Heat retaining plate:

The heat retaining plate is equipped with the latest RTCSmp sensor technology which enables temperature controls in real-time. The set temperature is displayed via a 7-segment display underneath the Ceran glass. The heat retaining plate includes three (3) temperature sensors as well as the connectors for the coils and the sensors. Thanks to a space saving and compact design construction of the heat retaining plate, stand alone installations in shallow cabinets are possible.

Control unit:

The control unit consists of a chrome sheet metal cover with a built in power switch. The power switch is enclosed in a polymer housing, with high resistance to external impacts. The control unit is connected with the generator via an RJ45 cable. The control unit regulates the temperature in an increment of 1°C and this from 122-212°F (50 to 100°C). The set temperature and the current temperature are shown via the 7-segment display that is located underneath the Ceran.

Safety above all:

- RTCSmp electronic temperature control that monitors the state of the induction coil, power board, CPU and the Ceran glass temperature.
- RTCSmp monitors the energy supply
- No Pan No Heat - Only if an induction suitable pan is located on the glass that energy will be consumed.

Optional Features

- Optional induction ready holding pans available contact your dealer for sizes and prices.

CE models comply with the latest European Norms:
 EN 60335-1, EN 60335-2-36, EN 62233 (EMC/EMV)

North American models:
 ETL listed in compliance with UL 197, CSA C22.2 No.109, NSF-4
 Complies with FCC part 18, ICES-001

Garland Induction Built-in Heat Retaining Unit RTCSmp Install Hold-Line

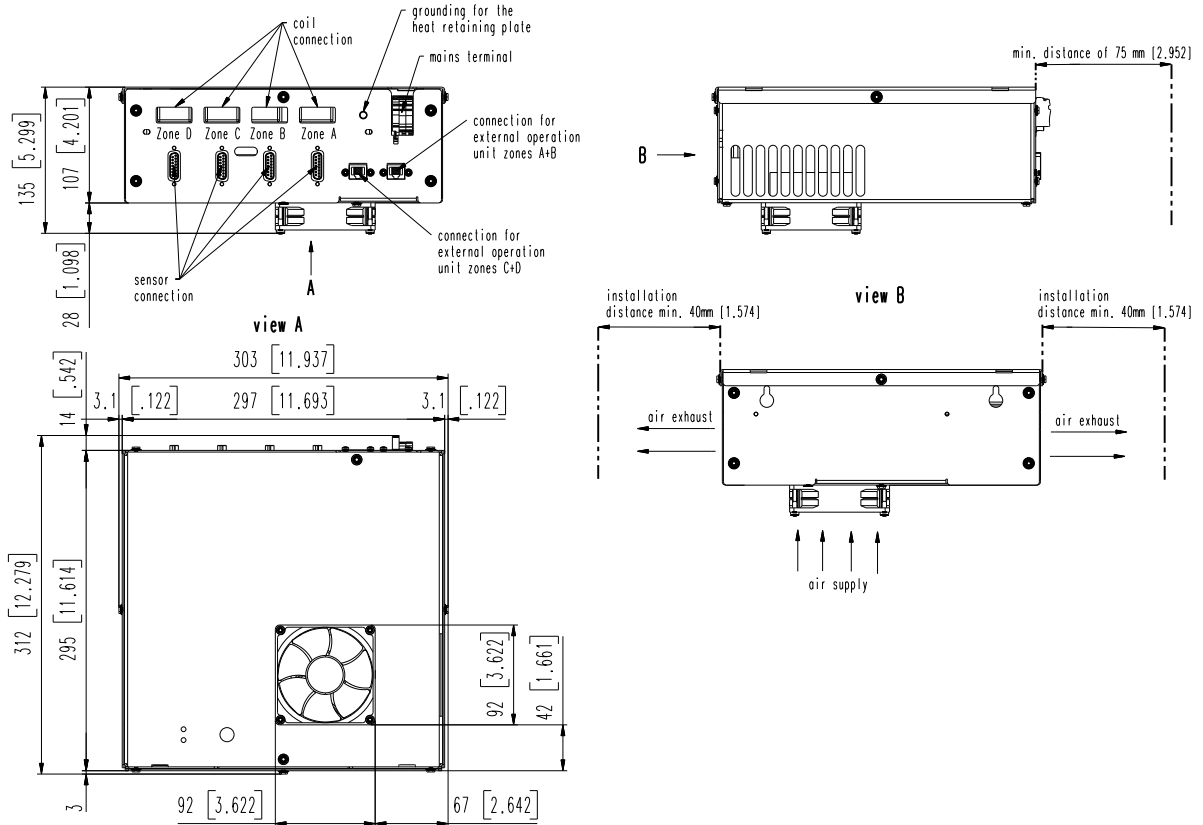
Technical Data:

Generator housing:

11.93"x12.28"x5.31" (303x312x135 mm)

Wattage: 208V, 1Ph, 3200W, 15.4A

 Air flow fan: 3390 ft³/h (96m³/h maximal)

 Cut out for air supply: 9.30 sq. in (6000mm², at least)

Dimensions heat retaining plate:

20.47"x12.60"x2.95" (520x320x75 mm)

Least cut out:

20.79"x12.91"x3.94" (528x328x100 mm)

Qty. of heat retaining plates: 1 - 4

Power per plate: 800W

Ceran glass:

20.47"x12.60"x0.16" (520x320x4 mm)

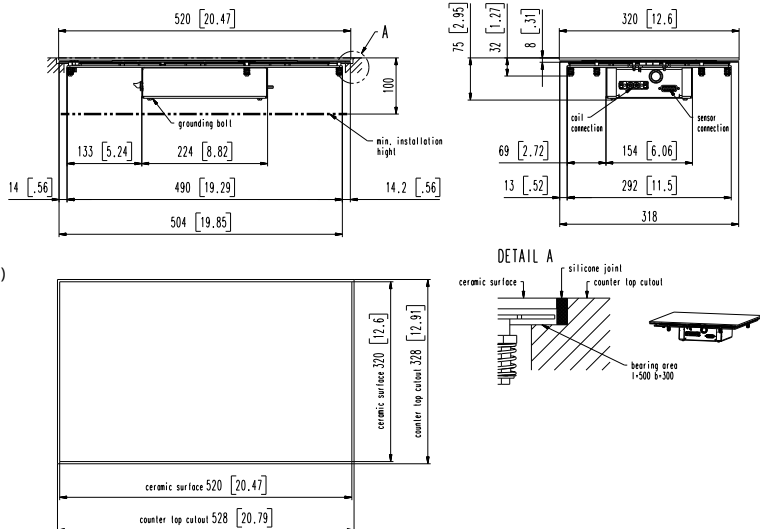

Welbilt reserves the right to make changes to the design or specifications without prior notice.