



GOLD MEDAL® PRODUCTS CO.

Fudge Cooker/Mixer

Model No. 2183-00-200 and 2183-00-210

Specifications

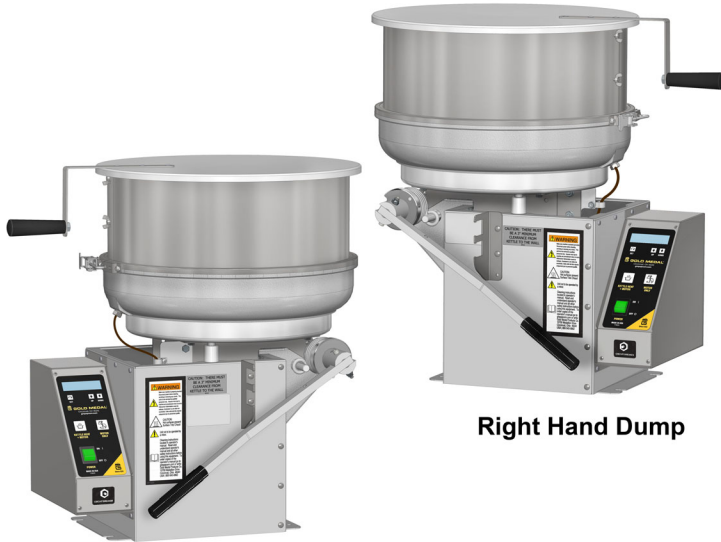

Left Hand Dump

Right Hand Dump

3" Min. Clearance
between Kettle
and Wall.

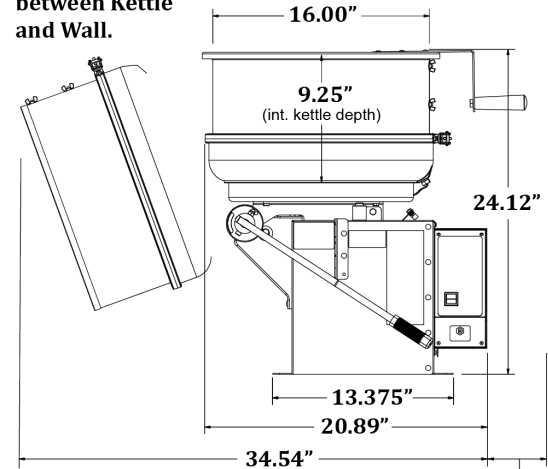

6" Recommended Min. Clearance
between Wall and Cntl Box for Service.

General RH Unit shown above for dim. reference.

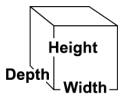

Overall Dimensions:

Width: 20.89" (53 cm)
Depth: 17.6" (44.7 cm)
Height: 24.12" (61.3 cm)

Reference drawing shown for additional dimensions and clearances required.

Note: Optional kit w/drum conversion adds 4.75" to height.

Electrical - Domestic

120/208 OR 120/240V
3408 WATTS 60 Hz
(NEMA L14-20P) Plug

Unit designed to operate on single phase, 20 AMP, 4 wire supply (2 Hot, 1 Neutral, 1 Ground). Wall receptacle is supplied with unit.

Features:

- **Model 2183 (200)** - Right Hand Dump
Model 2183 (210) - Left Hand Dump
- Uses 7 lbs. of dry fudge mix per batch; yields approx. 8 lbs. of fudge
- Membrane Keypad Control with 2-line digital display
- Cast Aluminum Kettle with Stainless Steel Drum

Optional Conversion Kits (kits sold separately):

Corn Treat: 2175KIT (Drum/Paddles)

Frosted Nuts: 2181PAD (Paddle)

Reference Spec Sheet for Kits for further details.

Plug Type:



NEMA L14-20P

Agency Approvals:



Gold Medal Products Co.

10700 Medallion Drive, Cincinnati, OH 45241

Ph: (513) 769-7676, (800) 543-0862; Fax: (513) 769-8500

gmpopcorn.com info@gmpopcorn.com