



**ATLAS METAL**

1135 N.W. 159th DRIVE, MIAMI, FLORIDA 33169

TEL 305.625.2451

TOLL FREE 800.762.7565

FAX 305.623.0475

WWW.ATLASFOODSERV.COM

SALES@ATLASFOODSERV.COM

Project: \_\_\_\_\_

Item No.: \_\_\_\_\_

Quantity: \_\_\_\_\_

**SLIM-LINE DROP-IN SERVING EQUIPMENT**



WIHL-2

**SLIM-LINE  
HOT PAN**

**Electrically Heated  
Individual Controls**

**WIHL-2**

**WIHL-3**

**WIHL-4**

**SPECIFICATIONS**

**TOP:** Constructed of 18 gauge, type 304 stainless steel, die stamped with a raised perimeter bead. There shall be a solid vinyl gasket under the perimeter bead. There shall be a solid vinyl gasket under the beaded edge to form a seal to the counter top, thus preventing seepage or marring of the counter top.

**HOT FOOD WELLS:** Individual hot food wells shall be 18 gauge, type 304 stainless steel, one piece construction, all welded, ground and polished to a uniform finish. All corners are coved with a minimum 1/4" radius. Each well is provided with an 850 watt heating element.

**INSULATION:** The pan is fully insulated with high density fiberglass insulation, 1" thick on all sides, 2" thick on the bottom, and enclosed by a 22 gauge galvanized steel outer case.

**ELECTRICAL:** The unit is provided with an individual thermostat control and pilot light for each well. All heating elements and controls are pre-wired, and a 6' long, 3-wire cord and plug is provided, extending from the control box located under the unit, on operator's left. Bottom of outer case can be removed for access to electrical components.

*Specifications subject to change without notice.*

**STANDARD FEATURES**

- Slim line configuration - it can install in counters only 16" wide
- Fully insulated to retain heat - protects fixtures and saves energy
- Individual thermostat controls - the operator can control the temperature of each well separately
- Factory applied gasket - makes installation a snap and seals units to the counter top, thus eliminating seepage
- Accommodates standard 12" X 20" pans, or fractional size pans with the use of optional adapter bars.
- Wet or Dry Operation
- 1-Year Parts & Labor Warranty
- UL Listed, ETL Listed

**ACCESSORIES**

- Stainless steel adapter bars (pg DI-51-52)
- Stainless steel adapter plates (pg DI-51-52)
- **CPL** - Cover Plate with handles, S/S
- **D** - Individual Drain and Valve for each well (3/4" dia. drain)
- **DM** - Individual Drain for each well with manifold to single valve
- **DMV** - Individual Drain with valve for each well with manifold to single valve
- **DME** - Individual drain for each well with manifold to single valve w/ rear extension
- **RDVE** - Rear Extension for **D**, **DM**, **DMV** & **DME** (1) required
- **RT** - Remote Thermostats for counter installation, 36" long
- **RTL** - Remote Thermostats for counter installation, 72" long
- **MS** - Master on/off switch
- **AF** - Automatic water fill (NOTE: **DM** required for water fill)

\*Please see Operation & Installation Manual for ALL operation and maintenance details.



CONFORMS TO  
NSF/ANSI STD 4  
NSF/ANSI STD 2

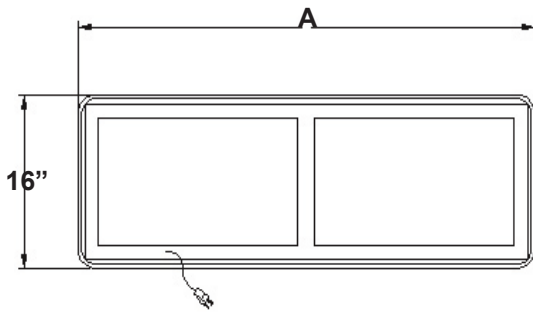

PLAN VIEW

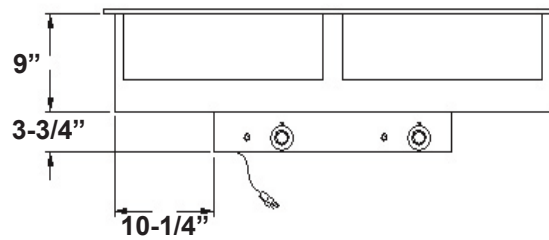

ELEVATION

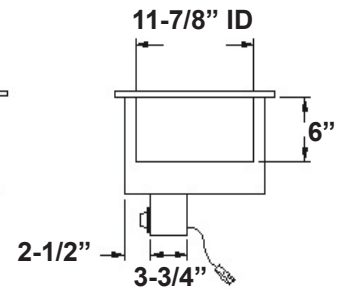

END VIEW

**Electrical Characteristics**

MODEL	WATTAGE	VOLTAGE/KW/AMPS	NEMA # PLUG
WIHL-2	850WATT	120V - 1.7KW - 14.2	5-20P
		208V - 1.7KW - 8.2	6-15P
		240V - 1.7 KW - 7.1	6-15P
	1000WATT	120V - 2.0KW - 16.7	5-30P
		208V - 2.0KW - 9.6	6-15P
		240V - 2.0KW - 8.3	6-15P
WIHL-3	850WATT	120V - 2.55KW - 21.3	5-30P
		208V - 2.55KW - 12.3	L6-20P
		240V - 2.55KW - 10.6	6-15P
	1000WATT	120V - 3.0KW - 25.0	5-50P
		208V - 3.0KW - 14.4	L6-20P
		240V - 3.0KW - 12.5	L6-20P
WIHL-4	850WATT	208V - 3.4KW - 16.4	L6-30P
		240V - 3.4KW - 14.2	L6-20P
	1000WATT	208V - 4.0KW - 19.2	L6-30P
		240V - 4.0KW - 16.7	L6-30P

MODEL	"A"	COUNTER CUT-OUT (REQUIRED) W X L	CONTROL PANEL CUT-OUT (IF REQUIRED)	SHIP WT. (LBS.)
WIHL-2	46" (116.8cm)	14-1/4" X 44-1/4" (36.8 X 113.6cm)	4-1/2" X 12-1/4" (11.4 X 31.1cm)	118 (53.5kg)
WIHL-3	67-3/4" (172cm)	14-1/4" X 66" (36.8 X 167.6cm)	4-1/2" X 26" (11.4 X 66cm)	176 (79.8kg)
WIHL-4	89-1/2" (227.3cm)	14-1/4" X 87-3/4" (36.8 X 222.8cm)	4-1/2" 39-3/4" (11.4 X 100.9cm)	210 (95.2kg)

Note: Numeral following the model letters denotes the 12X20 pan capacity