



24" ADA-HEIGHT COMPLIANT SERIES
Single Door



JOB	
AREA	
ITEM NO.	
MODEL NO.	



HB24RS4
Refrigerator



HB24BS4
Beverage Center



HB24FS4
Freezer Drawers



HB24WS4
Wine Reserve

MODEL NO.	
HB24RS4	Refrigerator
HB24FS4	Freezer
HB24BS4	Beverage Center
HB24WS4	Wine Reserve

Note: NSF/ANSI Standard 7 Listed for the storage and display of bottled or canned products only.

KEY PRODUCT FEATURES AND BENEFITS

- ADA-height compliant controls and height designed to fit under ADA-height compliant counter tops
- All stainless steel interior ensures consistent cabinet temperature and hygienic easy to clean environment that will not absorb odors over time
- Full extension, smooth glide shelving gives easy access to product and faster, more ergonomic product loading
- Ultra-quiet and energy efficient smart compressor – compressor ramps up as additional cooling is needed maximizing energy savings while decreasing pull down time
- NSF rated digital controller allows for precision temperature setting and features an audible door alarm, alerting the operator if an intrusion will not allow the door to close
- Open shelf design allows cold air to surround product reducing temperature variation in the cabinet and extending product life
- 525 BTU/hr fast pull down of product to serving temperature

Quick Features:

- All stainless steel wine shelves ensures zero off gassing or odor absorption
- Accessory wood front available to match custom overlays
- 2" foamed-in-place eco-friendly insulation provides energy savings with zero ozone depletion
- Smart defrost cycle runs only when needed, increasing energy efficiency over standard systems
- Selectable white or blue LEDs provide crisp line of sight to product
- Solid and uv-coated glass door options available in both stainless steel or black vinyl finish
 - Black vinyl door panels can easily be removed to allow a custom wood overlay to be applied
 - Custom door panels are customer supplied – see perlick.com for door overlay templates
- Multiple handle, legs, and caster options available
- Field reversible door allows for easy replacement or re-purposing
- Door lock optional
- NSF 7 rated for canned and bottle beverage storage
- No plumbing required
- 1 Year Warranty, 5 Year Compressor Warranty



24" ADA-HEIGHT COMPLIANT SERIES
Single Door

MODEL NUMBERS - HB24RS4, HB24FS4, HB24BS4, HB24WS4

MODEL NUMBERS		HB24RS4	HB24FS4	HB24BS4	HB24WS4
MODEL DESCRIPTION		Refrigerator	Freezer	Beverage Center	Wine Reserve
OVERALL DIMENSIONS	Width - in. (mm)	23-7/8 (606)	23-7/8 (606)	23-7/8 (606)	23-7/8 (606)
	Depth - in. (mm)	24 (610)	24 (610)	24 (610)	24 (610)
	Height - in. (mm)	32 (813)	32 (813)	32 (813)	32 (813)
STANDARD OPENING DIMENSIONS	Width - in. (mm)	24 (610)	24 (610)	24 (610)	24 (610)
	Depth - in. (mm)	24 (610)	24 (610)	24 (610)	24 (610)
	Height - in. (mm)	32-1/8 (816)	32-1/8 (816)	32-1/8 (816)	32-1/8 (816)
INTERNAL VOLUME Net. Cu. Ft. (L)		4.8 (136)	4.8 (136)	4.8 (136)	4.8 (136)
SHIPPING WEIGHT Lbs. (kg.)		195 (88)	195 (88)	195 (88)	195 (88)
ELECTRICAL SPECIFICATIONS	Electrical Supply	115 VAC/60 Hz/1 Ph	115 VAC/60 Hz/1 Ph	115 VAC/60 Hz/1 Ph	115 VAC/60 Hz/1 Ph
	Running Load Amps	1.9	2.4	1.9	1.9
	Electrical Connection	Cord connected	Cord connected	Cord connected	Cord connected
	Cord Plug Type	NEMA 5-15P	NEMA 5-15P	NEMA 5-15P	NEMA 5-15P
	Cord Length	6'	6'	6'	6'
	Defrost Initiation	Automatic	Automatic	Automatic	Automatic
	Defrost Type	Off cycle	Hot Gas	Off cycle	Off cycle
	Thermostat	Digital	Digital	Digital	Digital
REFRIGERATION SPECIFICATIONS	Lighting Type	LED	LED	LED	LED
	Refrigerant	R600a (62g)	R600a (60g)	R600a (62g)	R600a (62g)
	Expansion Device	Capillary Tube	Capillary Tube	Capillary Tube	Capillary Tube
	Temperature Settings F°(C°)	34° (1.1°) - 42° (5.6°) Factory Set Point 36° (2.2°)	-10° (-23.3°) - 10° (-12.2°) Factory Set Point 0° (-17.8°)	34° (1.1°) - 48° (8.9°) Factory Set Point 42° (5.6°)	40° (4.4°) - 68° (20°) Factory Set Point 55° (12.8°)
	Heat Rejection (at 75°F)	450 BTU/hr	700 BTU/hr	450 BTU/hr	450 BTU/hr
	Pull Down Capacity	525 BTU/hr	525 BTU/hr	525 BTU/hr	525 BTU/hr
FRONT VENTED		Yes	Yes	Yes	Yes
PLUMBING		None Required	None Required	None Required	None Required

AVAILABLE DOOR/DRAWER STYLES	HB24RS4	HB24FS4	HB24BS4	HB24WS4
Solid Black Vinyl/Field Laminate (Lock Optional)	X	X	X	X
Solid Stainless Steel (Lock Optional)	X	X	X	X
Glass w/Black Vinyl/Field Laminate (Lock Optional)	X		X	X
Glass w/Stainless Steel (Lock Optional)	X		X	X
Drawers Solid Black Vinyl/Field Laminate (Lock INCLUDED)	X	X		
Drawers Stainless Steel (Lock INCLUDED)	X	X		

*Doors/Drawers can be finished with wood overlay panels (by others). Contact Perlick for drawing templates.

California Prop 65 Notice:

WARNING: The materials used in this product may contain chemicals known to the State of California to cause cancer and birth defects or other reproductive harm, For more information go to www.P65Warnings.ca.gov.

Form No. Z2364
Rev. 04.12.22

Perlick® **24" ADA-HEIGHT COMPLIANT SERIES**
Single Door

CABINET CONSTRUCTION	HB24RS4	HB24FS4	HB24BS4	HB24WS4
Cabinet Construction - Exterior	Top & sides are Stainless Steel. Back is Galvanized. Doors - see door chart on front.			
Cabinet Construction - Interior	Stainless Steel			
Cabinet Insulation	Polyurethane-Ecomate. Wall Thickness 2" (foamed-in-place)			
SHELVING (Excludes Drawers)	HB24RS4	HB24FS4	HB24BS4	HB24WS4
Black Vinyl-Coated Full Extension Shelves	2	2	1	-
Black Vinyl-Coated Full Extension Wine Shelves f/(8) 750ml Bottles	-	-	2	4
DOOR HANDLES	HB24RS4	HB24FS4	HB24BS4	HB24WS4
Door Handles	24" Full Length - Stainless Steel, Classic 6" Black Vinyl Handle w/Chrome Ends, 12" Stainless Steel, Tab Handles - Top Mounted			

NOTE: This equipment is intended for the storage and display of non-potentially hazardous bottled or canned products only!

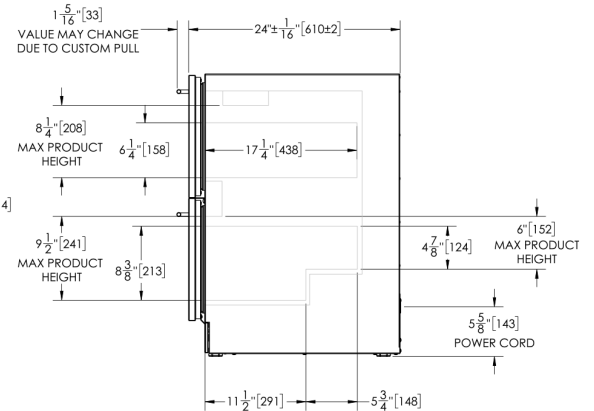
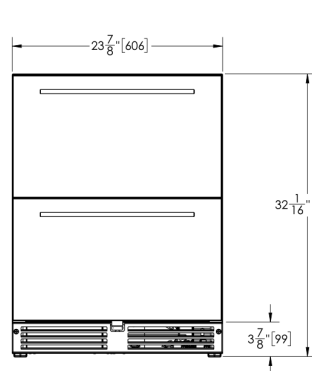
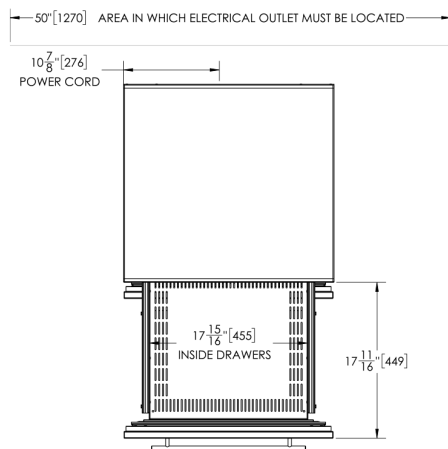
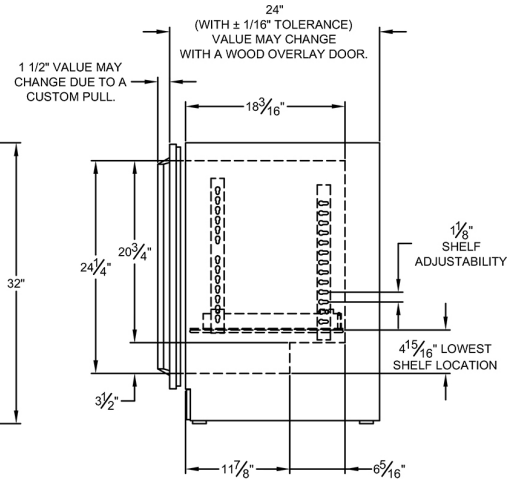
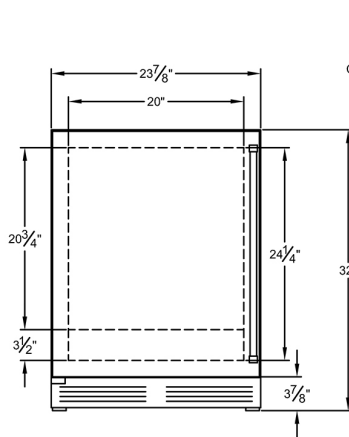
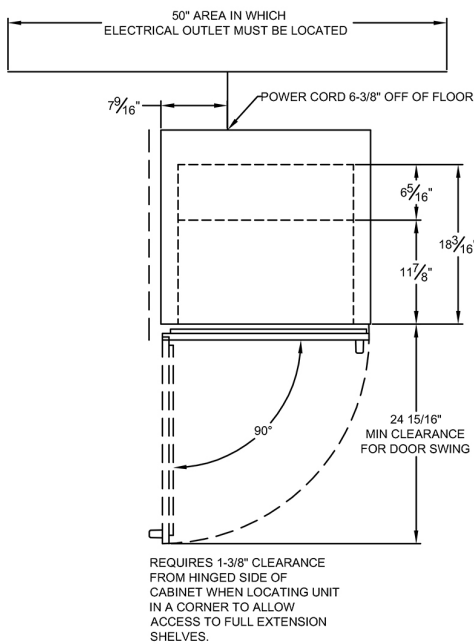

California Prop 65 Notice:

WARNING: The materials used in this product may contain chemicals known to the State of California to cause cancer and birth defects or other reproductive harm, For more information go to www.P65Warnings.ca.gov.

Form No. Z2364
Rev. 04.12.22