

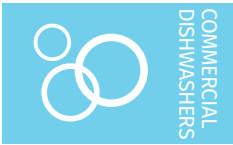

Project \_\_\_\_\_  
 AIA # \_\_\_\_\_ SIS # \_\_\_\_\_  
 Item # \_\_\_\_\_ Quantity \_\_\_\_\_ C.S.I. Section 114000

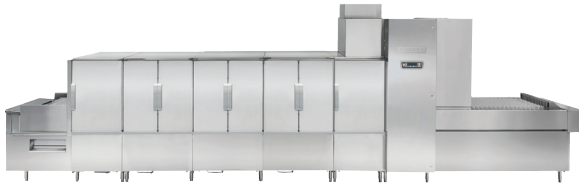

## FT1000Se BASE ELECTRIC Flight-Type Dishwashing Machine



Advansys model shown



Complies with EPA Reduction of Lead in Drinking Water Act 2014

Meets requirements of ASSE Standard No. 1004

### SPECIFIER STATEMENT

The specified machine shall be a Hobart flight type dish machine, 58 gallons of final rinse consumption per hour, with dual rinse, hinged & insulated doors, 30" wide conveyor belt, capless wash arms & microprocessor controls.

### STANDARD FEATURES

- + Pumped rinse system (pressure gauge not required)
- + Water usage 58 gph
- + Digital controls with machine diagnostics
- + Low temperature alert
- + Hinged insulated cabinet-style doors
- + 31" access on prewash, power wash chamber; 20" access on dual rinse and ASR chambers
- + Start and stop switches at both ends
- + Doors open indicator
- + Drains open indicator
- + Door interlocks
- + 3½ H.P. prewash and power wash pump motors, all TEFC
- + Capless wash arms
- + Easy to remove stainless steel scrap pans and baskets
- + 30" wide conveyor belt
- + Dual rinse
- + Front and rear panels
- + Variable speed conveyor
- + Electric booster heater
- + Configurable drain to load or unload

### OPTIONS & ACCESSORIES (Available at extra cost)

- Multiple conveyor options
- Factory mounted circuit breakers
- 6" higher than standard chamber
- Flanged feet (field installed)
- Water hammer arrestor/PRV (field installed)
- Drain water tempering kit (field installed)
- WS-80 water softener (field installed)
- Insulated split, vertical slide-up doors
- Correctional packages available – contact Hobart for more information
- Casino packages

FT SERIES – FT1000Se BASE ELECTRIC

Approved by \_\_\_\_\_ Date \_\_\_\_\_ Approved by \_\_\_\_\_ Date \_\_\_\_\_



# FT1000Se BASE ELECTRIC

## Flight-Type Dishwashing Machine

(Left to Right)

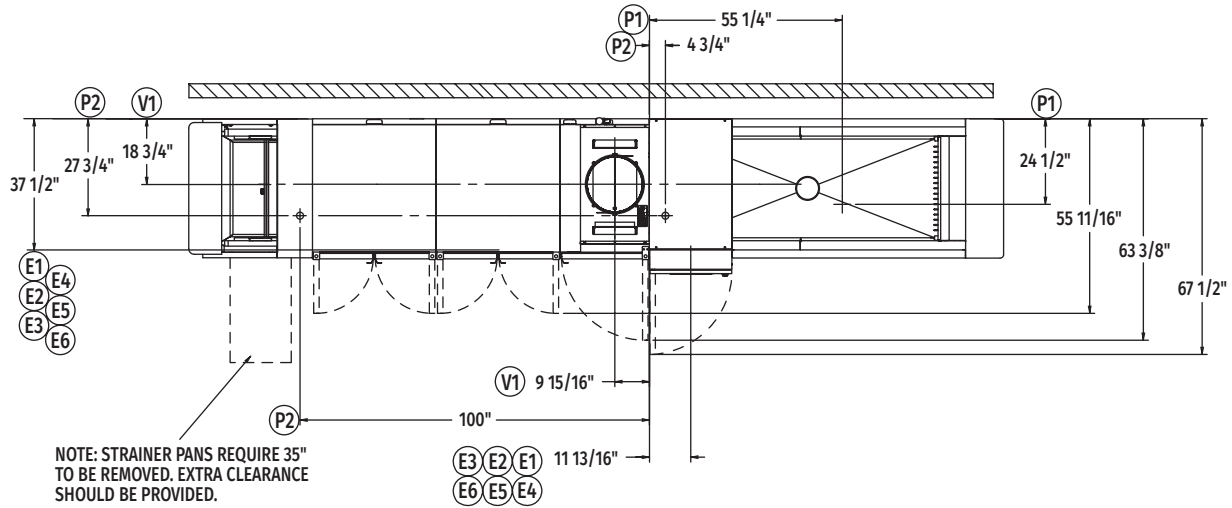

Top View Left to Right

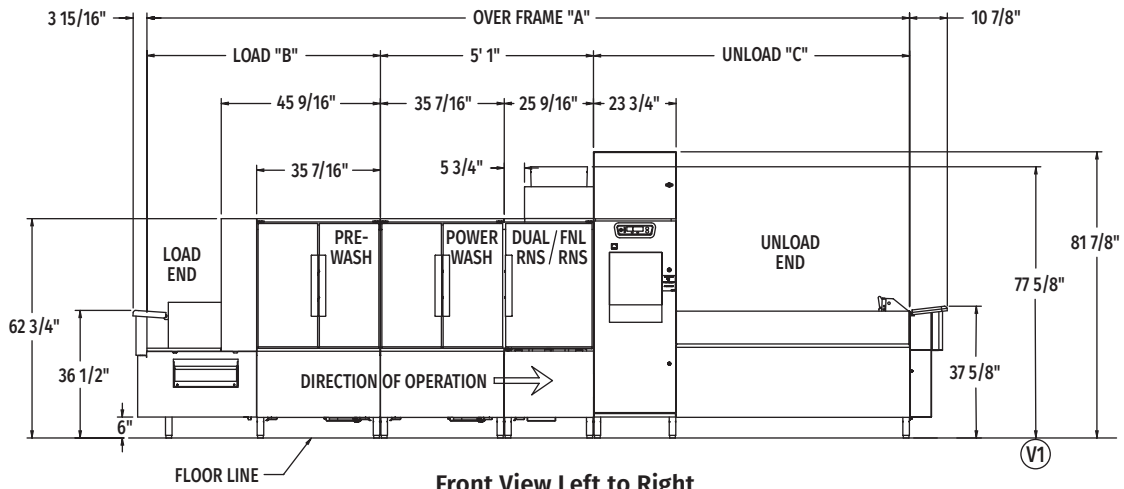

Front View Left to Right

Note: Control box electrical connections – see page 5.

MODEL NO.	"A"	"B"	"C"
FT1016Se (5.5'-5'-5.5')	16' 2-15/16"	5' 6-15/16"	5' 7"
FT1017Se (6.5'-5'-5.5')	17' 2-11/16"	6' 6-11/16"	5' 7"
FT1018Se (7.5'-5'-5.5')	18' 2-17/32"	7' 6-17/32"	5' 7"
FT1018Se (5.5'-5'-7.5')	18' 2-7/16"	5' 6-15/16"	7' 6-1/2"
FT1019Se (6.5'-5'-7.5')	19' 2-3/16"	6' 6-11/16"	7' 6-1/2"
FT1020Se (7.5'-5'-7.5')	20' 2-1/32"	7' 6-17/32"	7' 6-1/2"
FT1020Se (5.5'-5'-9')	19' 10-3/16"	5' 6-15/16"	9' 2-1/4"
FT1021Se (6.5'-5'-9')	20' 9-15/16"	6' 6-11/16"	9' 2-1/4"
FT1022Se (7.5'-5'-9')	21' 9-25/32"	7' 6-17/32"	9' 2-1/4"
FT1022Se (5.5'-5'-11')	21' 9-13/16"	5' 6-15/16"	11' 1-7/8"
FT1023Se (6.5'-5'-11')	22' 9-9/16"	6' 6-11/16"	11' 1-7/8"
FT1024Se (7.5'-5'-11')	23' 9-13/32"	7' 6-17/32"	11' 1-7/8"
FT1025Se (5.5'-5'-15')	25' 5-1/8"	5' 6-15/16"	14' 9-3/16"
FT1026Se (6.5'-5'-15')	26' 4-7/8"	6' 6-11/16"	14' 9-3/16"
FT1027Se (7.5'-5'-15')	27' 4-23/32"	7' 6-17/32"	14' 9-3/16"
FT1027Se (5.5'-5'-17')	27' 4-11/16"	5' 6-15/16"	16' 8-3/4"
FT1028Se (6.5'-5'-17')	28' 4-7/16"	6' 6-11/16"	16' 8-3/4"
FT1029Se (7.5'-5'-17')	29' 4-9/32"	7' 6-17/32"	16' 8-3/4"

Note: Overall length of machine is Dimension "A" + 14-13/16"

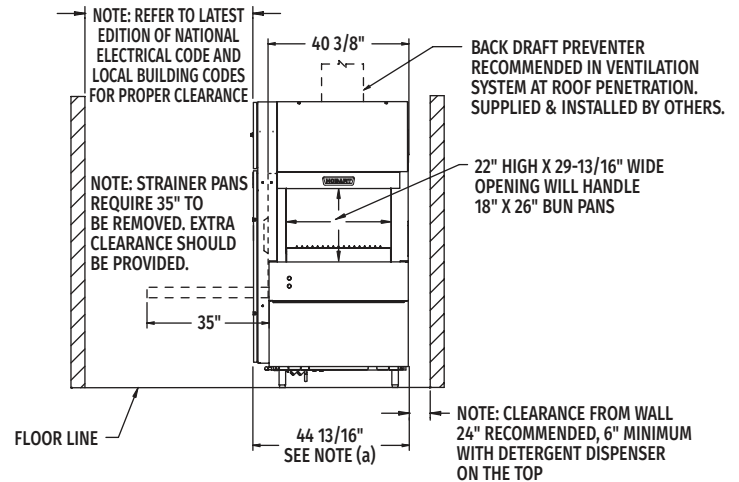

Back/Unload End

MODEL: FT1000Se BASE ELECTRIC L-R OPERATION 00-562369 REV B



# FT1000Se BASE ELECTRIC

## Flight-Type Dishwashing Machine

(Right to Left)

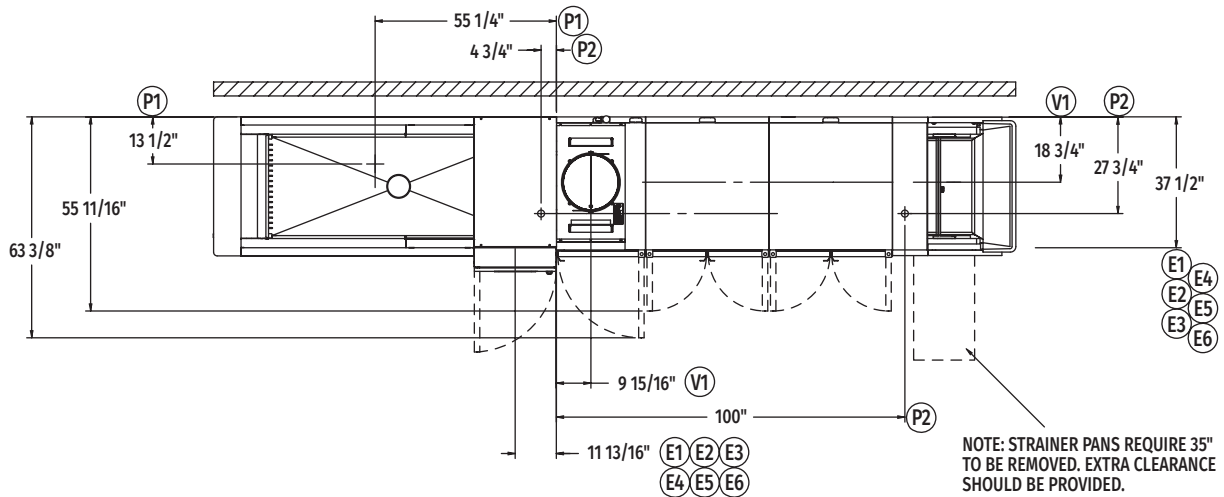

Top View Right to Left

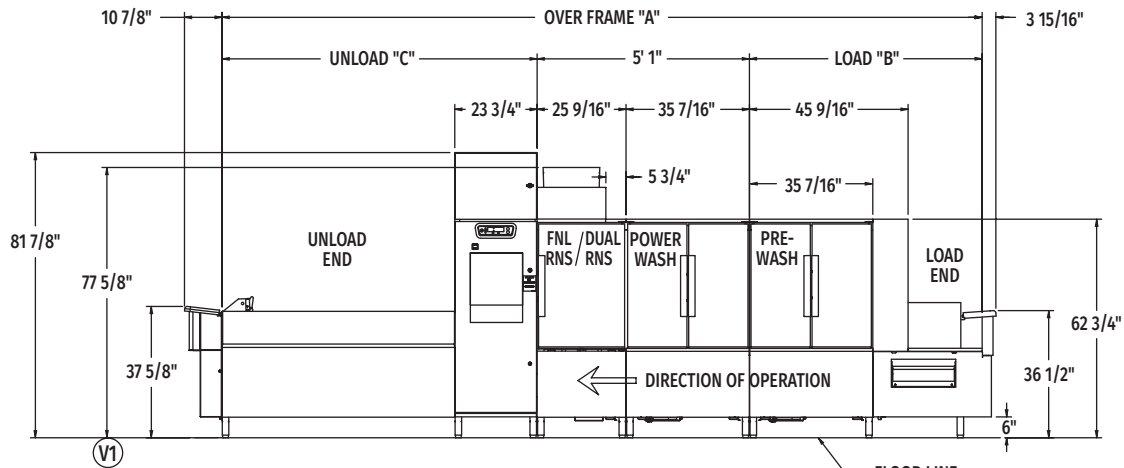

Front View Right to Left

Note: Control box electrical connections – see page 5.

MODEL NO.	"A"	"B"	"C"
FT1016Se (5.5'-5'-5.5')	16' 2-15/16"	5' 6-15/16"	5' 7"
FT1017Se (6.5'-5'-5.5')	17' 2-11/16"	6' 6-11/16"	5' 7"
FT1018Se (7.5'-5'-5.5')	18' 2-17/32"	7' 6-17/32"	5' 7"
FT1018Se (5.5'-5'-7.5')	18' 2-7/16"	5' 6-15/16"	7' 6-1/2"
FT1019Se (6.5'-5'-7.5')	19' 2-3/16"	6' 6-11/16"	7' 6-1/2"
FT1020Se (7.5'-5'-7.5')	20' 2-1/32"	7' 6-17/32"	7' 6-1/2"
FT1020Se (5.5'-5'-9')	19' 10-3/16"	5' 6-15/16"	9' 2-1/4"
FT1021Se (6.5'-5'-9')	20' 9-15/16"	6' 6-11/16"	9' 2-1/4"
FT1022Se (7.5'-5'-9')	21' 9-25/32"	7' 6-17/32"	9' 2-1/4"
FT1022Se (5.5'-5'-11')	21' 9-13/16"	5' 6-15/16"	11' 1-7/8"
FT1023Se (6.5'-5'-11')	22' 9-9/16"	6' 6-11/16"	11' 1-7/8"
FT1024Se (7.5'-5'-11')	23' 9-13/32"	7' 6-17/32"	11' 1-7/8"
FT1025Se (5.5'-5'-15')	25' 5-1/8"	5' 6-15/16"	14' 9-3/16"
FT1026Se (6.5'-5'-15')	26' 4-7/8"	6' 6-11/16"	14' 9-3/16"
FT1027Se (7.5'-5'-15')	27' 4-23/32"	7' 6-17/32"	14' 9-3/16"
FT1027Se (5.5'-5'-17')	27' 4-11/16"	5' 6-15/16"	16' 8-3/4"
FT1028Se (6.5'-5'-17')	28' 4-7/16"	6' 6-11/16"	16' 8-3/4"
FT1029Se (7.5'-5'-17')	29' 4-9/32"	7' 6-17/32"	16' 8-3/4"

Note: Overall length of machine is Dimension "A" + 14'-13/16"

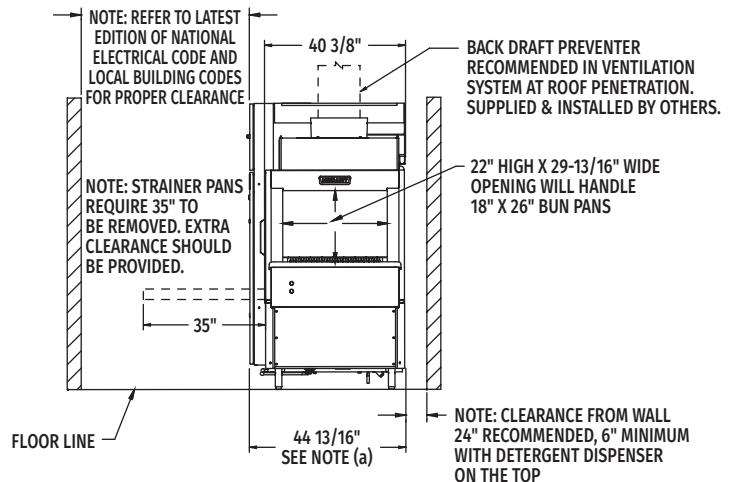

Back/Unload End

MODEL:  
FT1000Se BASE  
ELECTRIC  
R-L OPERATION  
00-562368  
REV B



# FT1000Se BASE ELECTRIC

## Flight-Type Dishwashing Machine

(Left to Right)

### LEGEND

Electrical Connections	
E1	Electric connection for 1TB with or without circuit breakers. 79-1/8" AFF.
E2	Electric connection for 2TB without circuit breakers. 79-1/8" AFF.
E3	Electric connection for 3TB without circuit breakers. 79-1/8" AFF.
E4	Electric connection for 4TB without circuit breakers. 79-1/8" AFF.
E5	Electric connection for 5TB without circuit breakers. 79-1/8" AFF.
E6	Electric connection for 2TB with circuit breakers. 79-1/8" AFF.
Plumbing Connections	
P1	Common hot water connection (automatic fill) 110° F water minimum, 1" FPT, 5-1/2" AFF.
P2	Drain connection: Default location is drain to unload. May be drained to either end of unit. 2" FPT, 7" AFF.
Ventilation Connections	
V1	Customers' vent connection. Must fit inside 16" diameter vent stack providing 750 CFM exhaust at machine connection @ .75" water column (standard air conditions). Back draft damper is RECOMMENDED ON ALL BAS models. 77-5/8" AFF.

### SERVICE CONNECTIONS WITH CIRCUIT BREAKERS (2 CONNECTIONS)

E1	Motors, Controls & Booster Heat (1TB) (1) Service Connection as Shown Below			
Voltage	Rated Amps	Minimum Supply Circuit Ampacity	Maximum Protective Device	
208/60/3	70.7	90	90	
240/60/3	65.2	90	90	
480/60/3	36.1	50	50	
600/60/3	28.7	40	40	
E6	Wash, Dual Rinse Heat (2TB) (1) Service Connection as Shown Below			
Voltage	Rated Amps	Minimum Supply Circuit Ampacity	Maximum Protective Device	
208/60/3	125.7	175	175	
240/60/3	109.0	150	150	
480/60/3	54.5	70	70	
600/60/3	43.6	60	60	

**WARNING:** Plumbing and electrical connections should be made by qualified personnel who will observe all the applicable plumbing, sanitary, safety codes and National Electrical Code.

#### General Notes:

(a) The control box is attached to the center section and is rotated 90 degrees for shipping.

AFF = Above Finished Floor

All dimensions taken from the floor line may increase 3-1/4" with leg adjustment.

For convenience when cleaning, customer should install water tap near machine with 30 ft. of heavy duty hose with squeeze valve.

This drawing is supplied as a reference for connection information only. It will not be utilized for manufacturing of unit.

#### Electrical Notes:

Service wire temperature rating: 90°C minimum.

Detergent and rinse aid feeder service connections standard on all FT1000e models at machine line voltage.

Dishmachine not provided with internal GFCI protection.

#### Plumbing Notes:

Recommended building flowing hot water pressure to the dishwasher is 30-35 PSI.

Water hammer arrestor (meeting ASSE-1010 standard or equivalent) to be supplied (by others) in hot supply line at service connection.

#### Ventilation Notes:

Room ventilation is required to handle machine's latent & sensible heat.

Vent fan control standard on all FT1000e models.

#### Water Quality Required:

Total water hardness < 3 grains per gallon.

Total suspended solids (TSS) < 10 microns.

### SERVICE CONNECTION WITH CIRCUIT BREAKERS (SINGLE POINT ELECTRICAL CONNECTION)

E1	Motors, Controls, Dual Rinse (1TB), Wash & Booster Heat			
Voltage	Rated Amps	Minimum Supply Circuit Ampacity	Maximum Protective Device	
480/60/3	90.6	125	125	
600/60/3	72.3	100	100	



# FT1000Se BASE ELECTRIC

## Flight-Type Dishwashing Machine

(Right to Left)

### SERVICE CONNECTIONS WITHOUT CIRCUIT BREAKERS (5 CONNECTIONS)

E1 Motors & Controls (1TB) (1) Service Connection as Shown Below			
Voltage	Rated Amps	Minimum Supply Circuit Ampacity	Maximum Protective Device
208/60/3	29.1	40	40
240/60/3	29.1	40	40
480/60/3	18.1	25	25
600/60/3	14.3	20	20
E2 Electric Tank Heat, Wash (2TB) (1) 17.3 kW Connection as Shown Below			
Voltage	Rated Amps	Minimum Supply Circuit Ampacity	Maximum Protective Device
208/60/3	48.0	70	70
240/60/3	41.6	60	60
480/60/3	20.8	30	30
600/60/3	16.6	25	25
E3 Electric Tank Heat, Wash (3TB) (1) 17.3 kW Connection as Shown Below			
Voltage	Rated Amps	Minimum Supply Circuit Ampacity	Maximum Protective Device
208/60/3	48.0	70	70
240/60/3	41.6	60	60
480/60/3	20.8	30	30
600/60/3	16.6	25	25
E4 Dual Rinse (4TB) (1) 10.7 kW Connection as Shown Below			
Voltage	Rated Amps	Minimum Supply Circuit Ampacity	Maximum Protective Device
208/60/3	29.7	40	40
240/60/3	25.7	35	35
480/60/3	12.9	20	20
600/60/3	10.3	15	15
E5 Electric Booster (5TB) (1) 15 kW Connection as Shown Below			
Voltage	Rated Amps	Minimum Supply Circuit Ampacity	Maximum Protective Device
208/60/3	41.6	60	60
240/60/3	36.1	50	50
480/60/3	18.0	25	25
600/60/3	14.4	20	20

Heat Gain to Space (BTU/Hr.)	
Latent	Sensible
65,400	28,000

### SPECIFICATIONS

#### Capacities

Conveyor Speed (feet per minute)	4.0 - 6.3
Dishes per Hour	10,611
Pre-Wash Tank (U.S. gallons)	40
Wash Tank (U.S. gallons)	40
Dual Rinse Tank (U.S. gallons)	7.2

#### Motor Horsepower

Pre-Wash Tank	3½
Wash Tank	3½
Dual Rinse Tank	¾
Final Rinse	½
Conveyor	¾

#### Water Consumption

U.S. Gallons per Hour (maximum use)	58
U.S. Gallons per Minute	0.97

#### Heating

Tank Heat, Electric	Total tank heat - 45.3 kW (kW regulated)	(Wash, Dual Rinse)
Electric Booster (kW)	15	

**Shipping Weight (approximate)** . . . Varies by individual model  
(Consult your Hobart representative)

**Crated Dimensions** . . . . . Varies by individual model  
(Consult your Hobart representative)

FT1000 Advansys Water Treatment System	
Model	Description
WS-80	Water Softener
<b>Available through Hobart Service only</b>	
PF-10-EHT	Hi-Temp Filter Housing
SD-510HT	Sediment Filter Cartridge

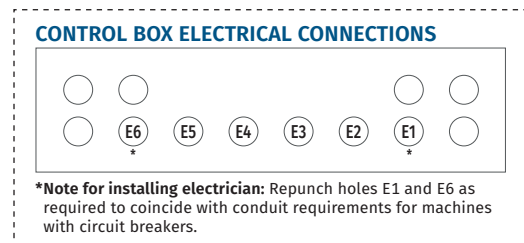

**Detail "A-A"**  
(not to scale)

### CONVEYOR TYPE OPTIONS

All conveyors provided with standard polypropylene material. Optional stainless steel conveyors available by request. Please contact your sales representative for stainless steel conveyor options.

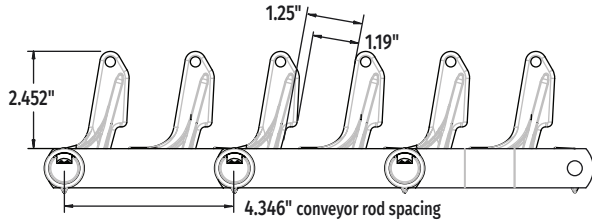

#### STANDARD

Standard Conveyor designed for General Ware including tableware (Plates/Bowls), most serving trays (lip height less than 1 $\frac{1}{2}$ "") as well as prep-ware (Hotel & Sheet Pans).

- Optional cross-rods every 4th row available for additional support of heavier ware (oversized ware/mixing bowls) as well as to promote warewashing drainage at optimal angle (hotel pans).

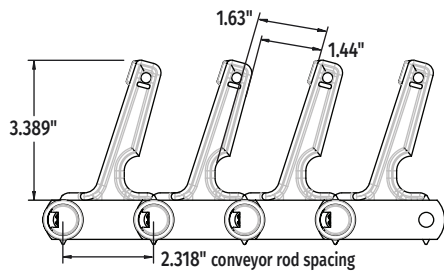

#### TYPE A

Optional Conveyor designed exclusively with our Healthcare segments in mind. In addition to accommodating General Ware, the Type A conveyor has a tighter conveyor rod spacing which provides increased conveyor density for added strength, as well as additional finger height and spacing to support most insulated dome bases and lids.

- Optional cross-rods every 4th row available for additional support of heavier ware (oversized ware/mixing bowls) as well as to promote warewashing drainage at optimal angle (hotel pans).

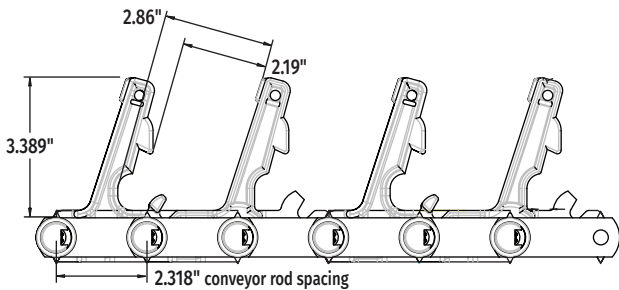

#### POSITION 1

Optional Conveyor designed for customers using insulated compartmentalized trays, as well as thicker insulated dome bases and lids. In addition to accommodating General Ware, the Position 1 conveyor provides even greater spacing between fingers, as well as a pronounced  $\frac{3}{8}$ " "nose" to secure compartmentalized trays in place.

- Optional cross-rods every 4th row available for additional support of heavier ware (oversized ware/mixing bowls) as well as to promote warewashing drainage at optimal angle (hotel pans). Cross-rods can also be used to create stable support for some compartmentalized trays to orient upright through dishmachine.

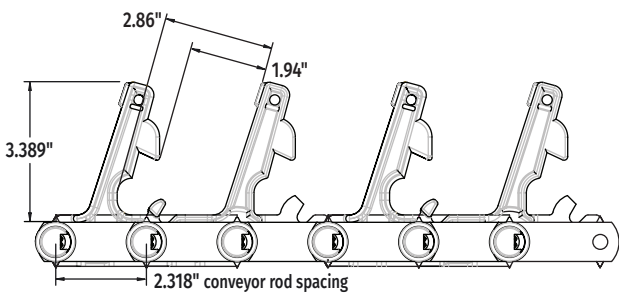

#### POSITION 2

Optional Conveyor designed for customers using insulated compartmentalized trays, as well as thicker insulated dome bases and lids. In addition to accommodating General Ware, the Position 2 conveyor provides additional spacing between fingers, as well as a pronounced  $\frac{5}{8}$ " "nose" to secure compartment trays in place.

- Optional cross-rods every 4th row available for additional support of heavier ware (oversized ware/mixing bowls) as well as to promote warewashing drainage at optimal angle (hotel pans). Cross-rods also create stable support for compartmentalized trays to orient upright through dishmachine.

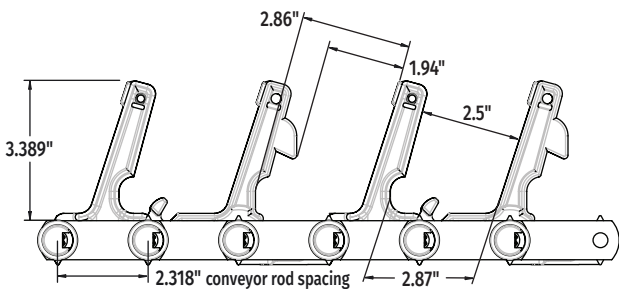

#### TIVOLI

Optional Conveyor designed exclusively with our Correctional segments in mind. In addition to accommodating General Ware, the Tivoli conveyor provides our widest spacing between fingers as well as a  $\frac{3}{8}$ " "nose" to support the largest insulated compartmentalized trays, commonly used in correctional settings. The Tivoli conveyor comes standard with cross-rods every 3rd row for additional support of heavier ware (oversized ware/mixing bowls) as well as to promote warewashing drainage at optimal angle (hotel pans). Cross-rods also create stable support for compartmentalized trays to orient upright through dishmachine.

As continued product improvement is a policy of Hobart, specifications are subject to change without notice.