



Profit from the Eagle Advantage®

Specification Sheet

Short Form Specifications

Eagle Spec-Master® Enclosed Base Worktable, model _____ . Top is 14/304 stainless steel, sides and back are heavy gauge stainless steel. (Open Front, Stainless Steel Sliding Door, or Stainless Steel Hinged Door) models with 1½" rolled edge on front, sides turned down, and 4" backsplash on rear. Constructed with uni-lok® patented gusset system, with the gussets recessed into the hat channels to reduce lateral movement. 1½" O.D. stainless steel tubular legs with adjustable bullet feet.



enclosed worktable with hinged doors

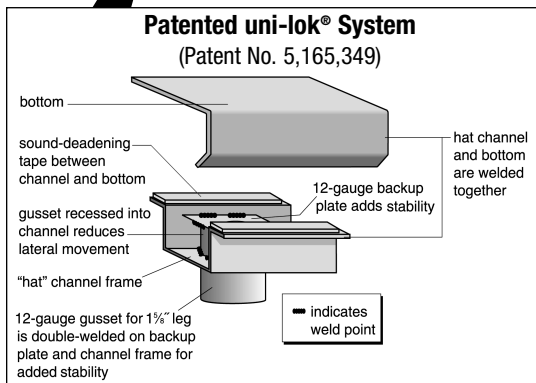

Item No.: _____
 Project No.: _____
 S.I.S. No.: _____

Spec-Master® Enclosed Worktables with Backsplash

MODELS:

- | | | |
|---------------------------------------|---------------------------------------|--|
| <input type="checkbox"/> OB2436SE-BS | <input type="checkbox"/> CB2436SE-BS | <input type="checkbox"/> CBH2436SE-BS |
| <input type="checkbox"/> OB2448SE-BS | <input type="checkbox"/> CB2448SE-BS | <input type="checkbox"/> CBH2448SE-BS |
| <input type="checkbox"/> OB2460SE-BS | <input type="checkbox"/> CB2460SE-BS | <input type="checkbox"/> CBH2460SE-BS |
| <input type="checkbox"/> OB2472SE-BS | <input type="checkbox"/> CB2472SE-BS | <input type="checkbox"/> CBH2472SE-BS |
| <input type="checkbox"/> OB2484SE-BS | <input type="checkbox"/> CB2484SE-BS | <input type="checkbox"/> CBH2484SE-BS |
| <input type="checkbox"/> OB2496SE-BS | <input type="checkbox"/> CB2496SE-BS | <input type="checkbox"/> CBH2496SE-BS |
| <input type="checkbox"/> OB24120SE-BS | <input type="checkbox"/> CB24120SE-BS | <input type="checkbox"/> CBH24120SE-BS |
| <input type="checkbox"/> OB3036SE-BS | <input type="checkbox"/> CB3036SE-BS | <input type="checkbox"/> CBH3036SE-BS |
| <input type="checkbox"/> OB3048SE-BS | <input type="checkbox"/> CB3048SE-BS | <input type="checkbox"/> CBH3048SE-BS |
| <input type="checkbox"/> OB3060SE-BS | <input type="checkbox"/> CB3060SE-BS | <input type="checkbox"/> CBH3060SE-BS |
| <input type="checkbox"/> OB3072SE-BS | <input type="checkbox"/> CB3072SE-BS | <input type="checkbox"/> CBH3072SE-BS |
| <input type="checkbox"/> OB3084SE-BS | <input type="checkbox"/> CB3084SE-BS | <input type="checkbox"/> CBH3084SE-BS |
| <input type="checkbox"/> OB3096SE-BS | <input type="checkbox"/> CB3096SE-BS | <input type="checkbox"/> CBH3096SE-BS |
| <input type="checkbox"/> OB30120SE-BS | <input type="checkbox"/> CB30120SE-BS | <input type="checkbox"/> CBH30120SE-BS |

Features

- All-welded design.
- Available with open front, sliding doors, or hinged doors.
- Doors are 20 gauge type 430 stainless steel.
- Top mechanically polished to satin finish.
- Top is 14 gauge type 304 stainless steel reinforced with a full length "hat" channel support.
- Body is heavy gauge type 430 stainless steel.
- Sound-deadened between top and frame.
- 1½" (42mm)-diameter type 304 stainless legs.
- 1" (25mm) adjustable stainless steel feet.
- 1½" (38mm) sanitary rolled rim on front.
- 4½" (114mm) backsplash on rear.
- Square edge on ends for flush fit.
- Optional fixed center shelf available. To order, add suffix "-CS" to model number. Example: OB2436SE-BS-CS

Options / Accessories

- | | |
|--|--|
| <input type="checkbox"/> Lock (for units with doors) | <input type="checkbox"/> Center shelf |
| <input type="checkbox"/> Casters* | <input type="checkbox"/> Sound deadening |
| <input type="checkbox"/> Overshelf | |

* To order table with 4" (102mm)-diameter casters, add suffix "-CA" (ex: OB3048SE-BS-CA). To order table with 5" (127mm)-diameter casters, add suffix "-CAH" (ex: CB3048SE-BS-CAH).

EAGLE GROUP

100 Industrial Boulevard
 Clayton, DE 19938-8903 USA

Phone: 302-653-3000 • 800-441-8440

Fax: 302-653-2065

www.eaglegrp.com • www.eaglemhc.com

For custom configuration or fabrication needs, contact our SpecFAB® Division.

Phone: 302-653-3000 • Fax: 302-653-2065 • e-mail: quotes@eaglegrp.com

Certifications / Approvals



AutoQuotes



EG10.32 Rev. 08/22

Spec sheets available for viewing, printing or downloading from our online literature library at www.eaglegrp.com

Eagle Foodservice Equipment, Eagle MHC, and SpecFAB® are divisions of Eagle Group. ©2022 by the Eagle Group



Item No.: _____
 Project No.: _____
 S.I.S. No.: _____

Spec-Master® Enclosed Worktables with Open Front

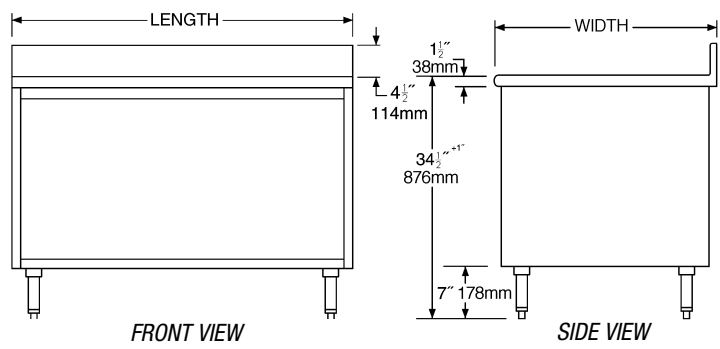

model #	width		length		weight		no. of legs
	in.	mm	in.	mm	lbs.	kg	
OB2436SE-BS	24"	610	36"	914	133	60.3	4
OB2448SE-BS	24"	610	48"	1219	161	73.0	4
OB2460SE-BS	24"	610	60"	1524	202	91.6	4
OB2472SE-BS	24"	610	72"	1829	243	110.2	4
OB2484SE-BS	24"	610	84"	2134	284	128.8	6
OB2496SE-BS	24"	610	96"	2438	326	147.9	6
OB24120SE-BS	24"	610	120"	3048	390	176.9	6
OB3036SE-BS	30"	762	36"	914	137	62.1	4
OB3048SE-BS	30"	762	48"	1219	167	75.8	4
OB3060SE-BS	30"	762	60"	1524	201	91.2	4
OB3072SE-BS	30"	762	72"	1829	251	113.9	4
OB3084SE-BS	30"	762	84"	2134	299	135.6	6
OB3096SE-BS	30"	762	96"	2438	344	156.0	6
OB30120SE-BS	30"	762	120"	3048	438	198.7	6

Spec-Master® Enclosed Worktables with Sliding Doors

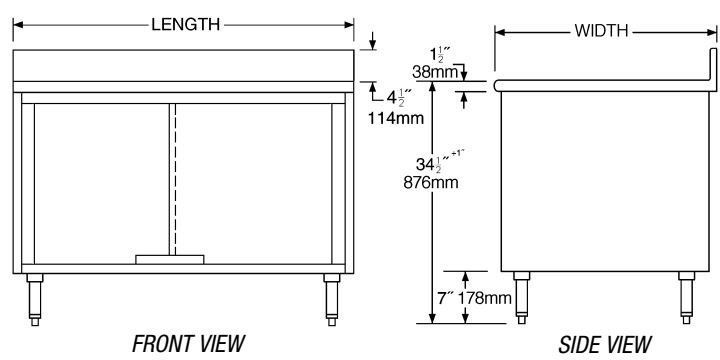

model #	width		length		weight		no. of legs
	in.	mm	in.	mm	lbs.	kg	
CB2436SE-BS	24"	610	36"	914	139	63.1	4
CB2448SE-BS	24"	610	48"	1219	171	77.6	4
CB2460SE-BS	24"	610	60"	1524	214	97.1	4
CB2472SE-BS	24"	610	72"	1829	256	116.1	4
CB2484SE-BS*	24"	610	84"	2134	304	137.9	6
CB2496SE-BS*	24"	610	96"	2438	343	155.6	6
CB24120SE-BS*	24"	610	120"	3048	390	176.9	6
CB3036SE-BS	30"	762	36"	914	143	64.9	4
CB3048SE-BS	30"	762	48"	1219	174	78.9	4
CB3060SE-BS	30"	762	60"	1524	221	100.2	4
CB3072SE-BS	30"	762	72"	1829	264	119.8	4
CB3084SE-BS*	30"	762	84"	2134	319	144.7	6
CB3096SE-BS*	30"	762	96"	2438	355	161.0	6
CB30120SE-BS*	30"	762	120"	3048	458	207.8	6

* Note: Worktables 84" (2134mm) and longer have two sets of doors.

Spec-Master® Enclosed Worktables with Hinged Doors

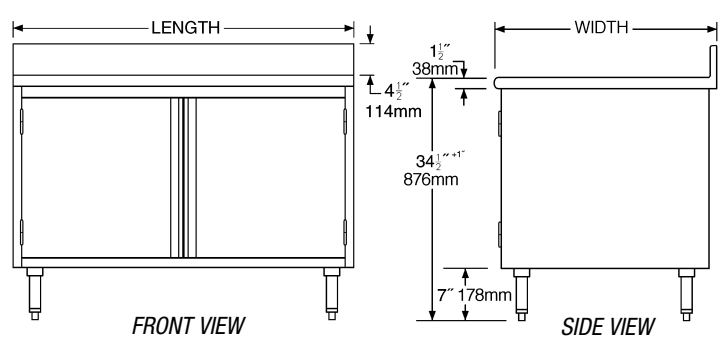

model #	width		length		weight		no. of legs
	in.	mm	in.	mm	lbs.	kg	
CBH2436SE-BS	24"	610	36"	914	139	63.1	4
CBH2448SE-BS	24"	610	48"	1219	171	77.6	4
CBH2460SE-BS	24"	610	60"	1524	214	97.1	4
CBH2472SE-BS	24"	610	72"	1829	256	116.1	4
CBH2484SE-BS*	24"	610	84"	2134	304	137.9	6
CBH2496SE-BS*	24"	610	96"	2438	343	155.6	6
CBH24120SE-BS*	24"	610	120"	3048	390	176.9	6
CBH3036SE-BS	30"	762	36"	914	143	64.9	4
CBH3048SE-BS	30"	762	48"	1219	174	78.9	4
CBH3060SE-BS	30"	762	60"	1524	221	100.2	4
CBH3072SE-BS	30"	762	72"	1829	264	119.8	4
CBH3084SE-BS*	30"	762	84"	2134	319	144.7	6
CBH3096SE-BS*	30"	762	96"	2438	355	161.0	6
CBH30120SE-BS*	30"	762	120"	3048	458	207.8	6

* Note: Worktables 84" (2134mm) and longer have two sets of doors.

EAGLE GROUP
 100 Industrial Boulevard, Clayton, DE 19938-8903 USA
 Phone: 302-653-3000 or 800-441-8440 • Fax: 302-653-2065
 www.eaglegrp.com • www.eaglehmc.com

Printed in U.S.A.
 ©2022 by Eagle Group
 Rev. 08/22

Spec sheets available for viewing, printing or downloading from our online literature library at www.eaglegrp.com

Although every attempt has been made to ensure the accuracy of the information provided, we cannot be held responsible for typographical or printing errors. Information and specifications are subject to change without notice. Please confirm at time of order.