

# SHURFLO® MEDIUM WATER BOOST SYSTEM

MAINTAINS CONSISTENT WATER PRESSURE FOR FOUNTAIN SYSTEMS

---

Medium Water Boost: 804-029  
Replacement Bladder: 94-697-00  
Replacement Pump: 8095-942-349



## APPLICATIONS

---

Fountain  
Coffee  
Drinking Water

## FEATURES • BENEFITS

---

Increases flow and pressure to carbonated and non-carbonated soda valves for consistent drink quality

Maximizes filter life on filtration systems

Replaceable bladder for maximum system life and simple maintenance

Self-priming pump can run dry without damage

Eliminates pulsation at dispenser valve resulting in more accurate brix ratio and maximum syrup utilization

Low profile allows for undercounter installation

Rigid stainless steel tanks

Complete turn-key package

Replaceable bladder

Quick connects

NSF® Certified

## INSTALLATION TIPS

---

Must be installed BEFORE the water filtration.

Charge tank precharge at time of installation is at 50 psi (3.45 bar).

Check precharge each service visit to ensure optimum performance.

Do not charge accumulator tank with CO<sub>2</sub>.

Use NSF listed high pressure braided tubing for inlet/outlet port (not included).

## OPERATION TIPS

---

## SIZING

---

Max. Working Pressure: 117 psi (8 bar).

Ports: 3/8" (10 mm) barb inlet/outlet

# SHURFLO® MEDIUM WATER BOOST SYSTEM

804-029

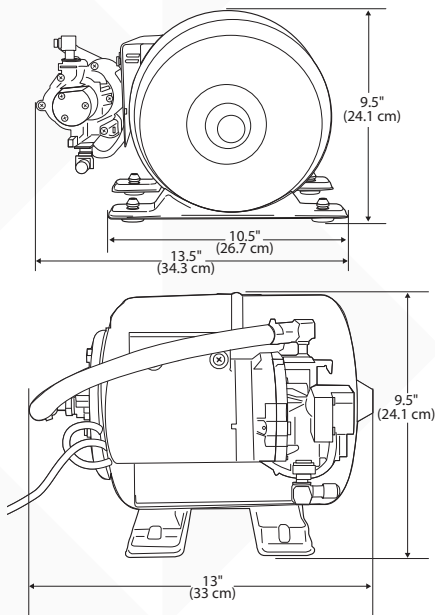

## SPECIFICATIONS

### Booster Pump

SHURflo 90 psi 230 VAC 8000 series non-corded pump (NSF, UL, CUL listed)

### Accumulator Tank

2 gallon (7.62 L) SS and butyl rubber bladder (NSF listed)

### Ports

3/8" (10 mm) barb inlet/outlet

### Pre-charge

W/air at installation

50 psi (3.4 bar) (recommended for most beverage applications)

### Draw Down Volume

0.75 gallon @ 50 psi (2.84 L @ 3.4 bar)

### Dimensions

13" H x 13" W x 10" D (33 x 33 x 25.4 cm)

### Electrical

230 Vac

### Max. Working Pressure

117 psi (8 bar)

### Temperature Limits

34 - 120°F (1.1 - 4.9°C)

### Weight

13 lbs (5.9 kgs) (empty)

2 Gallon Water Booster

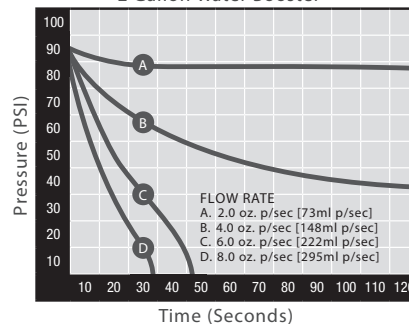

## WARRANTY

Limited Pentair® Warranty is valid from the date of manufacture or with proof of purchase:

- 2088 - One year
- Water Boost - One year
- Water Pressure Reducer Valve - One year
- 8000, 8025, 8010, 8075, 8095 - One year

Pentair will provide a copy of the warranty upon request.



## WATER FILTRATION

EVERPURE-SHURFLO WORLD HEADQUARTERS, 1040 MUIRFIELD DRIVE, HANOVER PARK, IL 60133 USA • FOODSERVICE.PENTAIR.COM  
800.942.1153 (US ONLY) • 630.307.3000 MAIN • 630.307.3030 FAX • CSEVERPURE@PENTAIR.COM EMAIL

EVERPURE-SHURFLO AUSTRALIA, 1-21 MONASH DRIVE, DANDENONG SOUTH, VIC 3175 AUSTRALIA  
011.1300 576 190 TEL • 011.61.39.562.7237 FAX • AU.EVERPURE@PENTAIR.COM EMAIL

EVERPURE-SHURFLO CHINA, 21F CLOUD 9 PLAZA, NO 1118, SHANGHAI, 200052, CHINA  
86.21.3211.4588 TEL • 86.21.3211.4580 FAX • CHINA.WATER@PENTAIR.COM EMAIL

EVERPURE-SHURFLO INDIA, GREEN BOULEVARD, B-9/A, 7TH FLOOR - TOWER B SECTOR 62, NOIDA - 201301  
91.120.419.9444 TEL • 91.120.419.9400 FAX • INDIACUSTOMER@PENTAIR.COM EMAIL

EVERPURE-SHURFLO EUROPE, PENTAIR WATER BELGIUM BVBA, INDUSTRIEPARK WOLFSTEE, TOEKOMSTLAAN 30, B-2200 HERENTALS, BELGIUM  
+32.(0).14.283.504 TEL • +32.(0).14.283.505 FAX • SALES@EVERPURE-EUROPE.COM EMAIL

EVERPURE-SHURFLO JAPAN INC., HASHIMOTO MN BLDG. 7F, 3-25-1 HASHIMOTO, MIDORI-KU, SAGAMIHARA-SHI KANAGAWA 252-0143, JAPAN  
81.(0)42.775.3011 TEL • 81.(0)42.775.3015 FAX • INFO@EVERPURE.CO.JP EMAIL

EVERPURE-SHURFLO SOUTHEAST ASIA, 390 HAVELOCK ROAD, #04-01 KING'S CENTRE, SINGAPORE 169662  
65.6768.5800 TEL • 65.6737.5149 FAX • CSEVERPURE@PENTAIR.COM EMAIL

Pentair trademarks and logos are owned by Pentair plc or its affiliates. Third party registered and unregistered trademarks and logos are property of their respective owners. Because we are continuously improving our products and services, Pentair reserves the right to change specifications without prior notice. Pentair is an equal opportunity employer.