



Cook & Chill Process line composed of:

UCPMDG1-48L - Automatic cooker (C&C line version)

Constructive Features

- cooking vessel in stainless steel AISI 316 (thickness 30/10). Perforated basket in stainless steel AISI 316 (thickness 15/10) with electric tilting
- balanced lid in stainless steel AISI 304 (thickness 10/10)
- supporting structure in stainless steel AISI 304 (thickness 20-30/10)
- heat insulation guaranteed by panels in thick glass fibre
- outer cover in stainless steel AISI 304, fine satin finish (thickness 10/10)
- adjustable feet in stainless steel AISI 304 to ensure levelling
- protection level IPX4

Functional Features General

- heating by means of high efficiency stainless steel tube burners. Automatic ignition and flame control system without pilot burner. Heating controlled by electronic board with automatic activation of minimum 2 °C before the SETPOINT and interruption of heating in case of minimum water level. Baskets lifting and tilting automatically (even with closed lid) stopping in dripping position and removable for cleaning operations. Automatic filling and refilling of water in the vat. Overflow device and front drain cock in stainless-steel, 2 inc., with insulating handle. Optional: removable shower head (cold water) to make cleaning operations easier. Electronic control by means of multifunctional keyboard with Touch Screen 7" and easy and clear messages
- electric socket for connection to UBAVRDX.. / UBAVRSX.. (do not use for other purpose)
- USB connection to download HACCP data, update the software and load cooking programs
- ability to interrogate the machine using communication protocol MODBUS over RS485 serial interface

Panel Board Functions

- ON/OFF switch
- resistive 7" touch screen
- keys for moving basket
- selection of 2 different cooking modes , with working temperature setting or min./max. heating
- cooking type and time setting
- cooking in "Manual" mode
- cooking in "Program" mode
- creating and editing cooking programs, setting: type of cooking; cooking parameters (temperature and time), and possibility to insert text messages
- automatic vat filling with level maintenance
- function starch skimming
- delayed cooking setting with date, time, and programming cycle
- language settings touch Screen
- input of different units of measurement (° C/° F; Liters/gallons; etc)

Display/Signal

- display type of cooking, temperature probes used and set temperature
- heating operating visual alarm
- time to end of cycle display
- water level insufficient (heating does not activate)
- signalling and blocking heat in case there is no gas
- gas control unit "RESET" message
- basket lifting (end of cooking) visual alarm with 10 seconds notice by lighter on the Touch screen
- self-diagnostics

Safety System

- emergency button
- heating interruption due to insufficient amount of water in vat

UBAVR48DX - Mobile chilling vat

Constructive Features

- chilling tank in AISI 316
- perforated basket in stainless steel AISI 316 (thickness 15/10) and removable for cleaning operations
- supporting structure in stainless steel AISI 304 (thickness 20-30/10)
- external panels in AISI 304 fine satin finish
- pivoting wheels, 2 with brakes

Functional Features General

- lifting up and down of the basket inside the cooling tank with electric tilting
- forced water activation by means of of dedicated pump, operating only with baskets in working position and valve regulation flow
- filling and recirculation of water in the vat by ball valve
- overflow device and discharge valve in stainless-steel, 2 inc., with insulating handle

Panel Board Functions

- ON/OFF switch
- basket tilting and return
- ON/OFF switch agitation pump
- flow agitation regulation

Safety System

- thermal protection for agitation pump (light alarm)

Optionals

- UCAD0020 - CLEANING SHOWER FOR UCPM..

Accessories

- NOT PRESENT

Certificates



Planner

.....

.....

.....

.....

.....

.....

.....

.....

.....

.....

UBACC1010 - Insulated trolley

Constructive Features

- entirely made of AISI 304 stainless steel
- insulated basins, pressed with rayed edges and with a drain equipped with ball wash-out valve
- dimensions suitable for GN 1/1 h.200 containers
- shaped lower shelf
- rubber buffers
- 4 pivoting wheels, 2 of them with brakes

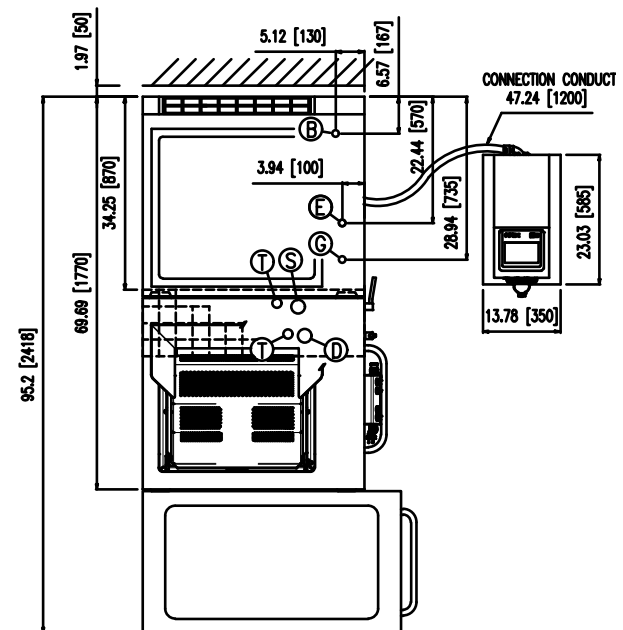
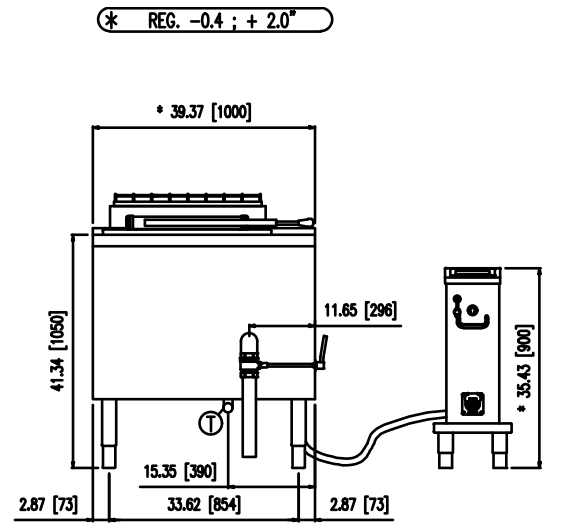
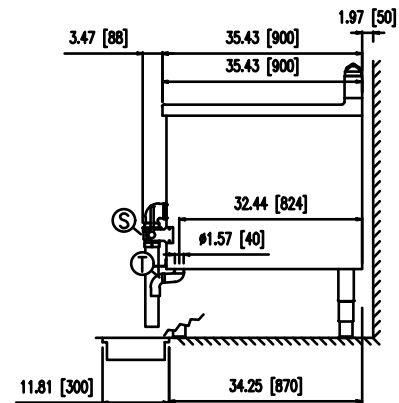
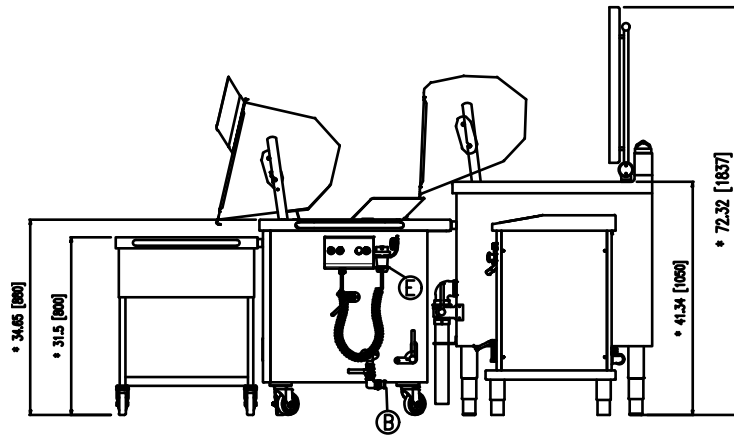

* REG. -0.4 ; + 2.0°

UCPMDG1-48L - Technical specifications

Dimensions weights and capacities

Width	39 3/8 inch	Vessel width	27 9/16 inch	Overall capacity	48 gal
Depth	35 3/8 inch	Vessel depth	25 1/4 inch	Number of baskets	1
Height	41 3/8 inch	Vessel height	16 1/2 inch	Weight	485 lb

Water connection

H2O drain (S)	2 inch	Cold water inlet (B)	1/2 inch	Overflow (T)	3/8 inch
Water pressure	25±50 PSI				

Gas connection

Gas connection (G)	3/4"	Gas power	121,500 BTU/h		
--------------------	------	-----------	---------------	--	--

Electrical connection

STD Voltage (E)	2 PHASE 220-240V ~ 60Hz	Electric power	2.30 kW	Current	10.0 A
OPT Voltage (E)	2 PHASE 208V ~ 60Hz	Electric power	2.30 kW	Current	10.5 A

UBAVR48DX - Technical specifications

Dimensions weights and capacities

Width	39 3/8 inch	Vessel width	27 9/16 inch	Overall capacity	48 gal
Depth	35 3/8 inch	Vessel depth	25 1/4 inch	Number of baskets	1
Height	38 5/8 inch	Vessel height	16 1/2 inch	Weight	386 lb

Water connection

H2O drain (S)	2 inch	Cold water inlet (B)	3/4 inch	Overflow (T)	1 5/8 inch
Water pressure	25±50 PSI				

Electrical connection

STD Voltage (E) *	1 PHASE 230V ~ 60Hz	Electric power	1.45 kW	Current	--- A
-------------------	---------------------	----------------	---------	---------	-------

* connected to multicooker, not to main supply

UBACC1010 - Technical specifications

Dimensions weights and capacities

Width	49 3/8 inch	Vessel width	37 3/8 inch	Overall capacity	3 GN1/1
Depth	25 1/4 inch	Vessel depth	20 1/8 inch	Weight	112 lb
Height	31 1/2 inch	Vessel height	8 5/8 w inch		