

SR-X FEEDER/DELIMING SYSTEM

SUPERIOR SCALE PREVENTION AND CORROSION CONTROL FOR STEAM EQUIPMENT

SR-X Feeder and Deliming System: EV9797-20
SS-10 Replacement Cartridge: EV9799-02



APPLICATIONS

- ◆ Scale Reduction Applications
- ◆ Scale Reduction For Steam Applications
- ◆ Deliming Capabilities

FEATURES • BENEFITS

- ◆ A complete system that effectively targets scale
- ◆ Patented design dispenses a controlled amount of Hydroblend™ for long-term protection and provides greater effectiveness than standard phosphate treatments
- ◆ A sophisticated blend of polyphosphate compound represents an advancement in scale inhibition
- ◆ Provides protection against equipment corrosion
- ◆ System includes clear Pentair® Everpure® SR-X housing, Pentair Everpure SS-10 cartridge, dip tube assembly, and a 2.2 lb Pentair Everpure ScaleKleen package
- ◆ The SS-10 is NSF® Certified under NSF/ANSI Standard 42 for material requirements only
- ◆ SS-10 cartridge is more effective in higher alkalinity/hardness/TDS/temperature installations

INSTALLATION TIPS

- ◆ Choose a mounting location suitable to support the full weight of the system when operating.
- ◆ Make sure to properly lubricate o-ring prior to use.
- ◆ Use 3/4" water line (optional reducer bushings included).
- ◆ Install vertically with bowl hanging down.
- ◆ Allow 2 1/2" (6.35 cm) clearance below the cartridge for easy cartridge replacement.
- ◆ For steam applications, connect the system to the boiler water only. Do not connect to the condenser.

OPERATION TIPS

- ◆ Deliming of equipment prior to application is recommended, but not required.
- ◆ Inspect SS-10 cartridge at least every six (6) months.
- ◆ Replace SS-10 cartridge before Hydroblend™ compound is completely dissolved.
- ◆ Pre-existing equipment scale may come loose and clog equipment. Remove any loose scale to assure satisfactory operation.

SIZING

- ◆ Service Flow Rate:
Maximum 6.0 gpm (22.7 Lpm)

SR-X FEEDER/DELIMING SYSTEM

EV9797-20

SR-X Feeder and Deliming System: EV9797-20
SS-10 Replacement Cartridge: EV9799-02

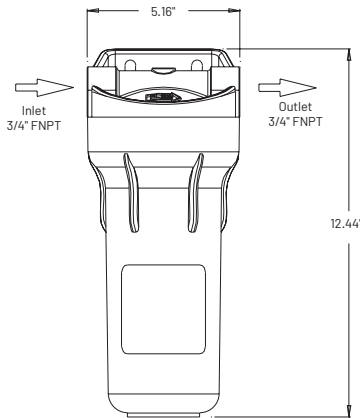

SPECIFICATIONS

- ◆ **Service Flow Rate**
Maximum 6.0 gpm (22.7 Lpm)
- ◆ **Pressure Requirements**
10 - 125 psi (0.7 - 8.6 bar), non-shock
- ◆ **Temperature**
35 - 100°F (2 - 38°C)
- ◆ **Overall Dimensions**
12.44" L x 5.16" W x 5.5" D
(31.5 cm x 13.1 cm x 13.9 cm)
- ◆ **Inlet Connection** 3/4"
- ◆ **Outlet Connection** 3/4"
- ◆ **Operating Weight**
6 lbs (2.7 kgs)
- ◆ **Shipping Weight**
6 lbs (2.7 kgs)
- ◆ **Electrical Connection**
None required



WARRANTY

Everpure water treatment systems by Pentair (excluding replaceable elements) are covered by a limited warranty against defects in material and workmanship for a period of five years after date of purchase. Everpure replaceable elements (filter cartridges and water treatment cartridges) are covered by a limited warranty against defects in material and workmanship for a period of one year after date of purchase. See printed warranty for details. Pentair will provide a copy of the warranty upon request.

The contaminants or other substances removed or reduced by this drinking water system are not necessarily in your water. Do not use with water that is microbiologically unsafe or of unknown quality without adequate disinfection before or after the system.

Since the conditions under which our products may be used are beyond our control, we cannot accept any liability with respect to the improper installation, application and/or use of our products.



World Headquarters
1040 Muirfield Drive
Hanover Park, IL 60133
United States
800.942.1153 (US Only)
630.307.3000 Main
cseverpure@pentair.com

Europe
Pentair Water Belgium BVBA
Industriepark Wolfstee,
Toekomstlaan 30,
B-2200 Herentals
Belgium
+32.(0)14.283.504 Tel
sales@everpure-europe.com

Australia
1-21 Monash Drive
Dandenong South, Vic 3175
Australia
011.1300 576 190 Tel
au.everpure@pentair.com

Japan Inc.
Hashimoto MN Bldg. 7F,
3-25-1 Hashimoto, Midori-ku,
Sagamihara-shi
Kanagawa 252-0143
Japan
81.(0)42.775.3011 Tel
info@everpure.co.jp

China
21F Cloud 9 Plaza, NO 1118
Shanghai, 200052
China
86.21.3211.4588 Tel
china.water@pentair.com

Southeast Asia
390 Havelock Road,
#04-01 King's Centre
Singapore 169662
65.6768.5800 Tel
cseverpure@pentair.com

India
Boulevard, B-9/A,
7th Floor - Tower B Sector 62
Noida - 201301
91.120.419.9444 Tel
indiacustomer@pentair.com

§ Pentair trademarks and logos are owned by Pentair plc or its affiliates. For a detailed list of where Pentair trademarks are registered, please visit www.pentair.com/en/registrations.html. Third party registered and unregistered trademarks and logos are the property of their respective owners. Because we are continuously improving our products and services, Pentair reserves the right to change specifications without prior notice. Pentair is an equal opportunity employer.