



ELECTRICAL CONTROLS - SWITCHES

MANUAL SWITCH – MS

- Push button ON/OFF switch
- High impact polycarbonate construction
- NEMA 4 - water tight enclosure
- Single direction only
- Magnetic starter/provides automatic shut-off in case of power interruption
- Operates on line voltage



MANUAL REVERSE SWITCH – MRS

- 3 - Button switch with FWD/STOP/REV
- Stainless steel construction
- NEMA 4 - water tight enclosure
- Manual reverse allows increased cutting element life and reduces jams
- Magnetic starter/provides automatic shut-off in case of power interruption
- Operates on line voltage
- CUL approved switch



LOW VOLTAGE SWITCH – MSLV

- Push button ON/OFF switch
- Stainless steel construction
- NEMA 4 water tight enclosure
- Single direction only
- Line disconnect on front panel
- Magnetic starter/provides automatic shut-off in case of power interruption
- Low voltage (24 volt) control circuit



ENCLOSURE DIMENSIONS ON REVERSE SIDE

A complete collection of our product drawings is available for download at the **InSinkErator Revit/CAD Library**, which can be found at www.insinkerator.com/foodservice. Product information is also accessible on **The KCL CADalog**. More information is available from KCL at www.kclcad.com.



1250 International Drive
Mount Pleasant, WI 53177
TEL: 800-845-8345

www.insinkerator.com/foodservice



ENCLOSURE DIMENSIONS (Inches)

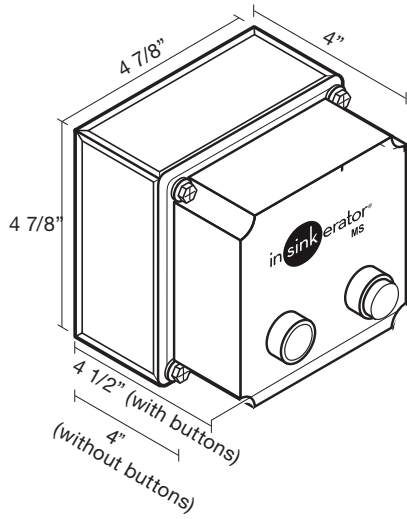

MANUAL SWITCH - MS

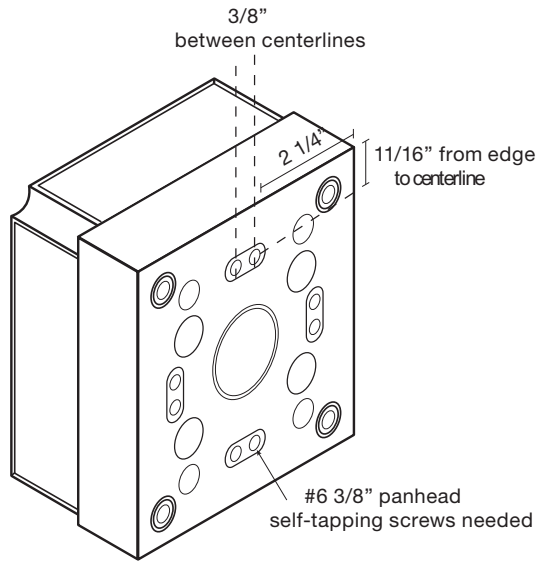

MANUAL REVERSE SWITCH - MRS

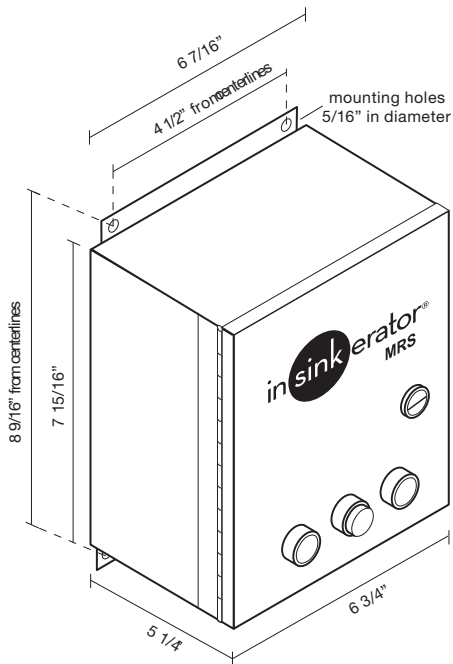

LOW VOLTAGE SWITCH - MSLV

