

"CP" HARDWOOD CONVENIENCE BENCHES

Maple Slats w/Black Enamel Base - Interior Use Only

FEATURES:

- Splinter Free Maple Slats With A Sturdy Steel Base
- Slat Size: 2-1/4"x1-1/4"
- Black Enamel Steel Base With Rubber Feet
- Clear Tuff-Var Finish
- For Interior Use Only



CPB48-M

"CP" HARDWOOD CONVENIENCE BENCHES

MODEL	SIZE (L X W X H)	WT. (LBS)
CPB48-M	48"x21"x33"	71
CPB60-M	60"x21"x33"	80
CPB72-M	72"x21"x33"	91
CPB96-M	96"x21"x33"	140

ALL DIMENSIONS ARE TYPICAL. TOLERANCE +/- .500". JOHN BOOS & CO. RESERVES THE RIGHT TO CHANGE SPECIFICATIONS WITHOUT NOTICE.

DETAILED SPECIFICATIONS

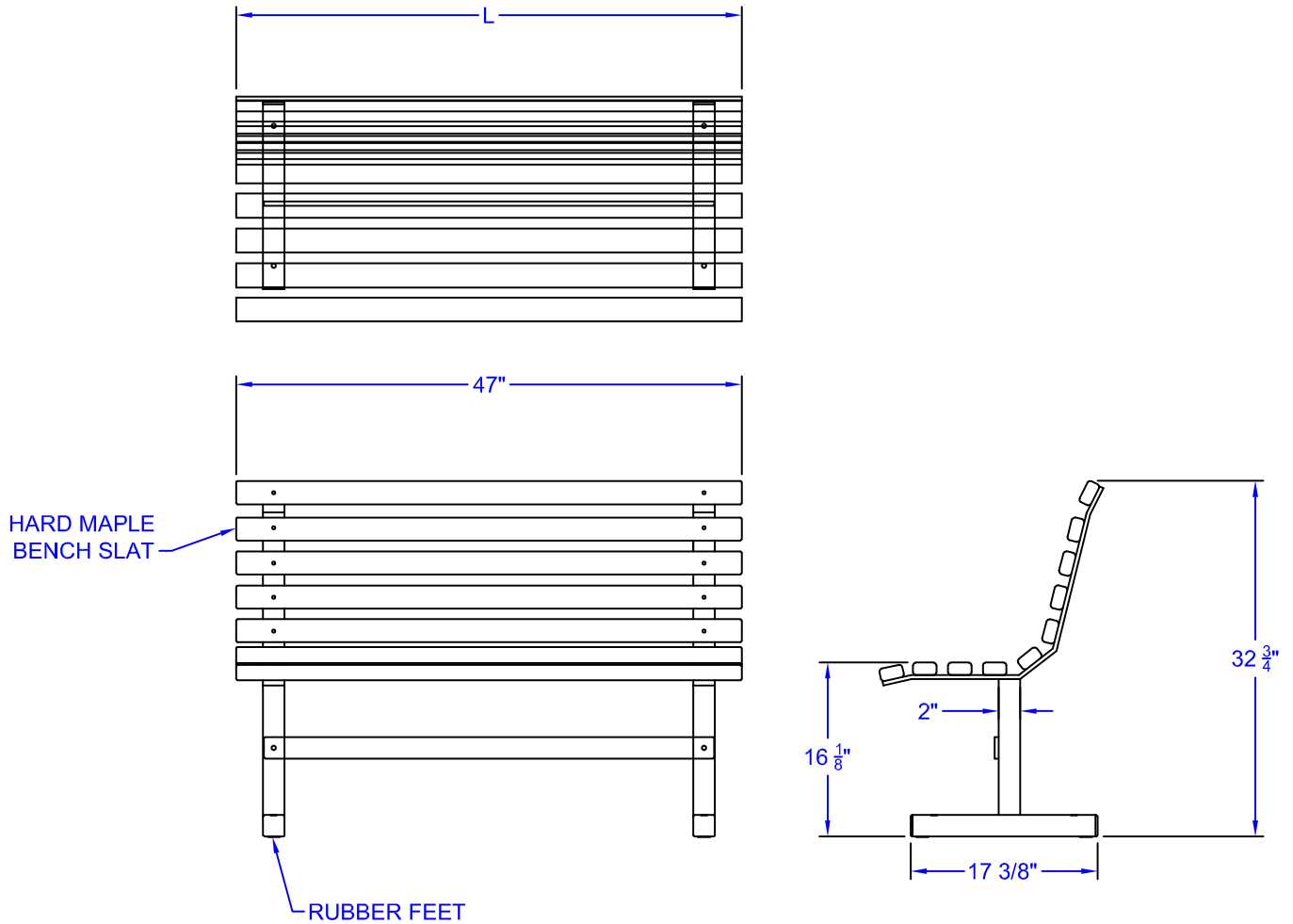

"CP" HARDWOOD CONVENIENCE BENCHES

MODEL	SIZE (L X W X H)	WT. (LBS)
CPB48-M	48"x21"x33"	71
CPB60-M	60"x21"x33"	80
CPB72-M	72"x21"x33"	91
CPB96-M	96"x21"x33"	140

ALL DIMENSIONS ARE TYPICAL. TOLERANCE +/- .500". JOHN BOOS & CO. RESERVES THE RIGHT TO CHANGE SPECIFICATIONS WITHOUT NOTICE.