

50Hz

# iP0500 Ice Cube Machine

## Models

IDP0500A  IYP0500A



R290



Indigo NXT Series iP0500 Ice Machine on D570 Bin  
\*Ice machine and bin sold separately

Designed for operators who know that ice is critical to their business, the Indigo NXT Series ice machine's preventative diagnostics continually monitor itself for reliable ice production. Improvements in cleanability and programmability make your ice machine easy to own and less expensive to operate.

- **R290 Natural Refrigerant** - Minimize global warming potential and still maintain high performance with R290 Propane Refrigerant.
- **easyTouch® Display** - New icon based touch screen takes the guess work out of owning and operating an ice machine.
- **Multiple Language Capability** - The easyTouch display is available in multiple languages selected in the initial start-up installation Wizard.
- **Programmable Ice Production** - Now its super easy to program your ice machine to be off at certain times of the day to save money with fluctuating electrical rates. Also programmable by daily ice production volume and night time programming.
- **Easy to Clean Foodzone** - Hinge front door swing out for easy access. Removable water-trough, distribution tube, curtain, water probe and water pump for fast and efficient cleaning. Selected components are made with AlphaSan® antimicrobial.
- **Intelligent Diagnostics** - Provides 24 hour preventative maintenance and diagnostic feedback for trouble free operation.
- **Acoustical Ice Sensing Probe** - Unique patented technology allows for reliable operation in challenging water conditions and environments
- Available **LuminIce® II Virus and Bacteria Inhibitor** - Controls viruses, bacteria mold and yeast within the food zone to keep the ice machine clean longer. A new sanitation icon lets you know the operational status.
- **Active Sense** - insures consistent ice harvest in all environmental conditions. This software works in conjunction with the acoustical ice sensing probe improving reliability and performance.

## Ice Machine Electric

230/50/1

### Minimum circuit ampacity:

Air-cooled: 5.6

### Maximum fuse size:

Air Cooled: 15 amps

## Specifications

### BTU Per Hour:

3,800 (average),  
and 6,000 (peak)

### Refrigerant:

R290 CFS Free.  
Non- ozone depleting  
and near zero GWP

### Operating Limits:

- Ambient Temperature Range:  
40° to 110° F (4.4° to 43.3° C)  
Water Temperature Range:  
40° to 90° F (4.4° to 32.2° C)
- Water Pressure Ice Maker  
Water In:  
Min. 20 psi (137.9 kPa)  
Max. 80 psi (551.1 kPa)



## Ice Shape



**Half Dice**  
3/8" x 1 1/8" x 7/8"  
(.95 x 2.86 x 2.22 cm)  
Cube weight 5.7 g



**Dice**  
7/8" x 7/8" x 7/8"  
(2.22 x 2.22 x 2.22 cm)  
Cube weight 8.5 g



Indigo® NXT™ iP0500 Ice Cube Machine



## iP0500 on D-570 Storage Bin

- Ⓐ Electrical Entrance (2) Options
- Ⓑ 3/8" (0.95 cm) F.P.T. Water Condenser Inlet (water-cooled units)
- Ⓒ 1/2" (1.27 cm) F.P.T. Water Condenser Outlet (water-cooled units)
- Ⓓ 1/2" (1.27 cm) Auxillary Base Drain Socket
- Ⓔ 3/8" (0.95 cm) F.P.T. Ice Making Water Inlet
- Ⓕ 1/2" (1.27 cm) F.P.T. Ice Making Water Drain
- Ⓖ 3/4" (1.91 cm) Bin Drain

**Installation Note**  
Minimum installation clearance:

Top/side: 12" (30.50 cm)  
Back is 5" (12.7 cm)

**Shipping Weight**  
72 kg  
159 lbs

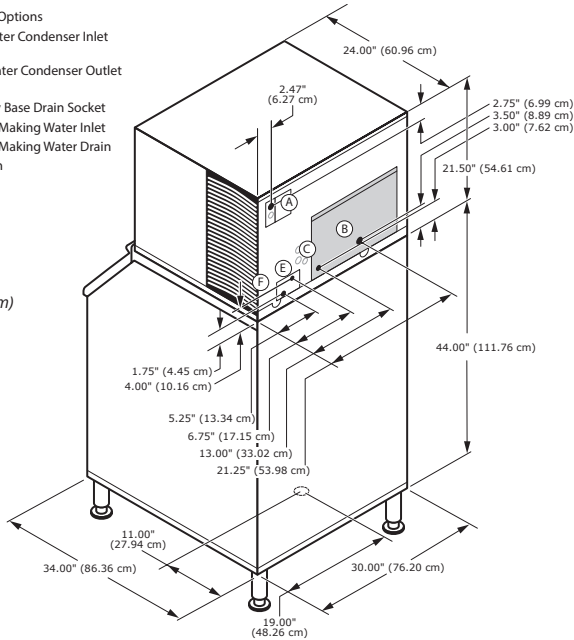

## Space-Saving Design



	iP0500 D-400	iP0500 D-570
Height	59.50"	71.50"
Width	151.13 cm	181.61 cm
Depth	30.00"	30.00"
Bin	365 lbs.	532 lbs.
Storage	165.7 kgs.	241.1 kgs.

Height includes adjustable bin legs 6.00" to 8.00", (15.24 to 20.32 cm) set at 6.00" (15.24 cm).  
Bin capacity is based on 90% of the volume x 33 lbs/ft<sup>3</sup> average density of ice.  
(Ice machine and bin sold separately)

## Specifications

	Model	Ice Shape	Ice Production 24 Hours		Power Usage kWh 45.4 kg / 100 lbs @ 32°Air / 21°C Water 90°Air / 70°F Water	Potable Water Usage/100 lbs. 45.4 kgs. of Ice
			21°Air / 10°C Water 70°Air / 50°F Water	32°Air / 21°C Water 90°Air / 70°F Water		
<b>AIR COOLED</b>	IDP0500A	dice	420 lbs.	345 lbs.	1 Ph	19 Gal.
			191 kgs	156 kgs		71.9 L
	IYP0500A	half-dice	440 lbs.	360 lbs.	5.06	19 Gal.
			200 kgs	163 kgs		71.9 L

R290 is a refrigerant grade propane, which is naturally occurring with no ozone depletion potential and extremely low global warming potential

## Accessories

**LuminIce® II Virus and Bacteria Inhibitor**  
controls viruses and bacteria in the ice machine.



**External Scoop holder**  
protect the ice scoop with the NSF approved versatile scoop holder.



**Arctic Pure® Plus Water Filters**  
reduce sediments and chlorine contaminants down to .5 microns. Use with a Pre-filter is recommended.



Welbilt reserves the right to make changes to the design or specifications without prior notice.

Welbilt Deutschland GmbH  
Auf der Weih 11  
D - 35745 Herborn, Germany  
Tel.: +49 27 72 58 050  
welbilt.com.de

Welbilt Iberia, S.A.U  
Textil, 6 - Pol.Ind. La Ferreria - 08110  
Montcada i Reixac  
Barcelona, Spain  
Tel.: +34 902 20 10 69  
welbilt.com.es

Welbilt UK  
Ashbourne House The Guildford,  
Old Portsmouth Rd Guildford GU3  
1LR United Kingdom  
Tel.: +44 1483 464900  
www.welbilt.uk

